

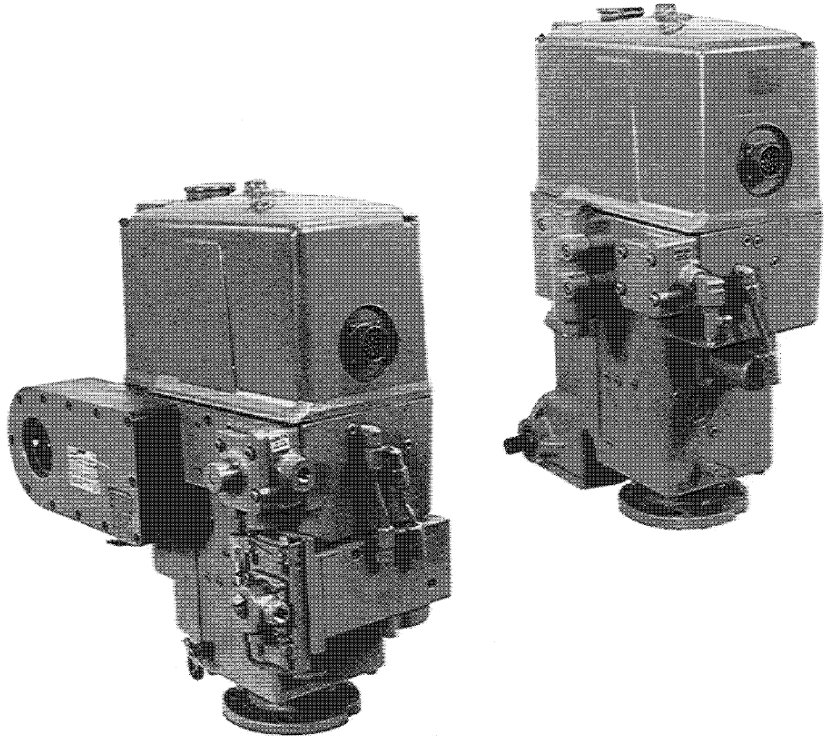

## Installation and Operation Manual



## PGEV and PGE Locomotive Governors

Manual 36703



## WARNINGS

**FOLLOW INSTRUCTIONS**—Read this entire manual and all other publications pertaining to the work to be performed before installing, operating, or servicing this equipment. Practice all plant and safety instructions and precautions. Failure to follow instructions can cause personal injury and/or property damage.



**OUT-OF-DATE PUBLICATION**—This publication may have been revised or updated since this copy was produced. To verify that you have the latest revision, be sure to check the Woodward website:

[www.woodward.com/pubs/current.pdf](http://www.woodward.com/pubs/current.pdf)

The revision level is shown at the bottom of the front cover after the publication number. The latest version of most publications is available at:

[www.woodward.com/publications](http://www.woodward.com/publications)

If your publication is not there, please contact your customer service representative to get the latest copy.



**OVERSPEED PROTECTION**—The engine, turbine, or other type of prime mover should be equipped with an overspeed shutdown device to protect against runaway or damage to the prime mover with possible personal injury, loss of life, or property damage.

The overspeed shutdown device must be totally independent of the prime mover control system. An overtemperature or overpressure shutdown device may also be needed for safety, as appropriate.



## CAUTIONS

**BATTERY CHARGING**—To prevent damage to a control system that uses an alternator or battery-charging device, make sure the charging device is turned off before disconnecting the battery from the system.



**ELECTROSTATIC DISCHARGE**—Electronic controls contain static-sensitive parts. Observe the following precautions to prevent damage to these parts.

- Discharge body static before handling the control (with power to the control turned off, contact a grounded surface and maintain contact while handling the control).
- Avoid all plastic, vinyl, and Styrofoam (except antistatic versions) around printed circuit boards.
- Do not touch the components or conductors on a printed circuit board with your hands or with conductive devices.



## IMPORTANT DEFINITIONS

**WARNING**—indicates a potentially hazardous situation which, if not avoided, could result in death or serious injury.



**CAUTION**—indicates a potentially hazardous situation which, if not avoided, could result in damage to equipment.



**NOTE**—provides other helpful information that does not fall under the warning or caution categories.

Woodward Governor Company reserves the right to update any portion of this publication at any time. Information provided by Woodward Governor Company is believed to be correct and reliable. However, no responsibility is assumed by Woodward Governor Company unless otherwise expressly undertaken.

© Woodward 1990  
All Rights Reserved

# Contents

<b>CHAPTER 1. GENERAL INFORMATION.....</b>	<b>1</b>
Introduction.....	1
Specifications .....	1
<b>CHAPTER 2. INSTALLATION AND ADJUSTMENT .....</b>	<b>11</b>
Introduction.....	11
Installation .....	11
Adjustments.....	12
Oils For Hydraulic Controls .....	13
<b>CHAPTER 3. PRINCIPLES OF OPERATION .....</b>	<b>16</b>
Introduction.....	16
Basic Governing Section .....	16
Speed Setting Section.....	19
Load Control Section.....	22
Fuel Limiter.....	31
Load Control Override Linkage .....	35
Start Fuel Limiter .....	36
<b>CHAPTER 4. TROUBLESHOOTING.....</b>	<b>38</b>
Introduction.....	38
Oil .....	38
Compensating Needle Valve.....	38
Definitions.....	38
Preliminary Inspection .....	39
<b>CHAPTER 5. MAINTENANCE .....</b>	<b>43</b>
Introduction.....	43
Special Tools .....	43
General Instructions .....	43
Disassembly .....	43
Repair or Replacement .....	59
Cleaning .....	59
Lubrication .....	59
Assembly .....	59
<b>CHAPTER 6. TEST AND ADJUSTMENT.....</b>	<b>86</b>
Test Setup .....	86
<b>CHAPTER 7. REPLACEMENT PARTS .....</b>	<b>90</b>
<b>CHAPTER 8. SERVICE OPTIONS .....</b>	<b>118</b>
Product Service Options.....	118
Returning Equipment for Repair.....	119
Replacement Parts.....	120
How to Contact Woodward.....	120
Engineering Services .....	121
Technical Assistance.....	122
<b>APPENDIX. AUXILIARY EQUIPMENT .....</b>	<b>123</b>

## Illustrations and Tables

Figure 1-1. Left Front View of PGE Governor (Remote Vane Servo Apps).....	2
Figure 1-2. Right Rear View of PGE Governor (Remote Vane Servo Apps).....	2
Figure 1-3. Left Front View of PGEV Governor (Integral Vane Servo Apps).....	3
Figure 1-4. Right Rear View of PGEV Governor (Integral Vane Servo Apps).....	3
Figure 1-5a. Outline Drawing of PGE Governor with Rotary Servo.....	4
Figure 1-5b. Outline Drawing of PGE Governor with Rotary Servo.....	5
Figure 1-6a. Outline Drawing of PGEV Governor with Integral Vane Servo and Rotary Output.....	6
Figure 1-6b. Outline Drawing of PGEV Governor with Integral Vane Servo and Rotary Output.....	7
Figure 1-7a. Outline Drawing of PGEV Governor with Integral Vane Servo, Water Box, and Linear Output.....	8
Figure 1-7b. Outline Drawing of PGEV Governor with Integral Vane Servo, Water Box, and Linear Output.....	9
Figure 1-8. Typical Wiring Diagram.....	9
Figure 1-9. Typical Wiring Diagram for 12 Pole Connector.....	10
Figure 1-10. Typical Wiring Diagram for 16 Pole Connector.....	10
Figure 2-1. Viscosity Comparison Chart.....	15
Figure 2-2. Oil Comparison Chart.....	15
Figure 3-1. Schematic Diagram of Typical PGEV Governor.....	21
Figure 3-2. Sectional Diagram PGE Governor.....	23
Figure 3-3a. Integral Vane Servo (with Resistor Pack Assembly).....	28
Figure 3-3b. Integral Vane Servo (with Ceramic Resistor).....	28
Figure 3-4. Lube Oil Pressure Shutdown and Alarm.....	30
Figure 3-5. Typical Limited Acceleration Fuel Schedule Curve.....	31
Figure 3-6a. Schematic Diagram, Fuel Limiter and Linkage.....	33
Figure 3-6b. Start Fuel Limiter Linkage.....	37
Figure 5-1. PGEV with Fuel Limiter.....	44
Figure 5-2. Solenoid Pack.....	44
Figure 5-3. Fuel Limiter Installed.....	45
Figure 5-4. Fuel Limiter Assembly.....	45
Figure 5-5. Overriding Solenoid Spring and Piston.....	45
Figure 5-6. Load Control Bushing, Spring, and Gasket.....	45
Figure 5-7. Triangular Plate and Speed Setting Cylinder Installed on Column.....	46
Figure 5-8. Speed Setting Cylinder and Triangular Plate.....	46
Figure 5-9. Time Delay Mechanism Installed.....	47
Figure 5-10. Time Delay Mechanism and Speed Setting Pilot Valve Assembly.....	47
Figure 5-11. Bypass Valve.....	47
Figure 5-12. Vane Servo.....	48
Figure 5-13. Vane Servo and Oil Filter.....	48
Figure 5-14. Low Lube Oil Cover and Diaphragm.....	49
Figure 5-15. Side Plate.....	50
Figure 5-16. Low Lube Oil and Timing Valve Systems.....	50
Figure 5-17. Power Case and Power Servo.....	50
Figure 5-18. Compensation System.....	51
Figure 5-19. Drive Shaft.....	51
Figure 5-20. Power Case and Base.....	52
Figure 5-21. Ballhead Assembly.....	52
Figure 5-22. Power Case.....	53
Figure 5-23. Solenoid Pack and Receiver.....	53
Figure 5-24. Solenoid and Receiver Assembly.....	54
Figure 5-25. Speed Setting Cylinder.....	54
Figure 5-26. Fuel Limit Bracket and Linkage.....	55
Figure 5-27. Fuel Limiter Sensor and Bellows.....	56

## Illustrations and Tables

Figure 5-28. Fuel Limiter Orifice.....	57
Figure 5-29. Speed Setting Servo.....	58
Figure 5-30. PVP Adjustment.....	60
Figure 5-31. PVP Adjustment Procedure.....	61
Figure 5-32. Assembly of Power Servos.....	62
Figure 5-33. Power Case.....	63
Figure 5-34. Drive Shaft and Base.....	64
Figure 5-35. Compensation System.....	64
Figure 5-36. Power Case Assembly Complete.....	65
Figure 5-37. Column to Power Case Assembly.....	65
Figure 5-38. Timing Valve.....	66
Figure 5-39. Lube Oil Shutdown.....	66
Figure 5-39A. Differential Area Lube Oil Shutdown.....	67
Figure 5-40. Load Control Supply Valve.....	67
Figure 5-41. Vane Assembly.....	68
Figure 5-42. Side Plate.....	69
Figure 5-43. Wires Threaded into Column.....	69
Figure 5-44. Side Plate Mounting Holes.....	69
Figure 5-45. Resistor Pack and Side Plate Assembly.....	70
Figure 5-46. Contact Plate Assembly.....	71
Figure 5-47. Side Plate Cover.....	71
Figure 5-48. Oil Filter.....	72
Figure 5-49. Lube Oil Shutdown Cap.....	73
Figure 5-50. Bypass Valve.....	73
Figure 5-51. Load Control Bushing.....	74
Figure 5-52. Load Control Pilot Valve Assembly.....	75
Figure 5-53. Spring Seat Tool.....	75
Figure 5-54. Speed Setting Valve.....	76
Figure 5-55. Speed Setting Servo.....	77
Figure 5-56. Speed Setting and Triangular Plate.....	78
Figure 5-57. Fuel Limiter Orifice.....	79
Figure 5-58. Fuel Limiter Sensor and Bellows.....	80
Figure 5-59. Linkage Arrangement.....	80
Figure 5-60. Fuel Limit Bracket and Linkage.....	81
Figure 5-61. ORS Bracket.....	82
Figure 5-62. Fuel Limiter and Load Control Assembly.....	82
Figure 5-63. Floating Lever Connection.....	83
Figure 5-64. Lever and Linkage with Overriding Solenoid.....	83
Figure 5-65. Lever and Linkage.....	84
Figure 5-66. Water Box.....	85
Figure 6-1. PGEV Test (Right-hand Side).....	86
Figure 6-2. PGEV Test (Front).....	87
Figure 6-3. PGEV Test (Left-hand Side).....	87
Figure 6-4. Speed Setting Assembly.....	88
Figure 6-5. Solenoid Pack.....	88
Figure 6-6. PGEV.....	89
Figure 7-1. Exploded View of PGEV Governor Assembly (8571-882 Type).....	91
Figure 7-2. Exploded View of PGEV Governor Assembly (8571-561 Type).....	93
Figure 7-3. Exploded View of Power Case and Pilot Valve Assembly.....	95
Figure 7-4. Exploded View of Standard Base.....	96
Figure 7-5. Exploded View of Linear Power Servo.....	97
Figure 7-6. Exploded View of Rotary Power Servo.....	99
Figure 7-7. Exploded View of Differential Area Lube Oil Shutdown.....	100
Figure 7-8. Exploded View of Low Lube Oil Shutdown.....	101

## Illustrations and Tables

Figure 7-9. Exploded View of Time Delay and Bypass Valve .....	102
Figure 7-10. Exploded View of Load Control Pilot Valve Assembly.....	103
Figure 7-11. Exploded View of Vane Servo (Resistor Pack) .....	105
Figure 7-12. Exploded View of Vane Servo (Ceramic Resistor) .....	107
Figure 7-13. Exploded View of Speed Setting Servo .....	109
Figure 7-14. Exploded View of Fuel Limiter .....	111
Figure 7-15. Exploded View of Oil Filter.....	112
Figure 7-16. Exploded View of Electrical Receiver Assembly .....	115
Figure 7-17. Exploded View of Water Box .....	117
Table 4-1. Troubleshooting .....	40

# Chapter 1.

## General Information

### Introduction

The PGE governor is basically a standard PG hydraulic governor to regulate engine speed with a number of special adaptations for locomotive and train operation. It includes an electro-hydraulic speed setting mechanism for remote control of engine speed, a mechanical-hydraulic load control device for automatic regulation of engine load to maintain a specific power output at each speed setting, and a 12 ft-lb (16 J) single acting spring return hydraulic power servo with tailrod. The power servo may have either a reciprocating (linear) or rotary output. The governors may be arranged for use with a remote vane servomotor to adjust the generator exciter rheostat or they may include both servomotor and rheostat as integral parts of the governor. See Figures 1-1 through 1-4.

The manuals listed below supplement the information contained in this manual and are required to provide complete coverage:

- 36600, *PG Governor Basic Elements*
- 36692, *PG Power Cylinder Assemblies*
- 36693, *PG Base Assemblies*

A number of optional auxiliary features and devices are available for use, either singly or in combination with the PGE and PGEV governors. These devices permit the governor to perform other secondary functions in addition to its primary function of regulating engine speed and power output. A list of manuals of these features and devices follows:

- 36404, *Type PG Governors Analysis and Correction of Governing Troubles*
- 36405, *Recommended Tools for PG Governors*
- 36601, *Absolute Manifold Pressure Bias Load Control and Fuel Limiter*
- 36652, *Automatic Safety Shutdowns and Alarms*
- 36695, *Manifold Air Pressure Bias Fuel Limiter (inline Model)*

### Specifications

Mounting Base and Drive:	See Figures 1-5, 1-6, 1-7
Mounting Attitude:	Vertical
Drive Rotation:	Fixed cw, fixed ccw, or reversible
Maximum Speed Range:	200 to 1600 rpm
Recommended Speed Range:	200 to 1200 rpm
Drive Power Requirement:	1/2 hp (373 W) at maximum drive speed and normal hydraulic viscosity
Hydraulic Fluid:	Petroleum base lubricating oil (contact Woodward if other hydraulic fluids are to be used)
Recommended Viscosity Range:	100 to 200 SSU (minimum of 50 to a maximum of 3000 SSU for wide range applications). See manual 25071, <i>Oils for Hydraulic Controls</i>
Supply:	Self-contained, 1-5/8 quart (1.5 L) capacity (approx.). Two quart (1.9 L) capacity with integral vane servo.
Pressure:	Approximately 100 psi (690 kPa)
Normal Operating Temperature:	-20 to +210 °F (-29 to +99 °C). Contact Woodward beyond these limits. Hydraulic fluid pour point must be below lowest expected starting temperature.

**Output Specifications**

Useful Work Capacity:	8.0 ft-lb (10.8 J)
Maximum Work Capacity:	12.0 ft-lb (16.3 J)
Stroke (Reciprocating Output):	1.0 inch (25.4 mm)
Angular Travel (Rotary Output):	30 degrees
Terminal Shaft (Rotary Output):	3/4 inch (19.05 mm) diameter, 48 serrations
Weight:	105 to 130 lb (48 to 59 kg) depending on optional features

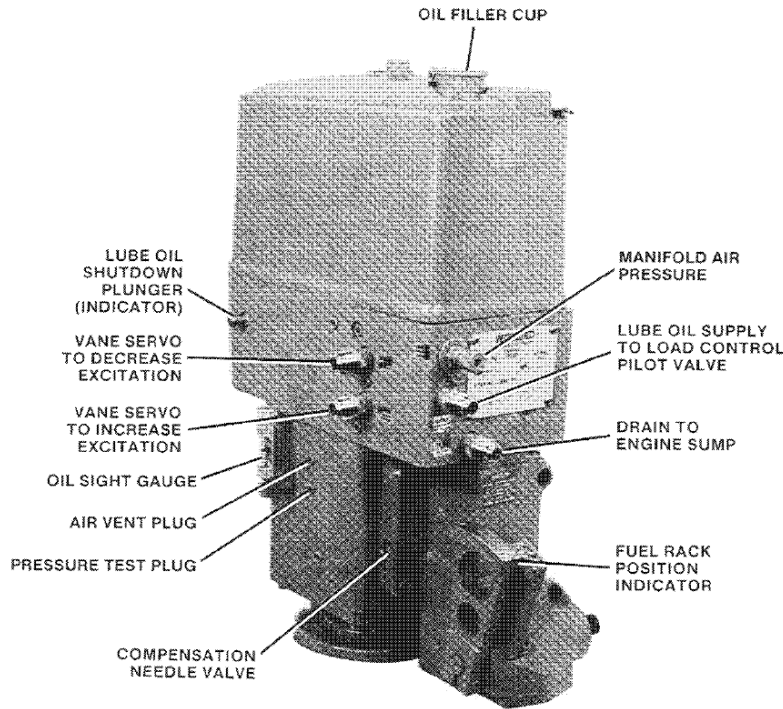

Figure 1-1. Left Front View of PGE Governor (Remote Vane Servo Apps)

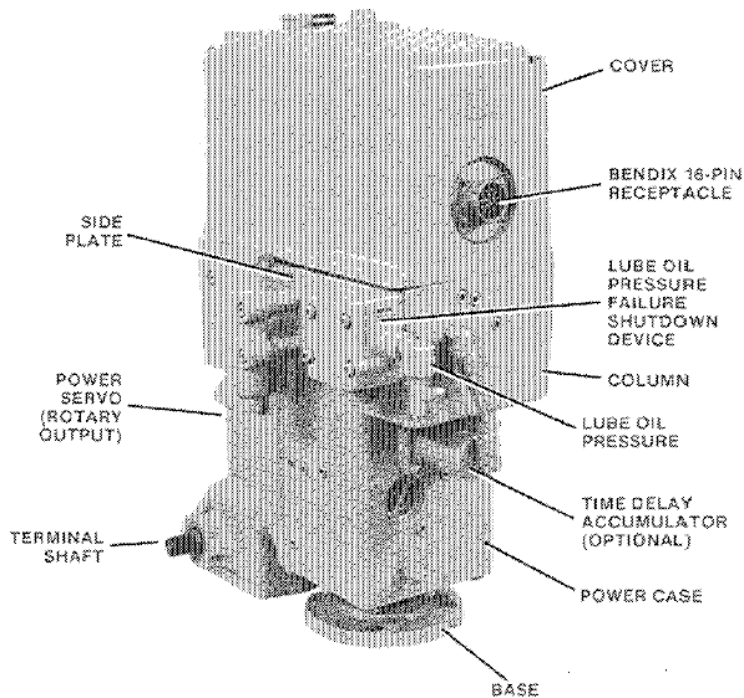

Figure 1-2. Right Rear View of PGE Governor (Remote Vane Servo Apps)

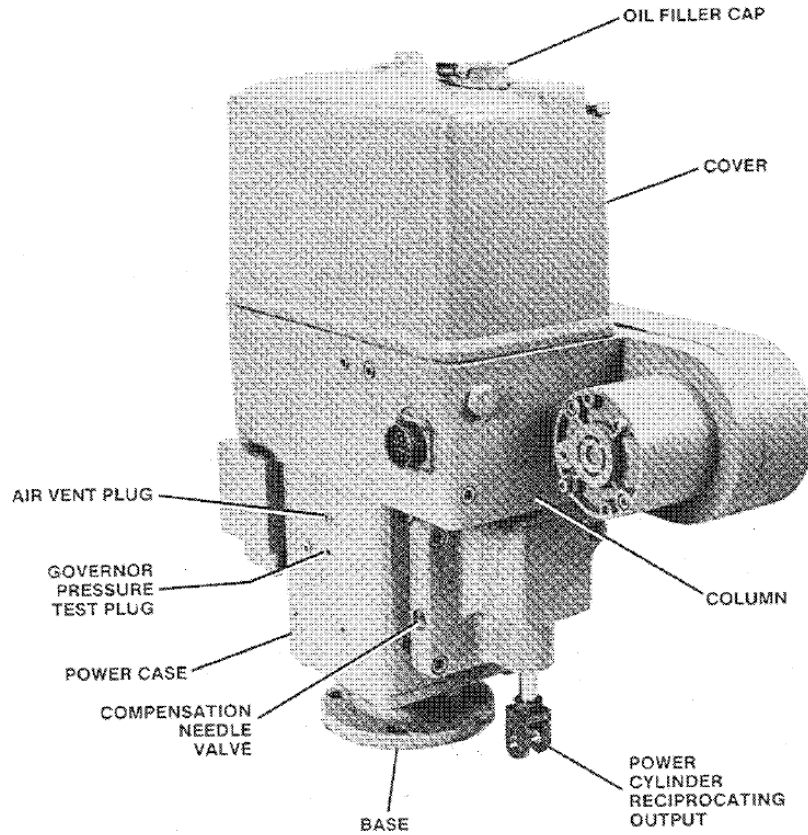

Figure 1-3. Left Front View of PGEV Governor (Integral Vane Servo Apps)

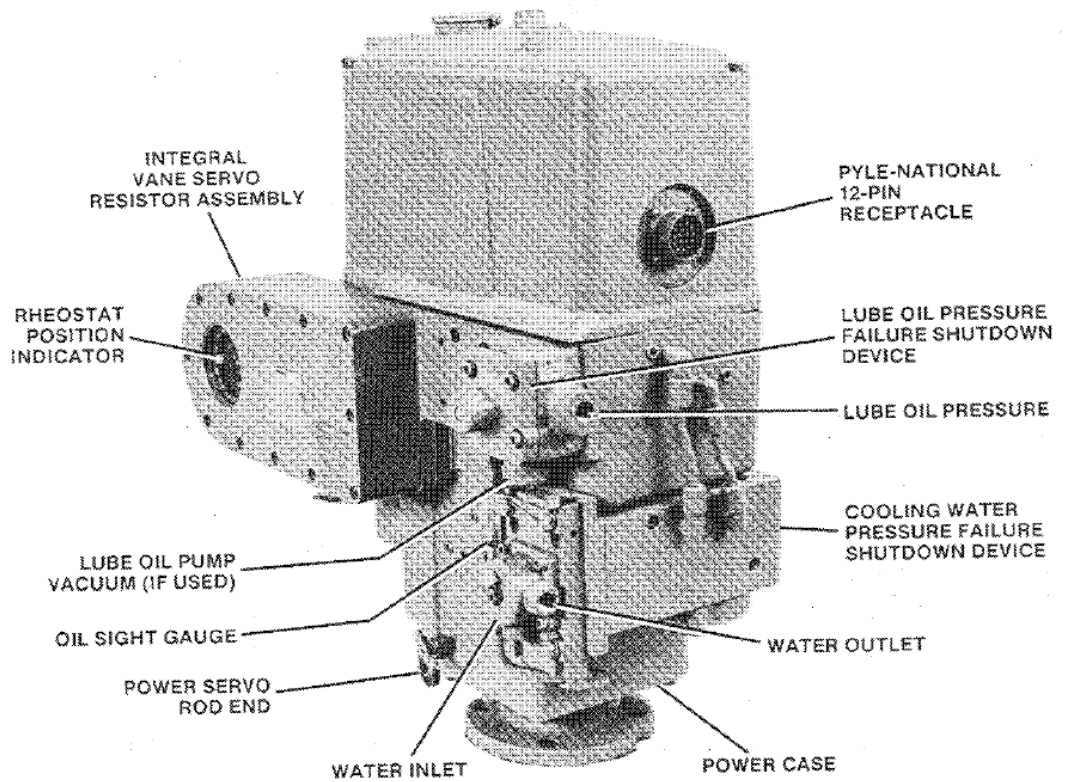

Figure 1-4. Right Rear View of PGEV Governor (Integral Vane Servo Apps)

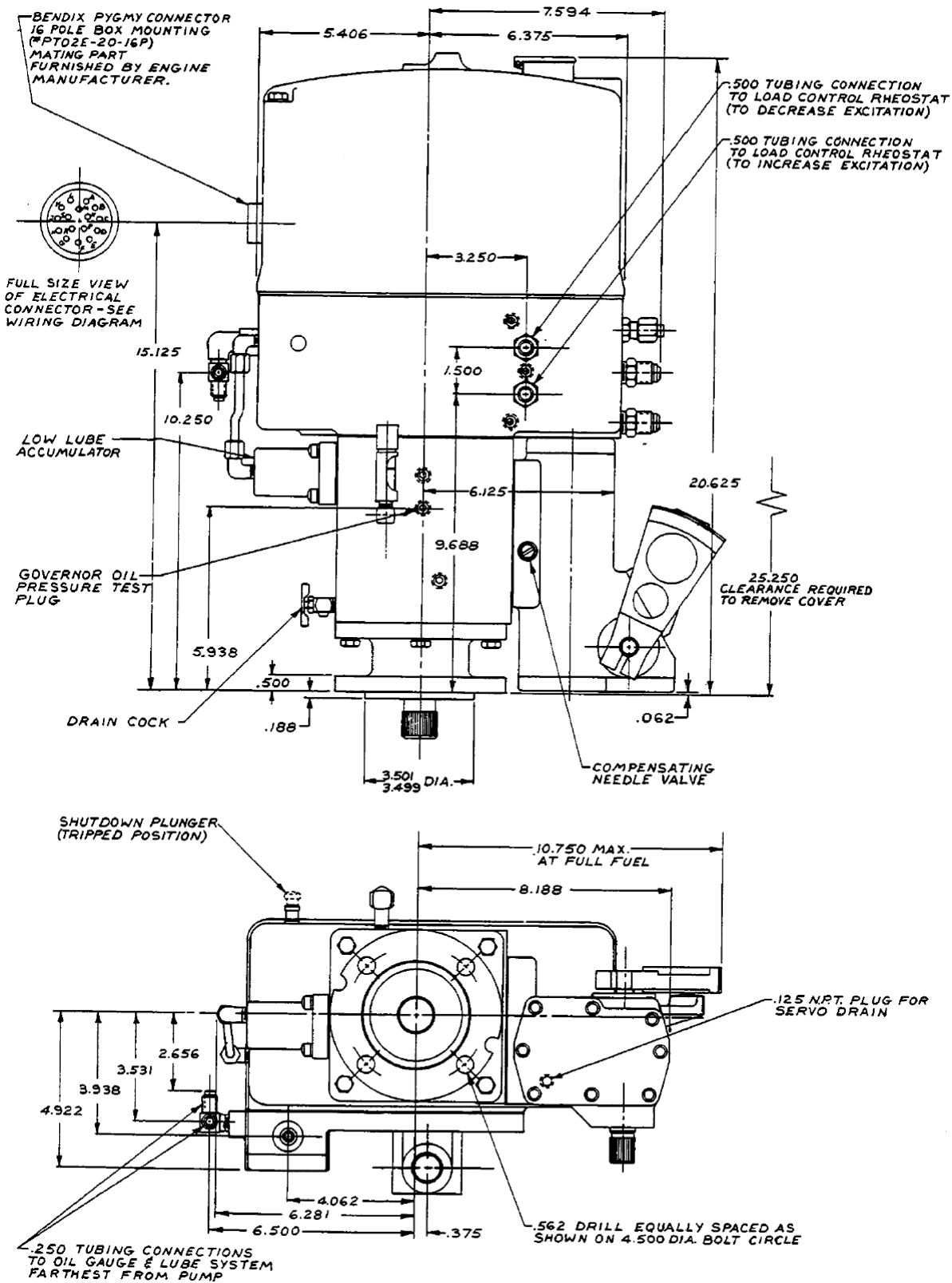

Figure 1-5a. Outline Drawing of PGE Governor with Rotary Servo

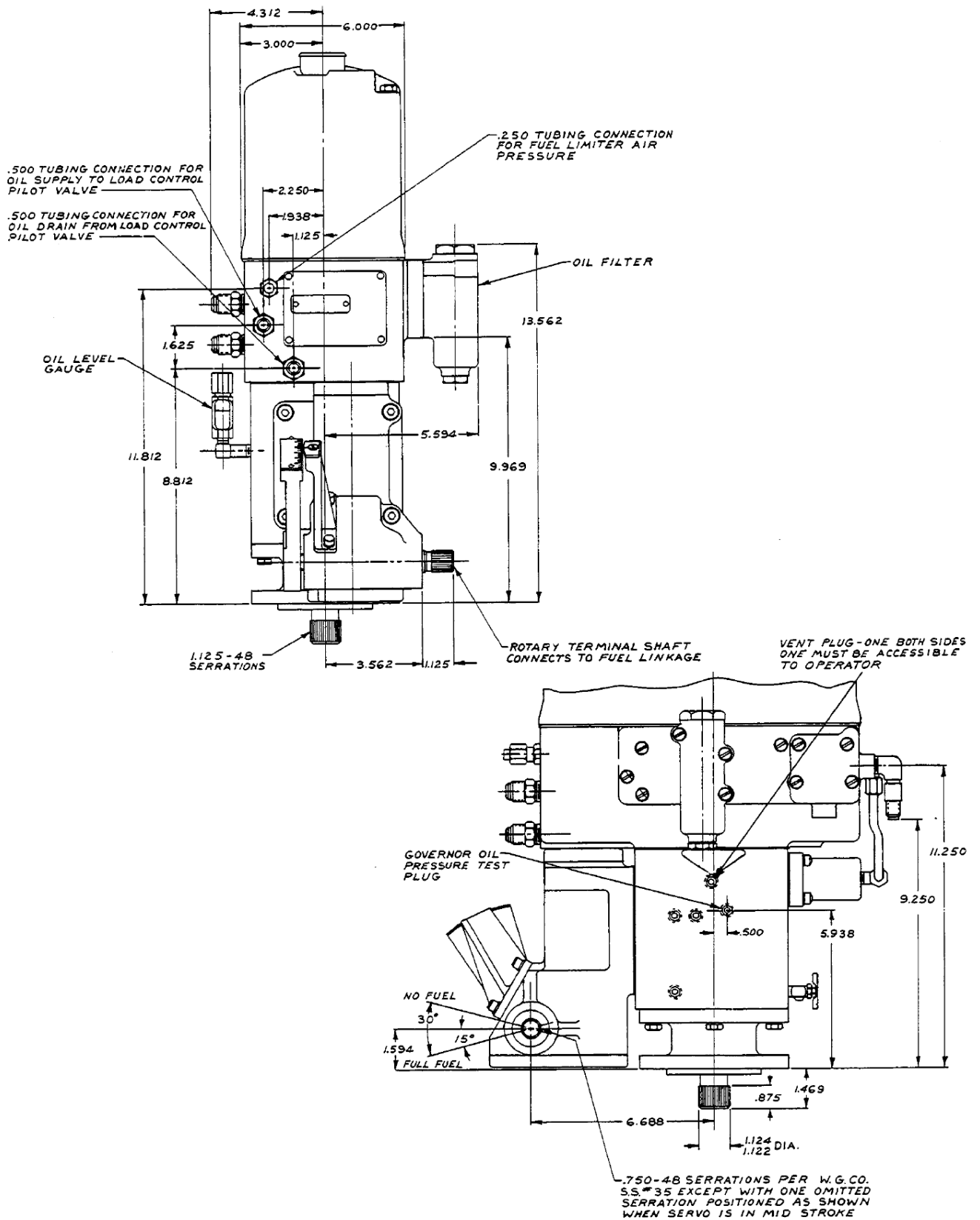

Figure 1-5b. Outline Drawing of PGE Governor with Rotary Servo

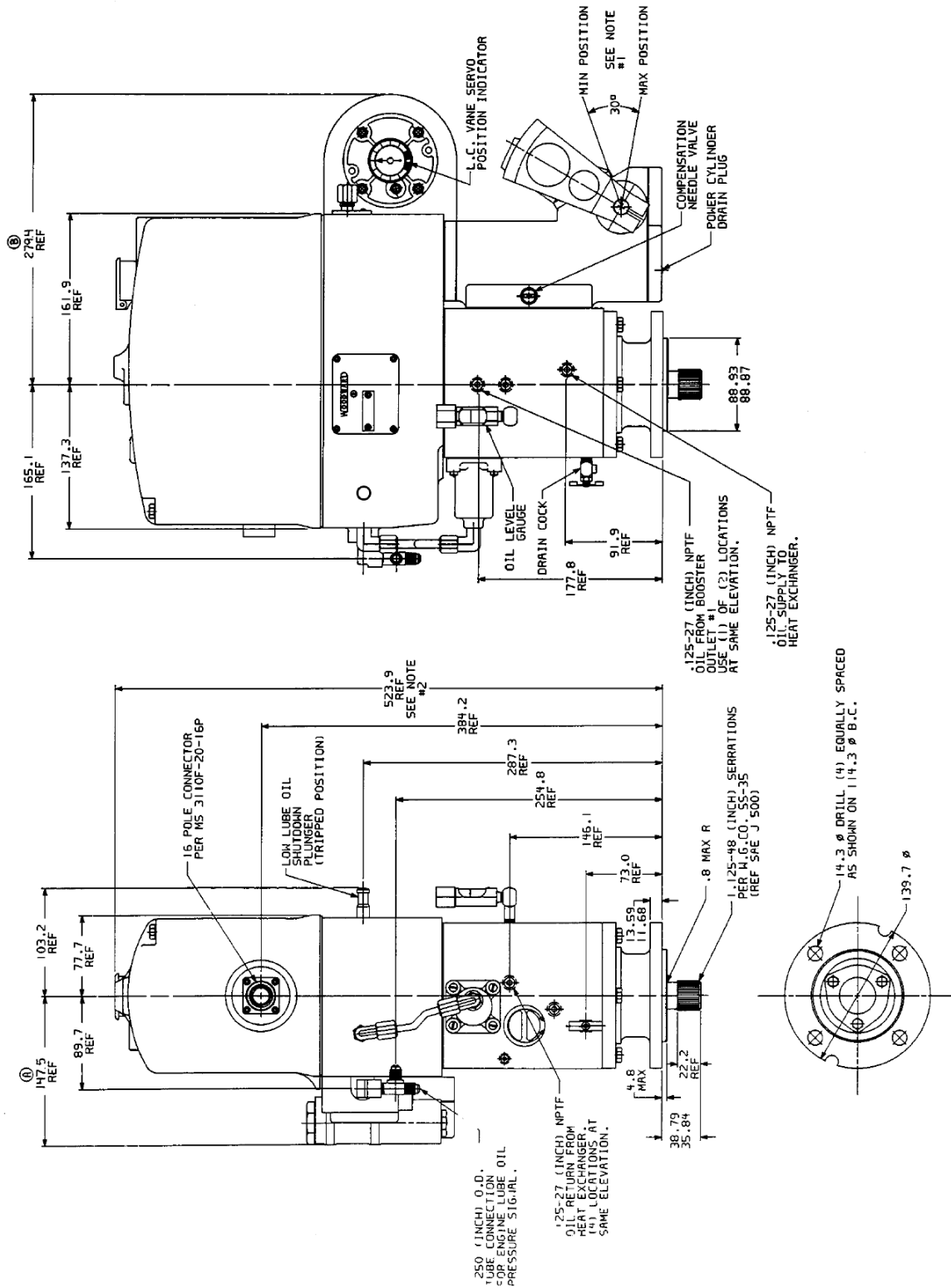
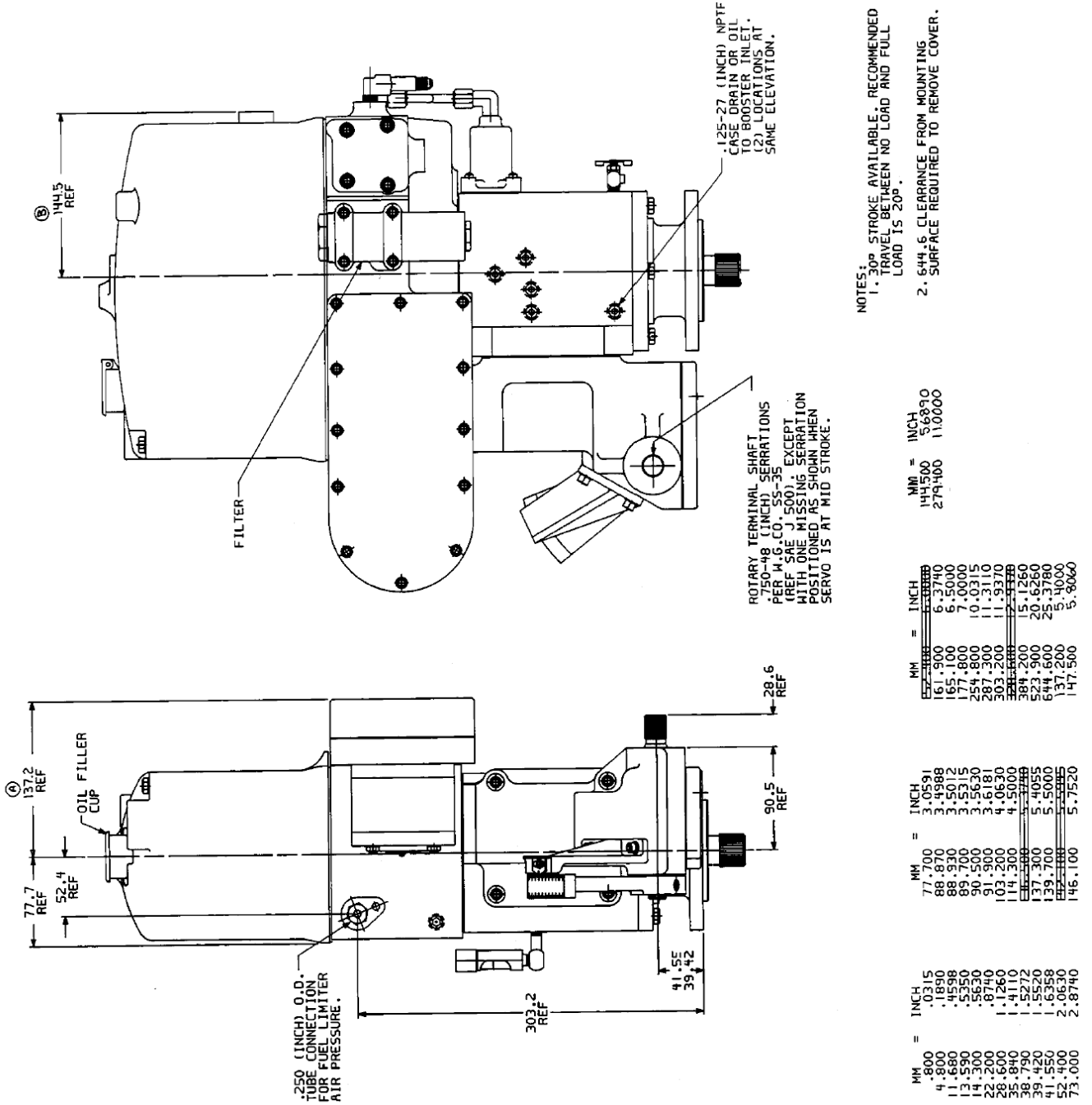

Figure 1-6a. Outline Drawing of PGEV Governor with Integral Vane Servo and Rotary Output  
(Do not Use for Construction)



NOTES:  
 1. 30° STROKE AVAILABLE. RECOMMENDED TRAVEL BETWEEN NO LOAD AND FULL LOAD IS 20°.  
 2. 5/4" ± CLEARANCE FROM MOUNTING SURFACE REQUIRED TO REMOVE COVER.

Figure 1-6b. Outline Drawing of PGEV Governor with Integral Vane Servo and Rotary Output  
 (Do not Use for Construction)

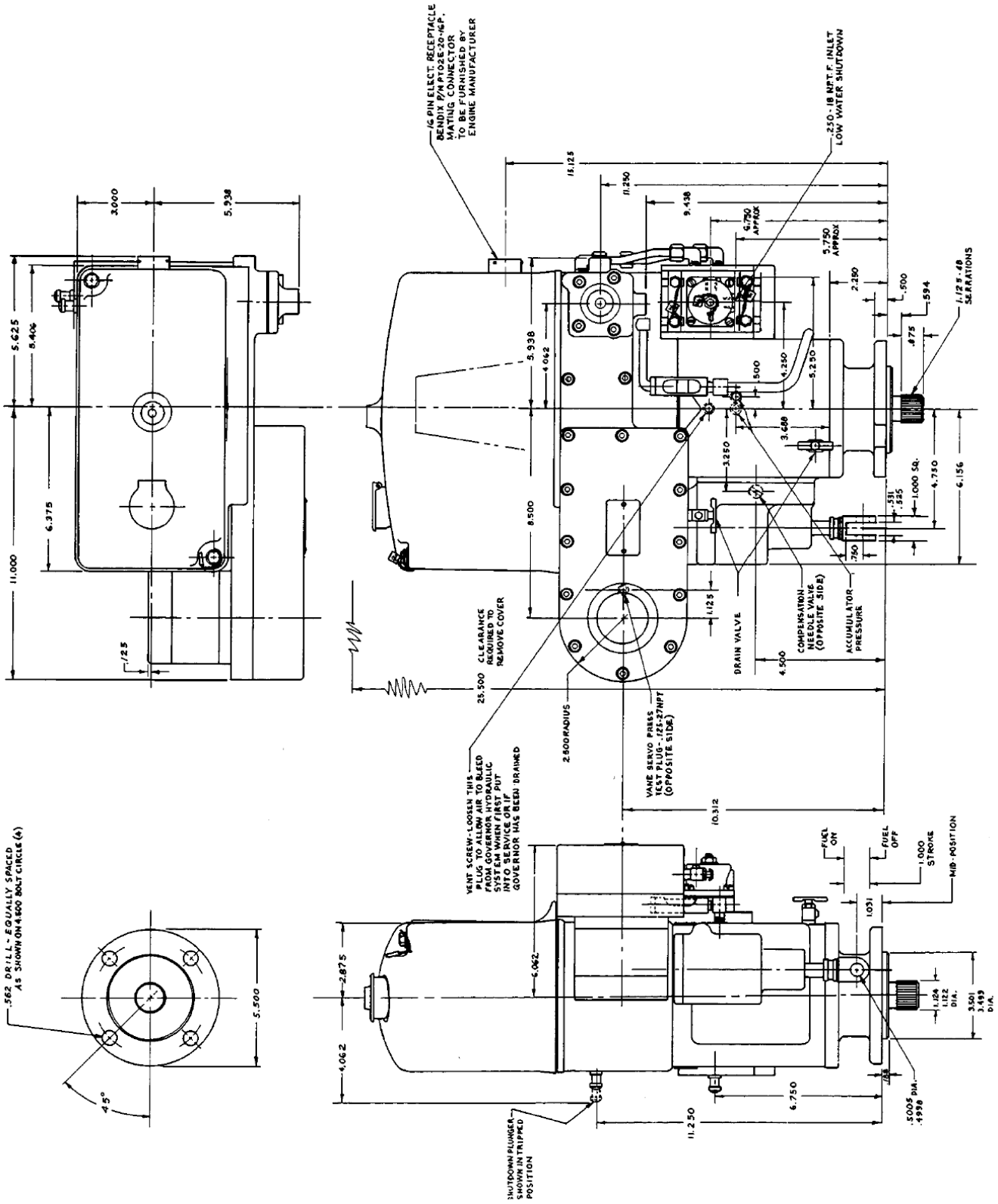

Figure 1-7a. Outline Drawing of PGEV Governor with Integral Vane Servo, Water Box, and Linear Output (Do not Use for Construction)

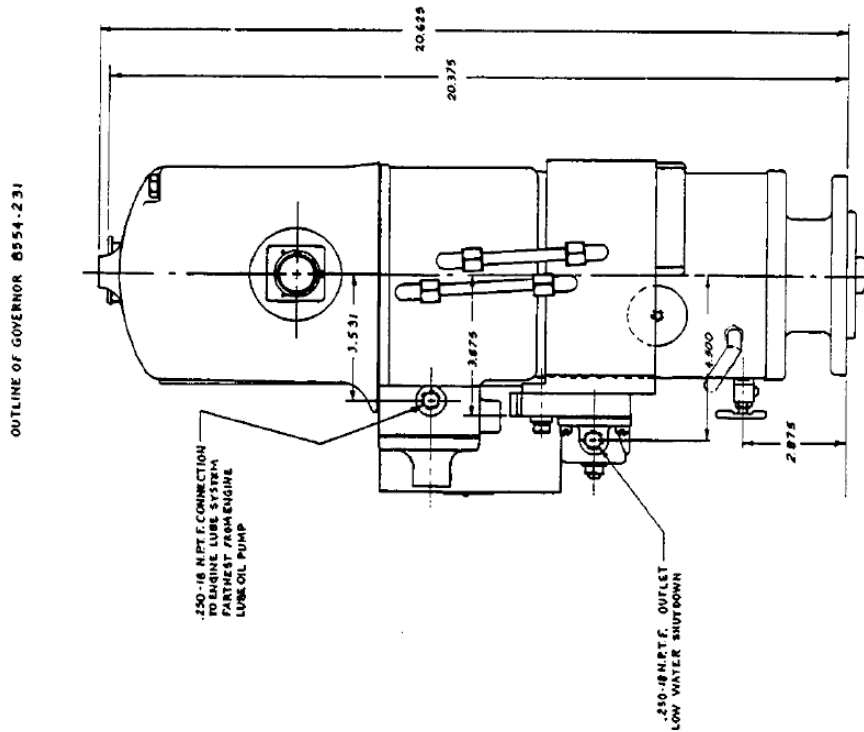
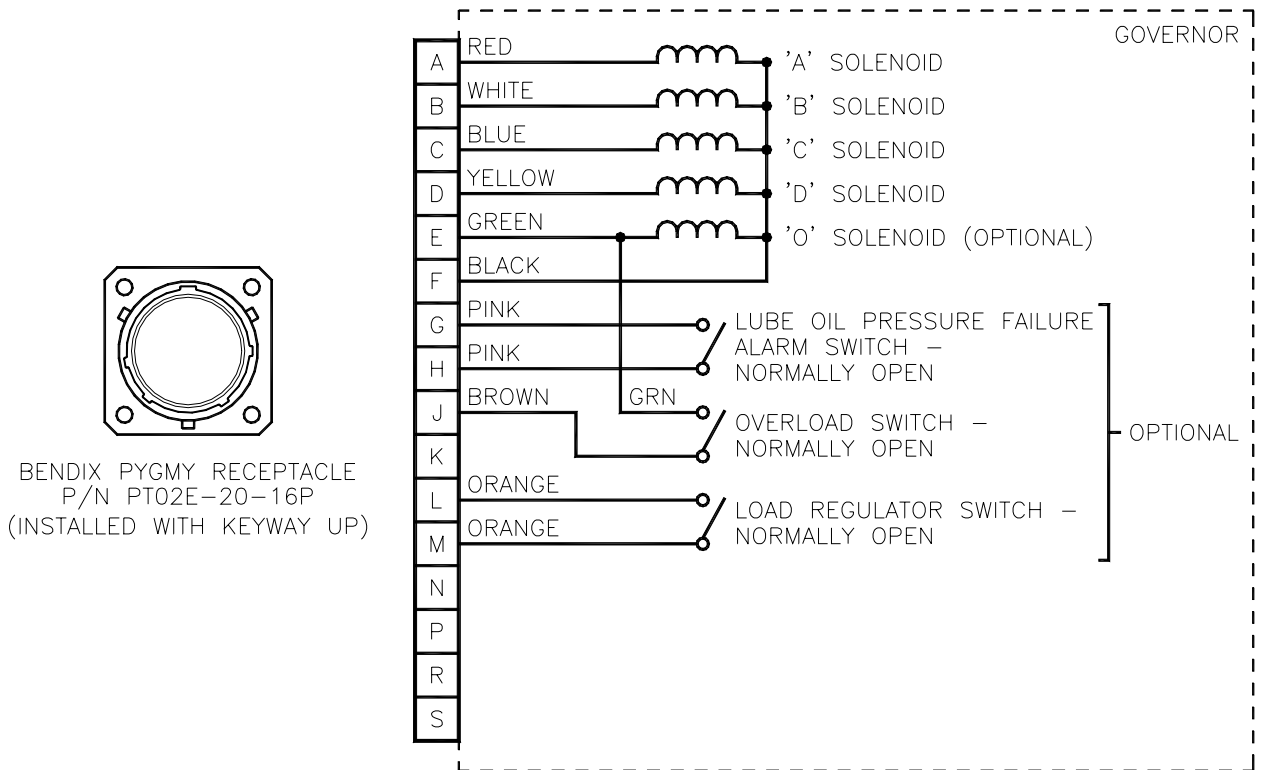

Figure 1-7b. Outline Drawing of PGEV Governor with Integral Vane Servo, Water Box, and Linear Output (Do not Use for Construction)



366-112  
89-06-14 MCL

Figure 1-8. Typical Wiring Diagram

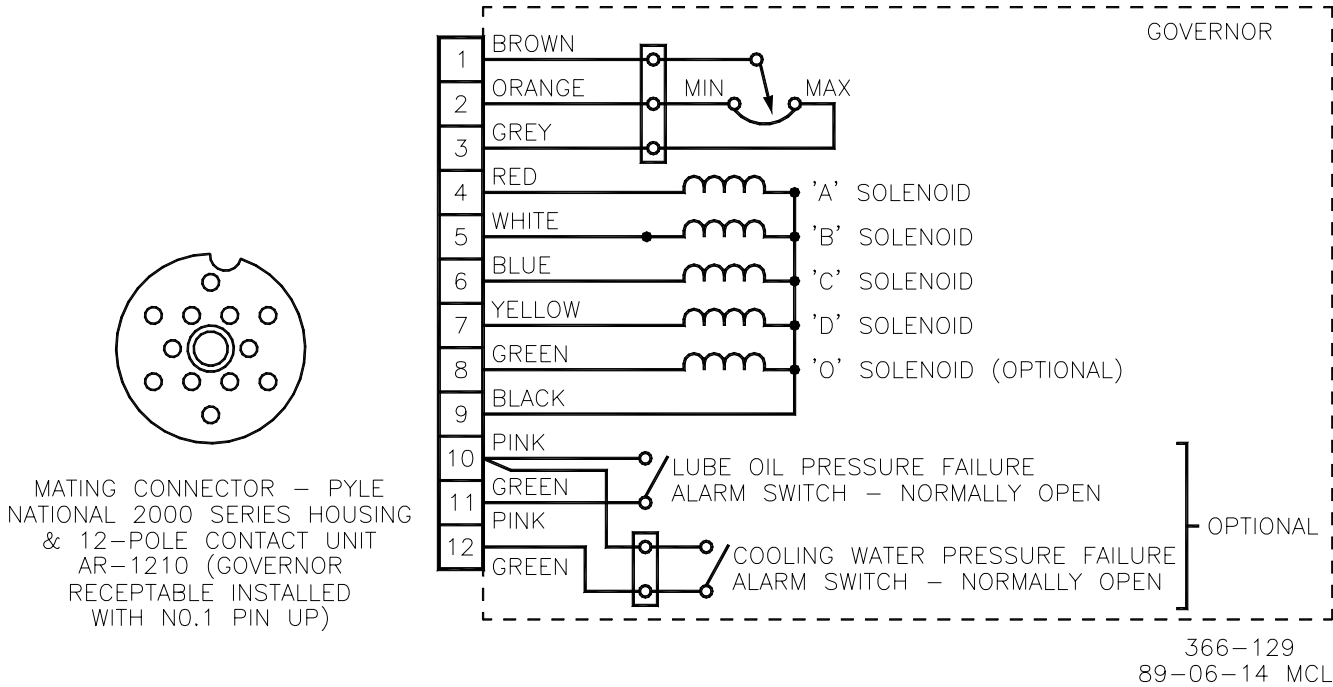

Figure 1-9. Typical Wiring Diagram for 12 Pole Connector

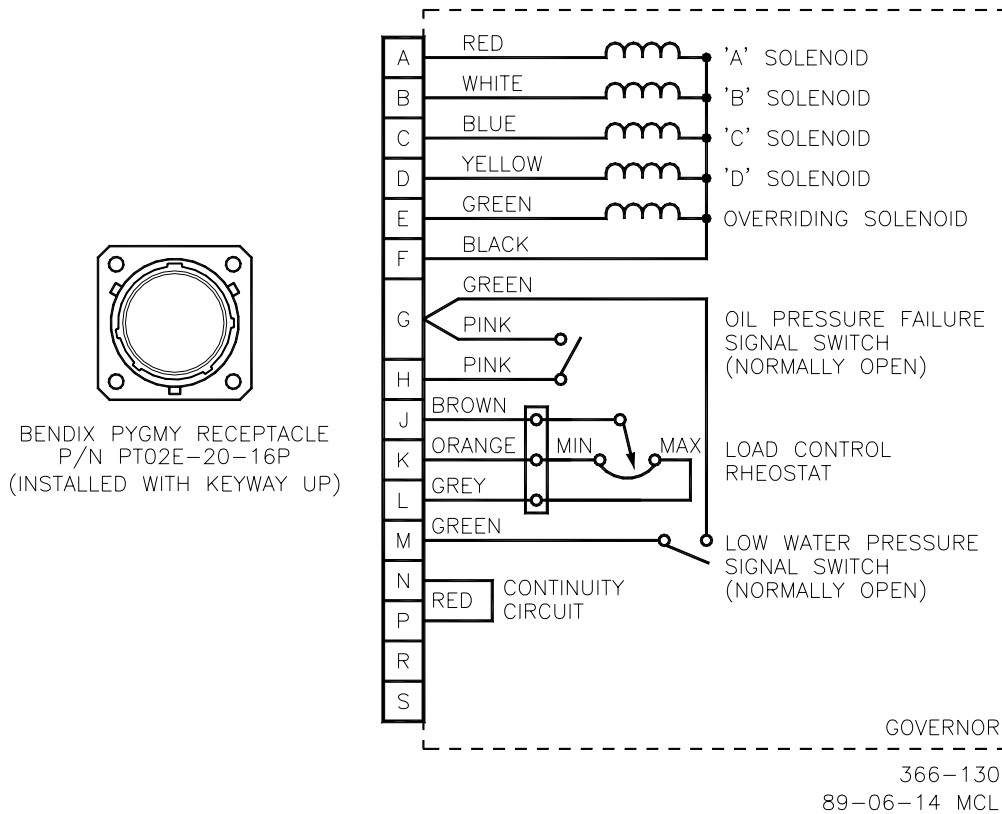

Figure 1-10. Typical Wiring Diagram for 16 Pole Connector

## Chapter 2.

# Installation and Adjustment

### Introduction

Refer to Figure 1-5, 1-6, or 1-7 for complete physical dimensions of the governor. Use care in handling the governor; be careful to avoid striking the drive shaft. Do not drop or rest the governor on its drive shaft. Such treatment could damage the governor.

### Installation

Take care to ensure that the governor is mounted squarely and that the drive connection to the engine drive is properly aligned. Do not use force when making this connection. A gasket must be used between the governor base and mounting pad. Misalignment of the governor with respect to its mounting pad, or engine drive connection, or too tight a fit between governor drive and drive coupling can result in excessive wear or seizure and may also cause undesirable "jiggle" at the output shaft.

The linkage from the governor to the engine fuel system must be properly aligned to eliminate binding and/or excessive backlash. The relationship of "piston gap" (see Figure 3-1) or terminal shaft angular position to rack position must be adjusted in accordance with the engine manufacturer's specifications.

**NOTE**

**Due to the location of the compensation cutoff port in the power cylinder wall, the governor/fuel rack linkage must be adjusted so the power piston "gap" does not exceed 1-1/32 inches (26.2 mm) at no load idle.**

Make the hydraulic and electrical connections required for the particular model governor being installed. Fill governor with oil to a level between lines on oil gauge sight glass. Fill the governor with oil to the line on the oil gauge ( on models with only one line on the gauge). Oil must be clean and of a grade suitable for the particular operating conditions (see Specifications). Recheck oil level after engine is started and add oil as necessary. Do not overfill.

**NOTE**

**Maintain the correct oil level at all times.**

**CAUTION—RESISTOR PACK**

**On governors equipped with an integral vane servo and resistor pack, the cavity around the resistor pack (rheostat) must be completely filled with oil before putting a load on the unit. Without oil for cooling, sufficient heat can be generated to overheat the resistor wiring and insulation. This Caution does not apply to governors with integral vane servos and ceramic resistors.**

To fill the cavity when the governor is on a test stand, energize or de-energize the overriding solenoid. This lowers or raises the overriding valve plunger, raising or lowering the load control pilot valve plunger and releasing oil to the rheostat cavity. When filling the rheostat cavities on the engine, move the throttle from the IDLE position to number two position. The load control pilot valve plunger changes position, allowing oil to enter the rheostat cavity. Changing load with the throttle should be done a few times to be sure the cavity is full. The cavity is full when the oil completely fills the area behind the indicator glass.

Check governor oil level and add oil if necessary.

**WARNING—OVERSPEED PROTECTION**

The engine, turbine, or other type of prime mover should be equipped with an overspeed shutdown device to protect against runaway or damage to the prime mover with possible personal injury, loss of life, or property damage.

The overspeed shutdown device must be totally independent of the prime mover control system. An overtemperature or overpressure shutdown device may also be needed for safety, as appropriate.

## Adjustments

Normally, the only requirements for putting a new or overhauled governor into service are bleeding entrapped air and adjusting the compensation needle valve to obtain maximum stability. All other operating adjustments are made during testing at the factory in accordance with the engine manufacturer's specifications and should not ordinarily require further adjustment. If found necessary to change or readjust speed settings or other operating adjustments, refer to the engine manufacturer's instructions. Do not attempt internal adjustment of the governor unless thoroughly familiar with the proper procedures.

### Compensation Needle Valve Adjustment

The compensation needle valve is an adjustable part of the compensation system. Its setting, which directly affects governor stability, depends upon the individual characteristics of the prime mover:

1. With the prime mover operating at IDLE, open the compensation needle valve several turns to cause the engine to hunt. In some cases, opening of the needle valve alone may not cause the engine to hunt, but manually disturbing the governor speed setting will induce the governor to move through its full output stroke. Allow several minutes of hunting to remove trapped air in the hydraulic circuits.
2. Close the compensation needle valve gradually until hunting is just eliminated. Keep the needle valve open as far as possible to prevent sluggishness in the governor response. The needle valve setting varies from 1/16 to 2 turns open. Never close it tight, the governor cannot operate satisfactorily when this condition exists.
3. Check the governor stability by manually disturbing the governor speed setting. The compensation adjustment is satisfactory when the governor returns to speed with only a slight over - or undershoot. Once the needle valve adjustment is correct, it is not necessary to change the setting except for large, permanent changes in temperature which affect governor oil viscosity.

## Oils For Hydraulic Controls

This is a guide in the selection of a suitable lubricating hydraulic oil for governor use. Oil-grade selection is based on viscosity change over the operating temperature range of the governor.

This is NOT intended to be used in the selection of the engine, turbine, or other type of prime mover lubricating oil.

Governor oil is both a lubricating oil and a hydraulic oil. It must have a viscosity index that allows it to perform over the operating temperature range and it must have the proper blending of additives that cause it to remain stable and predictable over this range. Governor fluid must be compatible with seal materials (nitrile, polyacrylic, and fluorocarbon). Many automotive and gas engine oils, industrial lubricating oils, and other oils of mineral or synthetic origin meet these requirements. Woodward governors are designed to give stable operation with most oils, if the fluid viscosity at the operating temperature span is within a 50 to 3000 SUS (Saybolt Universal Seconds) range. Ideally, at the normal operating temperature the viscosity should be between 100 to 300 SUS. Poor governor response or instability usually is an indication that the oil is too thick or too thin.

Excessive component wear or seizure in a governor indicates the possibility of:

1. Insufficient lubrication caused by:
  - a. An oil that flows slowly either when it is cold or during start-up.
  - b. No oil in the governor.
2. Contaminated oil caused by:
  - a. Dirty oil containers.
  - b. A governor exposed to heating-up and cooling-down cycles, which create condensation of water in the oil.
3. Oil not suitable for the operating conditions caused by:
  - a. Changes in ambient temperature.
  - b. An improper oil level which creates foamy, aerated oil.

### ZDP Additives

ZDP is corrosive to silver and tends to attack it. Oils with a ZDP antiwear additive are not recommended for use in the PGEV governor with an oil-filled side plate. The PGEV governor contains a load-control resistor with silver contacts. Increased silver contamination of the oil and wear of the load control resistor contacts may result from using an oil with a ZDP antiwear additive. PGE governors and PGEV governors without an oil-filled side plate may continue to use oils with a ZDP antiwear additive, as the oil does not come into contact with the silver contacts.

Zinc Dialkyldithiophosphates (ZDPs) are often used as antiwear additives and are found in many common hydraulic and engine oils. Governors do not normally require antiwear additives, but under certain marginal lubrication conditions may benefit from their use.

Operating a governor continuously beyond the high limit temperature of the oil will result in oil oxidation. This is identified by varnish or sludge deposits on the governor parts. To reduce oil oxidation, lower the governor operating temperature with a heat exchanger or other means, or change to an oil more resistant to oxidation at the operating temperature.

**WARNING—OVERSPEED**

A loss of stable governor control and possible Prime Mover overspeed may result if the viscosity exceeds the 50 to 3000 SUS range.

Specific oil viscosity recommendations are given on the chart. Select a readily available good brand of oil, either mineral or synthetic, and continue using it. Do not mix the different classes of oils. Oil that meets the API (American Petroleum Institute) engine service classification in either the "S" group or the "C" group, starting with "SA" and "CA" through "SF" and "CD" is suitable for governor service. Oils meeting performance requirements of the following specifications are also suitable. MIL-L-2104A, MIL-L-2104B, MIL-L-2104C, MIL-L-46152, MIL-L-46152A, MIL-L-46152B, MIL-L-45199B.

Replace the governor oil if it is contaminated. Also change it if it is suspected of contributing to governor instability. Drain the oil while it is still hot and agitated; flush the governor with a clean solvent having some lubricity before refilling with new oil.

**CAUTION—SOLVENTS**

Be sure the solvent is compatible with seals. If in doubt contact Woodward.

If drain time is insufficient for the solvent to completely drain or evaporate, flush governor with the same oil it is being refilled with to avoid dilution and possible contamination of the new oil,

To avoid recontamination, the replacement oil should be free of dirt, water, and other foreign material. Use clean containers to store and transfer oil.

Oil that has been carefully selected to match the operating conditions and is compatible with governor components should give long service between oil changes. For governors operating under ideal conditions, i.e., minimum exposure to dust and water and within the temperature limits of the oil, oil changes can be extended to two or more years. If available, a regularly scheduled oil analysis is helpful in determining the frequency of oil changes.

Any persistent or reoccurring oil problems should be referred to a qualified oil specialist for solution.

The recommended oil temperature for continuous governor operation is 140°F (60°C) to 200°F (93°C). Measure the temperature of the governor or actuator on the outside lower part of the case. The actual oil temperature will be slightly warmer, approximately 10°F (6°C). The ambient temperature range is -20°F (-29°C) to 200°F (93°C).

**NOTE**

The primary concern is for the hydraulic fluid properties in the governor.

**Oil Level**

Fill the governor with oil to the mark on the sight gauge, recheck with the engine idling. Oil must be visible in the glass on the gauge during all other conditions.

If additional information for oil properties is required, see manual 25071, *Oils for Hydraulic Controls*.

VISCOSITY COMPARISONS				
CENTISTOKES (CST, CS, OR CTS)	SAYBOLT UNIVERSAL SECONDS (SUS) NOMINAL AT 100 DEGREES F	SAE MOTOR (APPROXIMATE)	SAE GEAR (APPROXIMATE)	ISO
15	80	5W		15
22	106	5W		22
32	151	10W	75	32
46	214	10	75	46
68	310	20	80	68
100	463	30	80	100
150	696	40	85	150
220	1020	50	90	220
320	1483	60	115	320
460	2133	70	140	460

250-087  
97-11-04 skw

Figure 2-1. Viscosity Comparison Chart

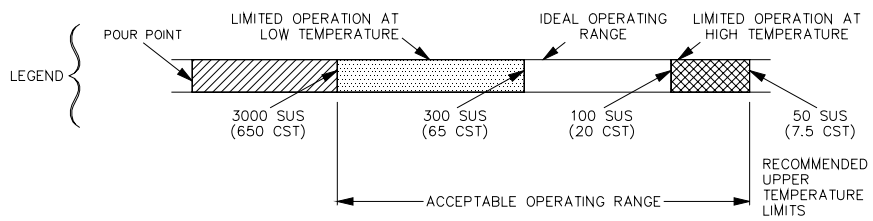
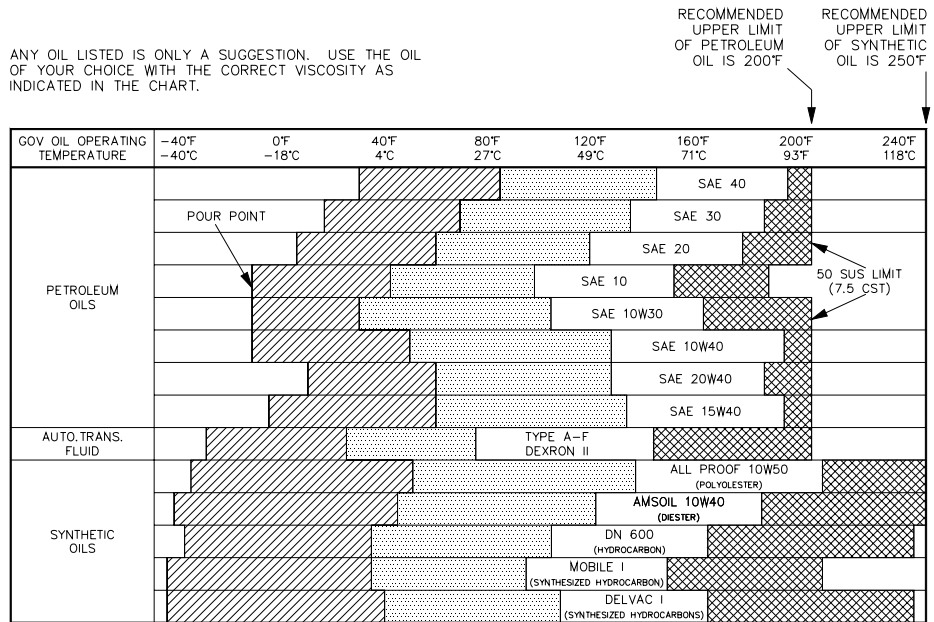

250-079

Figure 2-2. Oil Comparison Chart

# Chapter 3.

## Principles of Operation

### Introduction

For purposes of description, the PGE and PGEV governors are considered to consist of three major functional sections: a basic governor section, a speed setting section, and a load control section.

### Basic Governing Section

(Figure 3-1)

This section consists of an oil pump, two accumulators, a speeder spring, a flyweight head assembly, a thrust bearing, a pilot valve plunger, a rotating bushing, a buffer compensation system, and a power cylinder.

The governor drive shaft passes through the governor base and engages the rotating bushing. The pump supplies pressure oil for operation of the basic governor section, the speed setting section, the load control system (except applications using a remote vane servo, or where engine oil is supplied to the control system), and all other auxiliary features or devices.

A spring loaded accumulator and relief valve system maintains governor oil operating pressure. When operating pressure is reached the spring pressure is overcome and the oil is released to sump.

Direction of rotation is normally determined by the engine manufacturer or Woodward Governor Company. Governor rotation is either fixed cw, fixed ccw, or reversible. Figure 3-1 shows the arrangement for reversible rotation with four check valves in the oil pump passages. For fixed rotation the four check valves are removed and two plugs are placed in two of the passages to allow only one direction of flow.



#### NOTE

**Governors for locomotives are built for one direction of rotation.**

The governor drive rotates the oil pump and pilot valve bushing. The flyweight head assembly is driven by the rotating pilot valve bushing. A thrust bearing rides on top of the flyweight-head toes permitting the rotational motion between the downward force of the speeder spring and the upward force of the flyweights.

The relative motion between the bushing and plunger minimizes static friction. There are several styles of flyweight head assemblies available. The exact style used depends upon the engine drive train to the governor. A solid head is used where the drive is relatively free of torsional vibrations. "Spring driven" and "spring driven oil damped" head assemblies are used to attenuate objectionable levels of torsional vibration which may be imparted to the governor from the engine. These vibrations may originate from a source other than the drive itself but reach the governor through the drive connection. Unless minimized or eliminated, these vibrations are sensed as speed changes and the governor will continually adjust the fuel rack in an attempt to maintain a constant speed.

The greater of two opposing forces moves the pilot valve plunger up or down. Flyweight force tends to lift the plunger while speeder spring force tends to lower the plunger. When the engine is on speed at any speed setting, these forces are balanced and the flyweights assume a vertical position. In this position, the control land on the pilot valve plunger is centered over the regulating port(s) in the rotating bushing. No oil, other than leakage make up, flows to or from the buffer compensation system or power cylinder. A change in either of these two forces will move the plunger from its centered position. The plunger will be lowered (1) when the governor speed setting is unchanged but an additional load slows the engine and governor (thereby decreasing flyweight force), or (2) when engine speed is unchanged but speeder spring force is increased to raise the governor speed setting. Similarly, the pilot valve plunger will be raised (1) when the governor speed setting is unchanged but load is removed from the engine causing an increase in engine and governor speed (and hence, an increase in flyweight force), or (2) where engine speed is unchanged but speeder spring force is reduced to lower the governor speed setting. When the plunger is lowered (an underspeed condition), pressure oil is directed into the buffer compensation system and power cylinder to raise the power piston and increase fuel. When lifted (an overspeed condition), oil is permitted to drain from these areas to sump and the power piston moves downward to decrease fuel.

The buffer piston, springs, and needle valve in the hydraulic circuits between the pilot valve plunger and power cylinder make up the buffer compensation system. This system functions to stabilize the governing action by minimizing over or undershoot following a change in governor speed setting or a change in load on the engine. It establishes a temporary negative feedback signal (temporary droop) in the form of a pressure differential which is applied across the compensation land of the pilot valve plunger. The flow of oil into or out of the buffer system displaces the buffer piston in the direction of flow. This movement increases the loading on one spring while decreasing the load on the other and creates a slight difference in the pressures on either side of the piston with the higher pressure on the side opposite the spring being compressed. These pressures are transmitted to opposite sides of the plunger compensation land and produce a net force, upward or downward, which assists in re-centering the plunger whenever a fuel correction is made.

### **Speed Setting or Load Increase**

Increasing the speed setting or increasing load on the engine at a given speed setting have an identical effect. In either case, the flyweights move inward (underspeed) due to the increase in speeder spring force or, to the decrease in centrifugal force caused by the decrease in engine speed as load is added. The movement of the flyweights is translated into a downward movement of the pilot valve plunger. This directs pressure oil into the buffer system, causing the buffer piston to move toward the power cylinder. The oil displaced by the movement of the buffer piston forces the power piston to move upward in the increase fuel direction. The oil pressures on either side of the buffer piston are simultaneously transmitted to the plunger compensation land with the higher pressure on the lower side. The net upward force thus produced is added to flyweight force and assists in restoring the balance of forces and re-centering the pilot valve plunger.

In effect, this enables the governor to cut off the additional fuel needed for acceleration by stopping the power piston when it has reached a point corresponding to that amount of fuel required for steady state operation at the new higher speed or load. As the engine continues to accelerate toward the set speed, the compensation force is gradually dissipated to offset the continuing increase in flyweight force. This is done by equalizing the pressures on each side of the compensation land through the needle valve at a rate proportional to the continued rate of acceleration. The rate of dissipation is the same as the rate of increase in flyweight force, the pressure differential is reduced to zero at the instant flyweight force becomes exactly equal to speeder spring force. This minimizes speed overshoot and permits the governor to quickly re-establish stable operation. The needle valve setting determines the rate at which the differential pressure is dissipated and allows the governor to be "matched" to the characteristics of the engine. The compressed buffer spring returns the buffer piston to its centered position as the pressure differential is dissipated.

Whenever large changes in speed setting or load are made, the buffer piston will move far enough to uncover a bypass port in the buffer cylinder. This limits the pressure differential across the buffer piston and permits oil to flow directly to the power cylinder. Thus, the power piston is made to respond quickly to large changes in speed setting or load.

### **Speed Setting or Load Decrease**

Decreasing the speed setting or load on the engine at a given speed setting are identical in effect and cause a reverse action to that described above. The flyweights move outward (overspeed), lifting the pilot valve plunger and allowing oil to drain from the buffer compensation system. The buffer piston moves away from the power cylinder, permitting oil to drain from the area under the power piston which then moves downward in the decrease fuel direction. The differential pressures acting across the compensation land produce a net downward force, assisting the speeder spring in re-centering the pilot valve plunger slightly before the engine has fully decelerated. This stops power piston movement when it has reached a point corresponding to that amount of fuel required for steady state operation at the new lower speed or load. Dissipation of the compensation force in the same manner as previously described and minimizes speed undershoot.

### **Compensation Cutoff**

With large decreases in speed or load, the power piston moves to the "no fuel" position and blocks the compensation oil passage between the power cylinder and needle valve to prevent normal equalization of the compensation pressures. This holds the buffer piston off center and increases the level of the pressure transmitted to the upper side of the plunger compensation land. The increased pressure differential, added to the effect of the speeder spring, temporarily increases the governor speed setting. The governor will thus begin corrective action as soon as engine speed drops below the temporary speed setting and start the power piston upward to restore the fuel supply in sufficient time to prevent a large underspeed transient. The above action is sometimes referred to as "compensation cutoff". When the upward movement of the power piston again uncovers the compensation oil passage, normal compensating action will resume and stabilize engine speed at the actual speed setting of the governor.

**NOTE**

Due to the location of the compensation cutoff port in the power cylinder wall, the governor/fuel rack linkage must be adjusted so the power piston "gap" does not exceed 1-1/32 inches (26.2 mm) at idle no load.

## Speed Setting Section

(Figure 3-1)

This section consists of a speed setting cylinder, a speed setting pilot valve plunger housed within a rotating bushing, four speed setting solenoids, a triangular plate, and a restoring linkage mechanism.

### General

The speed setting section provides a method of changing the compression (force) of the speeder spring which opposes flyweight centrifugal force. It does this by controlling the position of the speed setting piston in the speed setting cylinder. When control oil is admitted to the cylinder, the piston moves downward, compressing the speeder spring and raising the speed setting. When oil is allowed to drain from the cylinder, the piston spring forces the piston upward, reducing speeder spring force and lowering the speed setting. The flow of oil into or out of the speed setting cylinder is regulated by the speed setting pilot valve plunger in the rotating bushing. The plunger is controlled by the solenoids which provide incremental control of speed in equally spaced steps. An integral gear on the governor flyweight head drives the bushing through a splined mating gear on the lower end of the bushing.

The rate of movement of the speed setting piston over its full downward stroke (idle to maximum speed) is usually retarded to occur over some specific time interval to minimize exhaust smoke during accelerations. This is done by admitting governor pressure oil into the rotating bushing through an orifice which registers with the main supply port once in every revolution of the bushing. This retards the rate at which oil is supplied to the control port in the bushing and thus, the rate of oil flow to the speed setting cylinder. The diameter of the orifice determines the specific time interval which may be anywhere within a nominal range of 1 to 50 seconds. Typical engine acceleration periods for switching and suburban service is approximately 5 seconds; for freight or passenger service, approximately 15 to 30 seconds; turbo-supercharged engines the timing may be as much as 50 seconds to permit the supercharger to accelerate with the engine.

On turbo-supercharged units, the rate of movement of the speed setting piston over its full upward stroke (maximum to idle speed) is also retarded to prevent compressor surge during decelerations. This timing may be anywhere within a nominal range of 1 to 15 seconds. In this case, a vertical slot in the drain land of the pilot valve plunger registers with a second orifice in the rotating bushing once each revolution. This retards the rate at which the oil is allowed to drain from the speed setting cylinder.

## Speed Setting

Three of the four speed setting solenoids, A, B, and C, actuate the pilot valve plunger by controlling the movement of the triangular plate which rests on top of the floating lever attached to the plunger. The fourth solenoid D controls the position of the rotating bushing with respect to the plunger. Energizing the A, B, and C solenoids, singly or in various combinations, depresses the triangular plate a predetermined distance for each combination. The downward movement of the plate is transmitted through the floating lever to un-center the plunger. This directs intermittent oil pressure to the speed setting cylinder, forcing the speed setting piston downward to increase the Governor speed setting. Energizing the D solenoid pushes the rotating bushing downward and opens the control port to drain oil from the speed setting cylinder and thus decrease the speed setting. An identifying letter will be found on the solenoid bracket adjacent to each solenoid.

Figure 3-2 is an additional aid in understanding the various governor components. The oil passages are simplified and color coded for ease in following the oil flow through the system. The lower half of the governor functions to maintain a constant engine speed by controlling fuel flow to the engine cylinders. The upper half of the governor consists of the column and cover and internal related parts for changing governor speed setting, the control valve for the load regulator, and shutdown and protective devices.

Advancing or retarding the throttle control from one step to the next energizes or de-energizes the solenoids in various combinations to increase or decrease engine speeds in approximately equal increments.

Whenever a change in speed setting is made, the movement of the speed setting piston, downward or upward, is transmitted or fed back through the restoring linkage and floating lever to re-center the pilot valve plunger. This stops the flow of oil into or out of the speed setting cylinder at a position corresponding to that speed setting.

## Speed Setting Increase

When one or more of the solenoids is energized (or de-energized) by moving the throttle to a higher step, the solenoid plungers move downward and depress the triangular plate and in turn the floating lever. Since the right end of the lever is attached to the lower end of the restoring link, the left end of the lever is forced downward to un-center (lower) the pilot valve plunger. This directs intermediate pressure oil to the speed setting cylinder which forces the piston downward to further compress the speeder spring and thereby increase the speed setting.

The downward movement of the piston is transmitted through the restoring linkage to the right end of the floating lever and causes it to move downward a proportional amount. This allows the loading spring under the pilot valve plunger to raise the plunger, with the floating lever pivoting about the triangular plate. This action will continue until the plunger is again re-centered, stopping the flow of oil to the speed setting cylinder at the instant the piston reaches the new lower position corresponding to the increased speed setting.

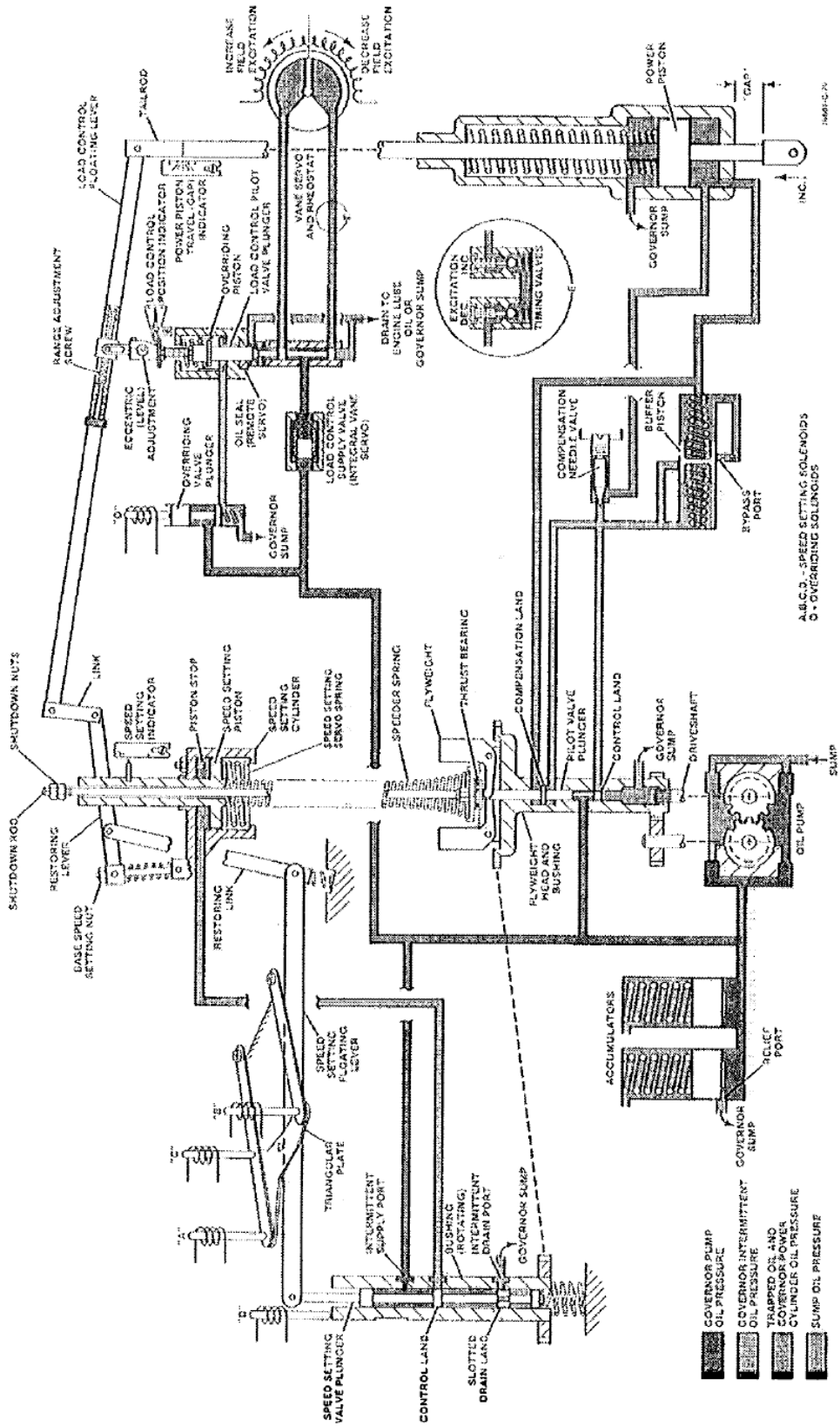

Figure 3-1. Schematic Diagram of Typical PGEV Governor

## Speed Setting Decrease

Moving the throttle to a lower step de-energizes (or energizes) one or more of the solenoids and causes a reverse action to that of speed setting increase. The triangular plate moves upward, being held in contact with the solenoid plungers by a loading spring. This allows the loading spring under the pilot valve plunger to un-center (raise) the plunger which allows oil to drain from the speed setting cylinder. The upward movement of the speed setting piston is transmitted through the restoring linkage to re-center the plunger.

## Normal Shutdown

(See Figure 3-1)

Under normal operating conditions, the engine is shut down by moving the throttle to the STOP position. This energizes the D solenoid pushing the rotating bushing down and opening the control port to drain the oil from the speed setting cylinder. The speed setting piston then moves up lifting the shutdown nuts and shutdown rod in the process. This lifts the governor pilot- valve plunger, draining oil from the buffer compensation system and allowing the power piston to move down to the shutdown (no fuel) position. The upward movement of the speed-setting piston is limited by the stop screw.

The speed-setting-piston stop screw (Figure 3-1) limits piston rod travel. Restarting the engine is easier because less oil volume is required to move the speed setting piston down.

## Load Control Section

(Figure 3-1)

In most governor applications, the primary function of the governor is to automatically maintain a specific engine speed under varying load conditions by controlling the fuel flow to the engine. With the locomotive governor, a secondary function is included to maintain a constant engine power output at each specific speed setting. Thus, for each throttle setting, there is both a constant engine speed and a predetermined, fixed rate of fuel flow required. To satisfy both conditions, the load on the engine must be adjusted as the locomotive operating conditions (speed and locomotive auxiliaries); vary and it is the function of the load control to do this.



### NOTE

**Maintaining a constant engine speed does not mean that locomotive road speed will also be constant.**

Control of engine load is achieved by regulating engine speed and fuel setting. This is done by adjusting the generator field-excitation current through the use of a vane servo controlled variable resistance in the generator-field circuit. The vane servo is controlled by the load control pilot valve and related linkage in the governor. The load-control linkage is so arranged that for each speed setting there is only one fuel setting (engine power output) at which the load- control pilot-valve-plunger will be centered.

An increase or decrease in either governor speed setting or engine load will change fuel flow. The power piston moving in either the increase or decrease fuel direction will (through the floating lever linkage) move the load-control pilot valve up or down respectively. The vane servo decreases or increases field excitation and in turn engine load.

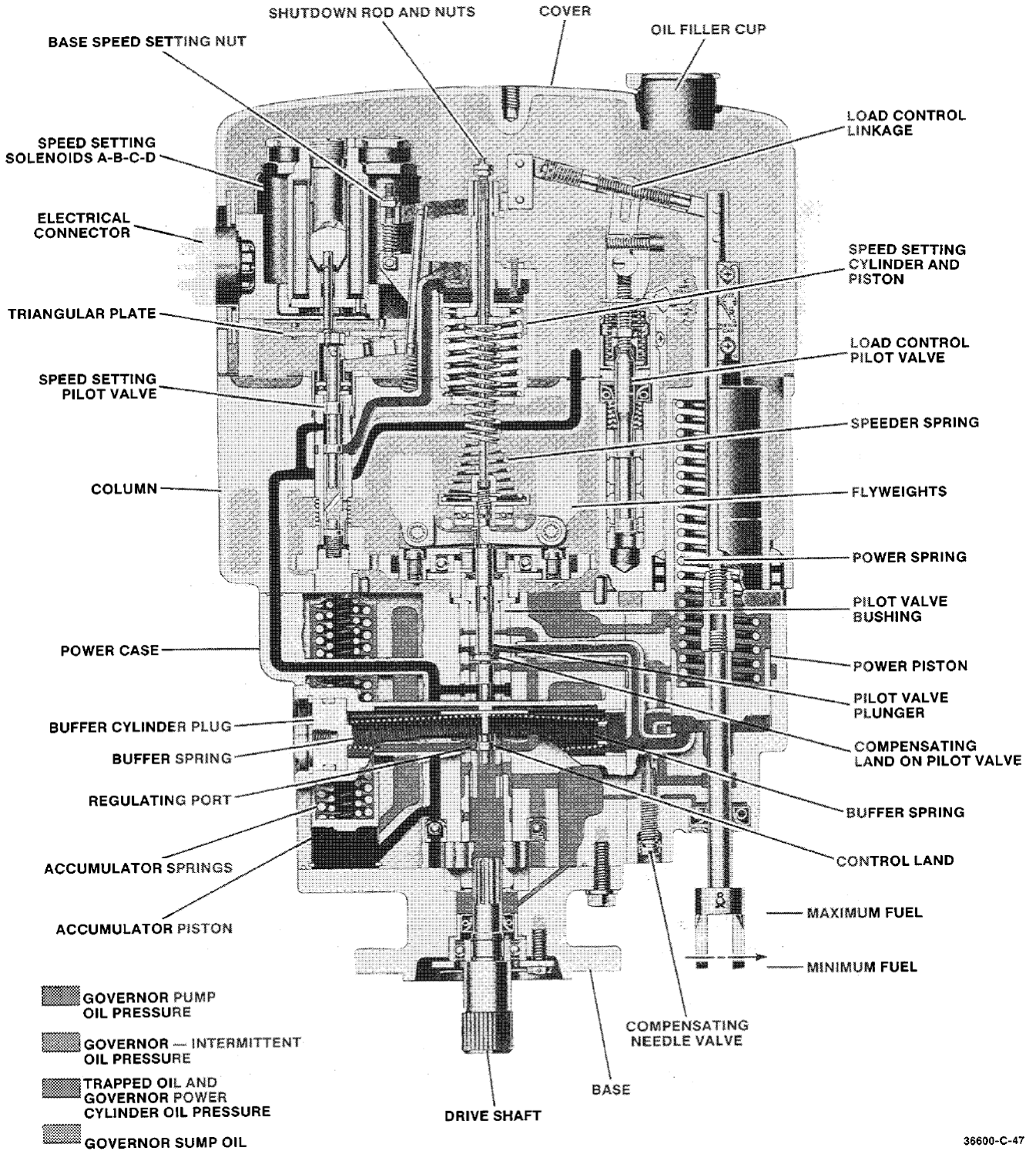

36600-C-47

Figure 3-2. Sectional Diagram PGE Governor

In some applications, the vane servo is a remote unit connected to the governor through tubing and uses oil from the engine lubricating system for its operation. The vane servo may be either a rotary or piston type. In other applications, the vane servo is integral with the governor and uses governor oil for its operation. The integral unit consists of a commutator about which a set of moveable brushes rotate to change the value of the resistance in the generator field excitation circuit. The brushes are driven by the servomotor which, in turn, is controlled by the load-control pilot valve. Remote units, usually provided by the locomotive manufacturer, differ in size and construction from the integral unit, however, the method of control and operation is essentially identical.

The load-control pilot valve plunger is suspended from the load-control floating lever. The lever is connected to the power-piston tailrod at one end and to the speed setting piston rod at the other end. Any movement of either or both pistons causes a corresponding movement of the plunger which is housed within a non-rotating bushing. Pressure oil is supplied to the plunger either externally from the engine lubricating oil system or internally from the governor oil pump. Two lands on the plunger control the flow of oil to or from the vane servo. When internal governor oil is used for operation of the vane servo, a supply (cutoff) valve is provided in the oil supply passage to the load-control valve. The supply valve is closed during starting so that all available oil from the governor oil pump is delivered to the speed setting and power pistons to quickly open the fuel injectors and thus minimize cranking time. After the engine starts, the increase in governor oil pressure opens the supply valve and restores normal load control system operation. This valve also serves a secondary system to control the vane servo response rate (timing).

## Operation with Load Increase

Assuming that the train is in motion and that the electrical load is balanced with the desired engine fuel (power output) at the existing governor-speed setting, the load control system will be stationary with the pilot valve plunger centered. When a compressor turns on (or any situation occurs that increases load) electrical load on the generator is increased and transmitted to the engine. Engine speed decreases and the governor increases fuel flow to bring the engine back to the preset speed while still carrying the added load.

The power piston moves upward simultaneously raising the right end of the load control floating lever which, in turn, lifts the pilot valve plunger above center. This directs pressure oil through the upper control port in the bushing to the decrease-excitation side of the vane servo while opening the lower port in the bushing to drain. With a reduction in load, the engine will overspeed and the governor will then act to reduce fuel. The reduction in field excitation current and engine fuel will continue until the power piston and floating lever have returned to their original position. This re-centers the pilot valve plunger and stops the servomotor. Consequently, the electrical load is reduced sufficiently to again balance the required engine power output (fuel flow). At this point, the engine will have also returned to an on-speed condition.

## Operation with Load Decrease

Under the same conditions as stated above, a decrease in electrical load will reduce engine load and cause the engine to decrease fuel and, in the process, lower the right end of the floating lever. This moves the pilot-valve plunger below center and directs pressure oil through the lower control port in the bushing to the increase excitation side of the vane servo. With an increase in load, the engine will underspeed and the governor will act to increase fuel. This increase in field excitation current and engine fuel will continue until the power piston and floating lever have returned to their original positions. This re-centers the pilot-valve plunger and stops the servomotor. Consequently the electrical load is increased sufficiently to again balance engine-power output with the engine on-speed.

## Operation with Speed Setting Increase

Advancing the throttle to a higher step causes the piston to move downward. This lowers the left end of the load-control floating lever which displaces the load control pilot valve plunger below center. Pressure oil is directed to the increase-excitation side of the vane servo. The governor acts to increase fuel to compensate for both the increase in speed setting and the simultaneous increase in electrical load. As the power piston moves upward, it raises the right end of the floating lever to return the pilot-valve plunger to its centered position. This stops the servomotor as the power piston reaches its new higher position corresponding to the increased speed setting. At this point, the electrical load has been sufficiently increased to balance the increase in engine power output.

## Operation with Speed Setting Decrease

Moving the throttle to a lower speed setting causes the speed setting piston to move upward. This raises the left end of the load-control floating lever and lifts the pilot valve plunger above center. Pressure oil is directed to the decrease excitation side of the vane servo. The governor acts to decrease fuel to compensate both for the decrease in speed setting and the simultaneous decrease in electrical load. As the power piston moves downward, it lowers the right end of the floating lever to return the pilot valve plunger to its centered position. This stops the servomotor as the power piston reaches its new lower position corresponding to the decreased speed setting. At this point, the electrical load has been sufficiently decreased to balance the decrease in engine power output.

## Load Control Balancing

The rate of vane servo movement (timing) must be controlled to effect a controlled rate of load application and to provide stability of the overall system. Several methods are commonly used to provide a balanced action and are identical in that they restrict the flow of oil to and from the vane servo and thus determine its rate of movement.

In some governors, the oil flow is restricted by the number, size and position of a group of orifice holes (restricted porting) in the load control bushing, which are opened and closed by the movement of the pilot valve plunger. With this arrangement, a progressively increasing (or decreasing) rate of movement occurs depending on the degree of movement of the plunger. These rates will not necessarily be the same in both directions.

Governors used with remote servos may have a separate timing valve assembly consisting of two adjustable ball check valves in series within a common housing. The assembly may be externally mounted on the governor or remotely located and connected into one of the lines between the governor and servo. The valves are individually adjustable to provide the desired maximum rate of movement over the full travel of the servomotor in either the increase or decrease excitation direction.

Governors with an integral-vane servo may use a similar arrangement to the timing valve assembly, except that the ball valves are individually housed and internally installed in the top of the governor column.

## Minimum or Maximum Field Start Adjustment

The load control system in the governor may be set up for either "Minimum or Maximum" field start.

**Minimum Field Start**—builds up engine load slowly, providing a smooth take-up of slack in the train. The load control pilot valve is mechanically set above center with the throttle in IDLE position. Field excitation is retarded due to the retarded position of the pilot valve plunger. The vane servo rheostat remains in the minimum excitation position until the throttle is moved in the increase speed direction. This lowers the load control pilot valve to the re-center position and beyond to increase excitation.

**Maximum Field Start**—enables the engine load to build up immediately, for rapid accelerations. The load control pilot valve is mechanically set below center with the throttle in IDLE position. Field excitation is advanced due to the advanced position of the pilot valve plunger. The vane servo rheostat remains in the maximum excitation position until the throttle is moved in the increase speed direction to raise the load control pilot valve.

## Load Control Override (Optional)

Under certain conditions of locomotive operation (transition, maximum-field start and wheel slip), it is sometimes desirable or necessary to override the normal action of the governor load control mechanism to cause a reduction in generator excitation current when it would normally respond by increasing excitation current.

The load control override mechanism in the governor consists of an overriding solenoid (ORS), a two-position overriding control valve, and an overriding piston within a cylinder which surrounds the upper end of the load control pilot-valve plunger. See Figure 3-1.

Energizing the ORS pushes the overriding valve plunger down, closing the drain to Sump and allowing pressure oil to flow into the overriding cylinder. The overriding piston moves upward, contacting the spring collar on the stem of the pilot-valve plunger and lifting the plunger above its centered position. The slot in the link connecting the pilot-valve plunger to the floating lever permits the plunger to rise independently of the lever. This directs pressure oil to the decrease-excitation side of the vane servo, thus reducing generator output. When the ORS is de-energized, the overriding-valve plunger moves upward, closing the pressure port and allowing the oil to drain from the overriding cylinder. This restores normal load-control system operation.

**Transition**—A condition where the electrical circuits between the generator and traction motors are automatically changed, as road speed changes, to provide more efficient transmission of electrical power. Overriding is used in this circumstance to protect the switchgear from arcing which would occur during transition if high current existed in the traction motor circuits.

**Modified Maximum Field Start**—A variation used in some applications where the load control mechanism is arranged for maximum field start but it is desirable to hold the vane servo rheostat in the minimum excitation position at idle speed. Normal operation is restored when the throttle is advanced to the first step, allowing the vane servo to increase excitation toward maximum as the train starts.

**Wheel Slip**—When rail and load conditions cause drive wheel slip, an immediate decrease in load occurs at the traction motors and generator. The resulting increase in engine speed would normally cause the load-control system to respond by increasing generator output at a time when there is no demand. Overriding is used in this circumstance in conjunction with wheel-slip relays, if the locomotive is so equipped, to cause a reduction in generator output until wheel slippage ceases.

Operation of the ORS is done through automatic switching devices.

**Fast Unloading**—may be used in conjunction with the load control override mechanism. It provides a quick unloading of the integral-vane servo. Fast unloading cannot be used for remote-servo applications using external timing valves. Two methods are available. (1) The lower end of the load-control pilot-valve plunger has an additional land. An additional port in the bushing bypasses the restricted port in the bushing. When the ORS energizes, the plunger un-centers upward and oil is released through the extra port for fast unloading of the vane servo, (2) The plunger has an additional land on its lower end. Instead of a bypass port, the bushing has small orifice holes in one side of the bushing. A radial slot is located in the bushing and midway between the orifice holes. As the ORS energizes, the plunger un-centers upward releasing oil through the orifice holes first and if a large displacement of the pilot valve takes place, oil is released from the servo through both the orifice holes and the radial slot. Both methods allow the vane servo to move rapidly in the direction of minimum excitation.

### Integral Vane Servo Assembly (Optional)

The integral-vane servo is used with low wattage pilot or amplifier type excitation systems. It functions in conjunction with the load control mechanism in the governor to automatically regulate generator output and thereby maintain a constant engine-power output at each throttle setting.

Vane servos use either a resistor pack or a ceramic resistor. Figure 3-3a shows a vane servo with a resistor pack. A vane servo with a ceramic resistor appears in Figure 3-3b.

Both servos have a vane-type rotary servomotor. Drain oil flows through the covers of both units to cool the resistor pack or the ceramic resistor. The commutator and resistor pack or ceramic resistor are electrically insulated from the vane servo unit.

The vane servo shaft output shaft has external serrations with one missing tooth. The slot formed by the missing tooth mates with a ridge on the brush drive shaft to make sure that the two shafts assemble correctly.

**i** **NOTE**  
 Contact Woodward for details and actual limits.

Whenever the load-control pilot valve in the governor column is un-centered, pressure oil is directed to one or the other side of the vane servo while the opposite side is opened to drain. This causes the vane to rotate which, in turn, rotates the contact-brush assembly about the commutator. The position of the brushes on the commutator segments determines the circuit resistance and thereby the generator field-excitation current.

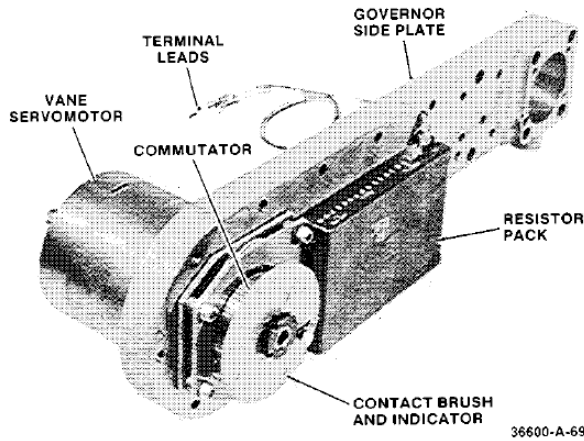

Figure 3-3a. Integral Vane Servo (with Resistor Pack Assembly)

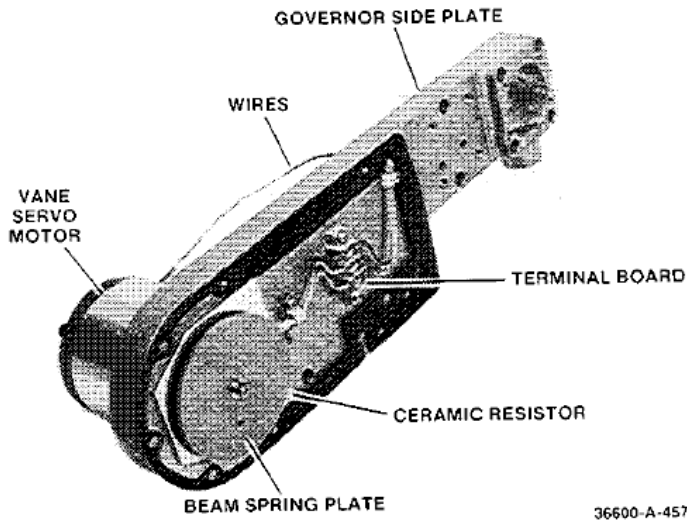

Figure 3-3b. Integral Vane Servo (with Ceramic Resistor)

## Lube Oil Pressure Shutdown at Alarm

(See Figure 3-4)

Engine oil pressure is directed to the oil-pressure diaphragm. The shutdown-valve plunger is connected to the diaphragm which has three forces acting on it; load-spring and engine-oil pressures act to move it to the right, governor speed-setting-servo oil acts to move it to the left. Normally, load-spring and engine-oil pressures hold the diaphragm and shutdown-valve plunger to the right, permitting oil to the left of the shutdown piston to drain to sump. When engine lube-oil pressure drops below a safe level, speed-setting-servo oil pressure (which is dependent on the speed setting and on the rate of the speed-setting servo spring) overcomes the load spring and engine-oil pressure forces and moves the diaphragm and shutdown-valve plunger to the left. Governor pressure oil is directed around the shutdown-valve plunger to the shutdown piston and moves it to the right. The shutdown piston moves the inner spring and shutdown plunger to the right. The differential piston allows a high engine-lube oil-pressure trip point without a corresponding increase in the speed-setting-servo oil pressure. The engine-lube oil pressure required to initiate shutdown is increased. When the shutdown plunger moves sufficiently, it trips the alarm switch.

In addition, oil trapped above the governor speed-setting-servo piston flows around the smaller diameter on the left end of the shutdown plunger and drains to sump. This action allows the speed-setting-servo spring to raise the speed setting servo piston. When the piston moves up sufficiently, the piston rod lifts the shutdown nuts and rod. The shutdown rod lifts the governor pilot-valve plunger. When it is lifted above its centered position, oil trapped below the power piston drains to sump and the power piston moves to the fuel off position



### NOTE

**The shutdown plunger must be pushed back in to restart the engine except on modulating governors.**

Adjustment of the spring seat in the field is not recommended. This adjustment biases the lube-oil-pressure required for shutdown. Adjust the spring seat on a test stand during testing after an overhaul. No further adjustment should be necessary.

## Water Pressure Shutdown at Alarm

A water box monitors engine water pressure to shut down the engine when water pressure is too low. This device operates like the Lube Oil Shutdown device described above except that low water pressure initiates shutdown of the engine.

## Bypass Valve

Governor pressure oil is supplied to the shutdown piston in one of two ways, depending on the speed setting. At rated speed settings, the bypass valve is moved down off its seat by the speed-changing mechanism. Governor pressure oil passes directly to the shutdown piston and immediately initiates engine shutdown in the event of lube-oil failure.

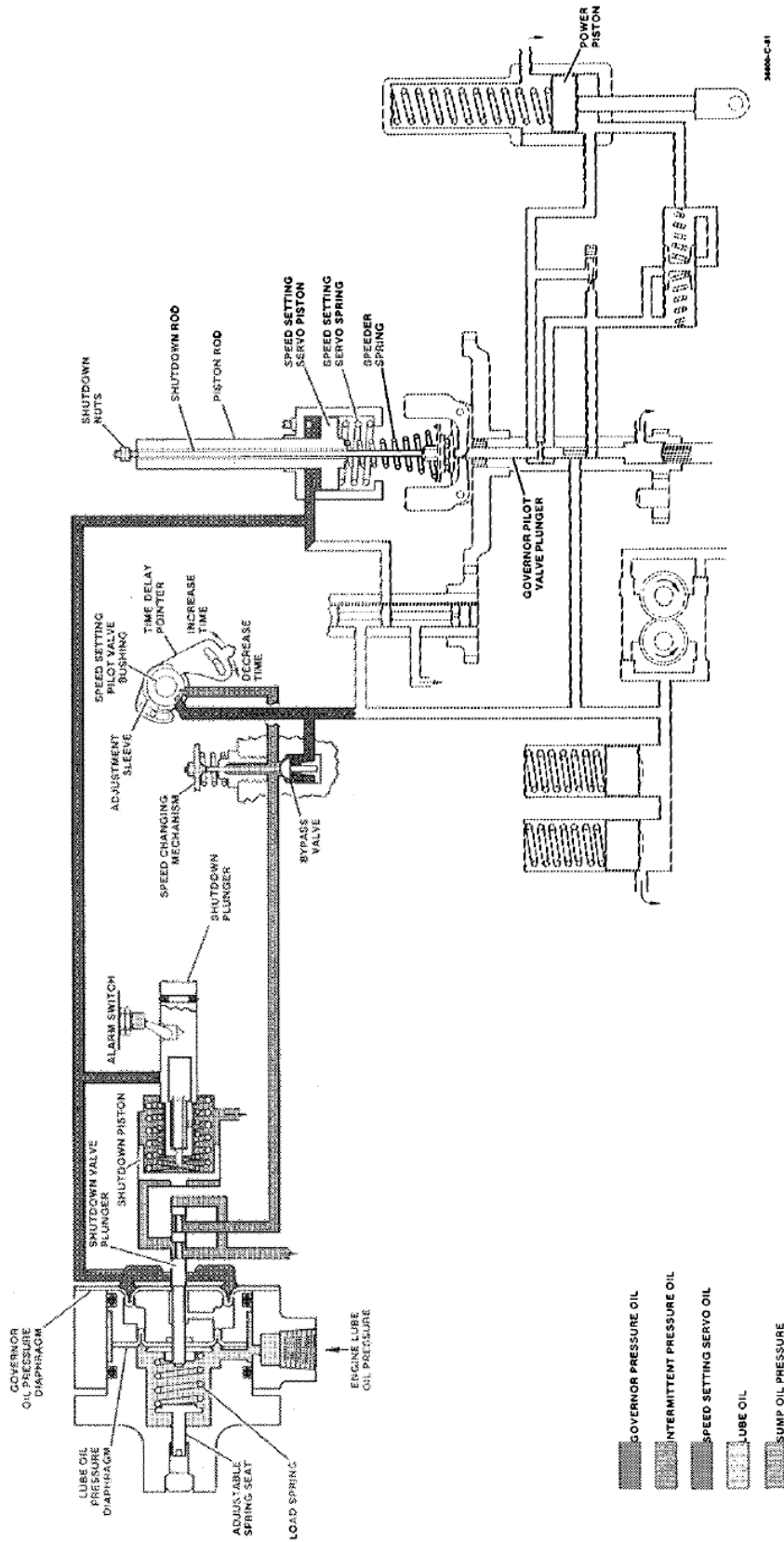

Figure 3-4. Lube Oil Pressure Shutdown and Alarm

When starting and at idle speeds, the bypass valve is closed and governor pressure oil travels through an intermittent-flow orifice in the rotating speed-setting-pilot-valve bushing. With each rotation of the bushing, a slot in the bushing registers with an oil-supply passage in the governor column and a hole in the adjustment sleeve. Thus, intermittent pressure oil is passed to the shutdown-valve plunger. The adjustment sleeve may be turned (by readjusting the time-delay pointer) so the cross-sectional area of the oil passage is increased or decreased. Thus, the volume of oil supplied with each rotation of the bushing is increased or decreased. Turning the pointer cw increases volume and decreases the time required to pass sufficient oil to initiate shutdown.

## Fuel Limiter

### General

The fuel limiter is an auxiliary system designed primarily for use on Woodward PG load control governors installed on turbo-supercharged locomotive engines. It is used with manifold air pressure as a reference. This governor is equipped with a load-control-overriding solenoid and provisions for fast unloading.

The function of the load control is independent of the fuel limiter. They are related only through an optional common reference to manifold air pressure. Figure 3-6a illustrates the basic fuel limiter, the load-control override and bias linkages installed on a locomotive governor equipped with load control, an overriding solenoid, and solenoid speed setting.

During acceleration, on turbo-supercharged engines, it is possible to supply more fuel to the engine than can be burned with the available air. This results from the normal lag of supercharger speed, and consequently manifold air pressure decreases with respect to engine speed.

The fuel limiter restricts the movement of the governor power piston toward the increase-fuel direction, limiting engine fuel during acceleration as a function of manifold air pressure (an approximation of the weight of air available at any instant). Fuel limiting improves the fuel-to-air ratio and, during acceleration, allows complete combustion. This improves acceleration and reduces smoke. Fuel limiting also protects the engine if the turbo-supercharger fails or reductions in engine air supply occur.

Figure 3-5 illustrates the unlimited, limited, and steady-state fuel schedules for a typical engine together with a typical acceleration transient from one steady-state condition to another.

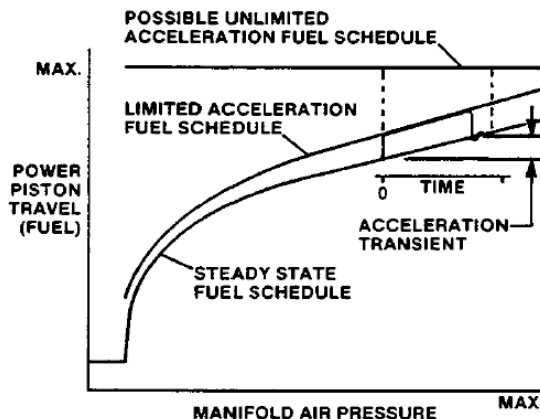

Figure 3-5. Typical Limited Acceleration Fuel Schedule Curve

## Description

The fuel limiter (Figure 3-6a) is essentially a floating lever, a bellcrank, a pressure sensor and cam, and a hydraulic amplifier together with a feedback lever and a fuel-limit lever. The right end of the floating lever is connected to the tailrod of the governor power piston and pivots about one leg of the bellcrank. The left end of the floating level rests on the right end of the hydraulic-amplifier feedback lever. The position of the bellcrank, and therefore the position of the floating-lever pivot point, is determined by the position of the fuel-limit cam. Raising the floating-lever pivot as manifold air pressure increases, allows the governor power piston to move upward a proportionally greater distance before fuel limiting occurs.

The pressure sensor is a force-balance device consisting of an inlet check valve, an orifice-pack restriction, a piston-and-cam assembly, a restoring spring, a bleed valve, and either a gauge-pressure or an absolute-pressure bellows arrangement. The sensor establishes a corresponding piston (and cam) position for each different manifold air pressure. The relationship between manifold air pressure and governor power-piston position (fuel flow) where limiting occurs is determined by the profile and angular tilt of the cam. Cam profiles are either linear or non-linear depending on engine and turbo-supercharger characteristics. The hydraulic amplifier is a pilot-operated, single-acting hydraulic cylinder. The amplifier provides the force necessary to overcome the resistance of the speeder spring, lift the shutdown rod and re-center the governor pilot-valve plunger when the fuel limit is reached for a given manifold air pressure.

## Operation

Pressured oil enters the fuel limiter through the inlet check valve. Oil is directed to the upper side of the sensor piston and through the orifice-pack restriction to the under side of the sensor piston. The inlet check valve prevents siphoning of the oil from the limiter housing during shutdown periods and omits the time lag to refill the orifice pack and piston cylinder. This prevents the sensor piston from going to maximum-fuel position during start-up. The bleed valve regulates the rate of oil flow from the area under the sensor piston to sump as a function of manifold air pressure. When the bleed valve bypasses a greater flow of oil from this area than is admitted through the orifice pack, the sensor piston moves downward. Conversely, reducing the bypass-oil flow to less than that admitted causes the sensor piston to rise. When the inflow and outflow of oil are equal, the piston remains stationary.

The sensing element of the absolute-pressure-type fuel limiter consists of two opposed, flexible, metallic bellows of equal effective area. The upper bellows is evacuated, and the lower bellows senses manifold air pressure. A spacer joins the bellows at the center while the outer end of each bellows is restrained to prevent movement. Manifold air pressure acting internally on the sensing bellows produces a force causing the spacer to move toward the evacuated bellows. The evacuated bellows provides an absolute reference, therefore, the sensing-bellows force is directly proportional to the absolute manifold-air pressure. Movement of the bellows spacer is transmitted through an output strap and a bleed-valve pin to the bleed-valve diaphragm.

The sensing element of the gauge-pressure-type fuel limiter consists of a single, flexible, metallic bellows. Movement of the gauge-pressure bellows is transmitted directly to the bleed-valve pin. The bellows force tends to open the bleed valve while the restoring-spring force tends to close the valve.

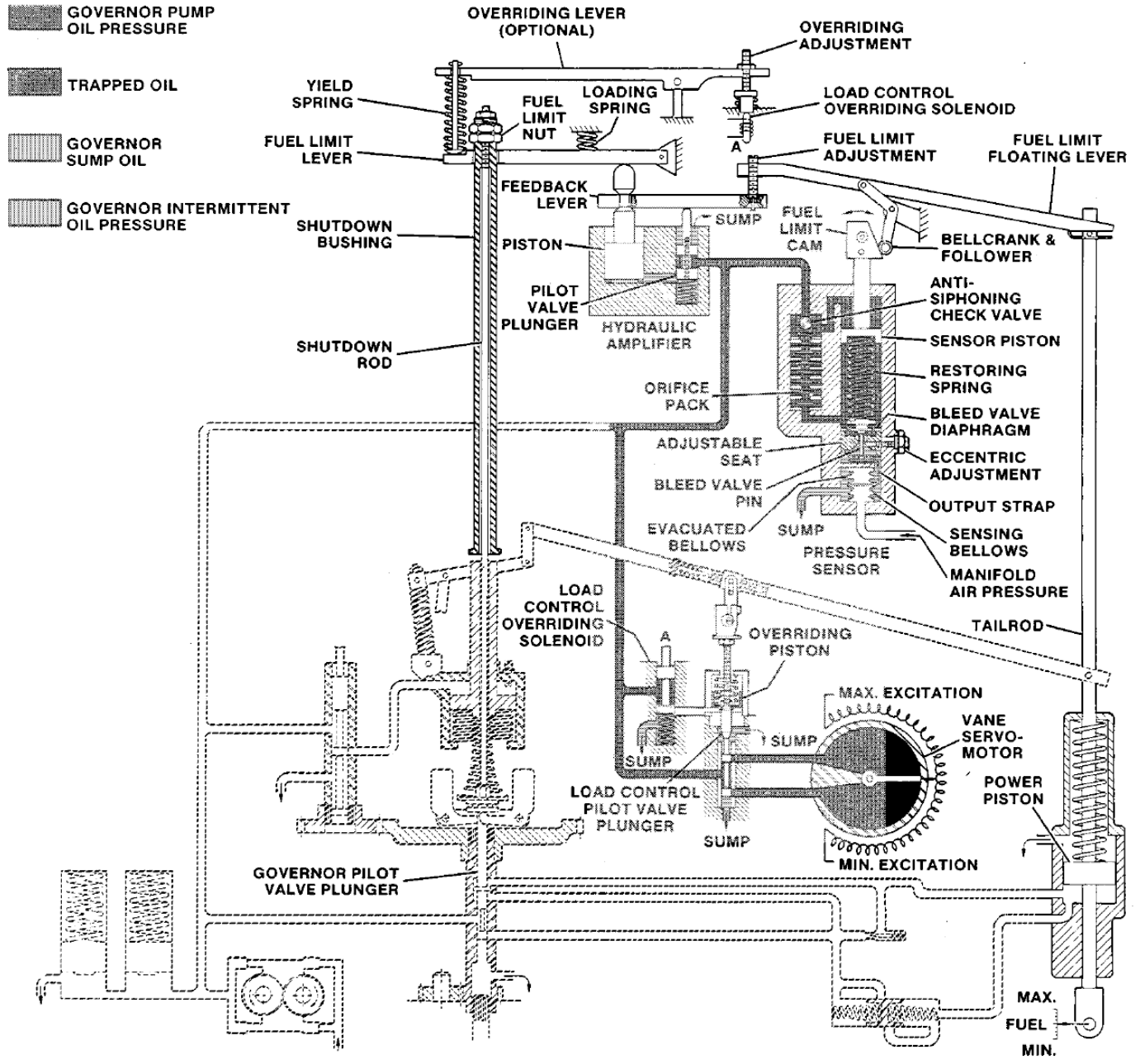

Figure 3-6a. Schematic Diagram, Fuel Limiter and Linkage

When these opposing forces balance, the bleed-valve diaphragm floats just off of its seat bypassing oil to sump. This rate of oil flow maintains a constant volume of oil in the area under the sensor piston.

Assume that the governor speed setting is advanced to a higher speed setting and a higher manifold-air pressure. The governor power piston moves upward supplying the additional fuel required for engine acceleration. Since manifold air pressure lags engine acceleration, the fuel-limiter cam and bellcrank initially remain stationary until manifold air pressure rises.

As the governor power piston moves upward increasing fuel, the fuel-limit floating lever pivots about the upper leg of the bellcrank and depresses the right end of the feedback lever on the hydraulic amplifier. This pushes the amplifier pilot-valve plunger below center, allowing pressured oil to flow into the area under the amplifier piston, causing the piston to rise. As the piston rises, it simultaneously lifts the left ends of both the fuel-limiter lever and the feedback lever.

When the fuel limit lever contacts the fuel-limit nut on the shutdown bushing, it begins lifting the shutdown rod to re-center the governor pilot-valve plunger. The upward movements of the fuel-limit and feedback levers continue until the left end of the feedback lever raises far enough to re-center the amplifier-pilot-valve plunger and stop the flow of oil to the amplifier piston. At this point, the fuel-limit lever re-centers the governor pilot-valve plunger, stopping the upward movement of the governor power piston. This limits the amount of fuel to provide a proper fuel/air ratio for efficient burning. Although the governor flyweights are in an underspeed condition at this time, the power piston remains stationary until manifold air pressure rises.

As engine speed and load increase, manifold air pressure rises after a short time lag. The increase in manifold air pressure produces a proportionate increase in the sensing-bellows force. The bellows force, now greater than the restoring-spring force, causes the bleed-valve diaphragm to move further off its seat. This allows a greater flow of oil to sump than is admitted through the orifice pack. Governor oil pressure acting on the upper side of the sensor piston forces the piston (and cam) downward and, in the process, further compresses the restoring spring. The piston continues its downward movement until the net increase in restoring-spring force equals the net increase in bellows force. This restores the bellows and bleed-valve diaphragm to their original positions. At this point, the outflow of oil is again equal to the inflow, and the piston stops moving.

As the sensor piston and cam move downward in response to a rise in manifold air pressure, the bellcrank rotates in a cw direction. This allows the floating-lever pivot point, the left end of the lever, and in turn the hydraulic-amplifier pilot-valve plunger to rise.

The loading spring under the pilot-valve plunger maintains a positive contact between the plunger, levers, bellcrank, and cam. When the pilot-valve plunger rises above center, the oil under the amplifier piston bleeds to sump through a drilled passage in the center of the plunger. The passage in the plunger restricts the rate of oil flow to sump and decreases the rate of movement of the amplifier piston to minimize hunting. As the amplifier piston moves downward, the left end of the fuel-limit lever also moves downward. This lowers the shutdown rod which in turn lowers the governor pilot-valve plunger and increases engine fuel.

The above events occur in continuous and rapid sequence. Normal governor operation is overridden during an acceleration transient and engine fuel is scheduled as a function of manifold air pressure, regardless of governor speed setting. To prevent interference with normal governing action during steady-state operation, the sensor piston and cam continue their downward movement until sufficiently below the effective limiting point.

Conversely, a drop in manifold air pressure rotates the bellcrank ccw. This lowers the fuel-limit lever, depressing the pilot-valve plunger, and releases pressured oil to the underside of the amplifier piston. The shutdown rod and governor pilot-valve plunger are raised, releasing oil from the power-piston cylinder to sump, and decreasing fuel to the engine. The left end of the fuel-limit floating lever pivots upwards releasing the hydraulic amplifier pilot-valve plunger upward. As the control land of the pilot-valve plunger opens the port from the piston cylinder, oil is bled to sump through a hole in the pilot-valve-plunger shaft. The shutdown rod is lowered, allowing the governor pilot-valve plunger to re-center.

## Load Control Override Linkage

The load-control-override linkage (Figure 3-6a) consists of an overriding lever which connects the left end of the fuel-limit lever to the load-control-overriding solenoid through a pin-and-yield spring combination. The overriding solenoid adjustment set screw must be adjusted to fully depress the overriding-solenoid plunger completely, at a point just before the fuel-limit lever contacts the fuel limit nut. Pressured oil is released to the underside of the overriding piston, lifting the load-control pilot-valve plunger in the decrease-load direction. During acceleration transients, when fuel limiting occurs, the integral-vane servomotor begins to unload prior to an acceleration lag, reducing overload and poor acceleration. Depending on engine and turbo supercharger characteristics, premature unloading can permit the engine to accelerate quickly and raise the manifold air pressure rapidly enough to prevent any fuel limiting from taking place.



### NOTE

**On this governor application, load on the engine is adjusted through a servomotor-operated rheostat in the field excitation circuit of a generator. The servomotor, in turn, is controlled through the governor's load-control system.**

As engine speed nears the new setting, and manifold air pressure rises, a downward movement of the fuel-limit lever permits the overriding-solenoid plunger to rise. Oil is released from under the load-control-overriding piston to sump, lowering the load-control pilot-valve plunger. The load-control pilot-valve plunger moves down, releasing pressured oil to the vane servomotor, and increases excitation. This increases load in proportion to the increase in engine speed.

## LVDT Load Control System

The secondary purpose of the governor is to maintain a definite horsepower output of the engine for a specific speed setting of the governor. To achieve this objective, the LVDT (Linear Variable Differential Transformer), adjusts (through external circuitry) the generator field excitation current to keep the traction motor load at a set point.

The LVDT provides a linear output voltage over a displacement measuring range of 1.000 inch (25.40 mm). It consists of a primary coil and two separate secondary windings of enameled copper wire wound on a common cylindrical, resin bonded, glass fiber core. A ferromagnetic stainless-steel case houses the coil assembly and provides full electromagnetic and electrostatic shielding. All internal voids are filled with epoxy resin. The spring-loaded captive core is manufactured from nickel iron alloy and moves freely in its guides. The device requires an excitation of 6 Vac (RMS) at 2.5 KHz. The device has a resolution of 25 mV per 0.001 inch (0.03 mm) displacement.

The excitation voltage is applied to the primary winding. The two secondary windings are wound in opposite directions to each other. When the movable core is centered, the secondary voltages are equal in amplitude, but opposite in phase. At other core positions the secondary voltages will still be opposite in phase but no longer equal in amplitude. The amount of amplitude difference is proportional to the distance of the core from center.

A rectifier assembly connected to the secondary windings of the LVDT converts the secondaries' ac voltages to a dc voltage. The amplitude of the dc voltage is proportional to core distance from center and the polarity of the dc indicates the core direction from center. The rectified dc voltage has a resolution of 10 mV per inch (0.39 mV/mm).

The LVDT core center position depends on the governor speed setting. The core is positioned by a plunger which senses engine load and governor speed setting. A change in engine load (horsepower) moves the core from center position. When the engine load increases, the LVDT core moves to cause a decrease in generator excitation voltage to decrease load. Since the load is reduced, the governor decreases fuel and, at the same time, the LVDT core position. This continues until the engine speed is that called for by the governor speed setting and the LVDT core is once again centered.

The horsepower is now at the designed value for the present speed setting. The governor has responded to an increase in load without a long term change in speed. When engine load decreases the response is similar, but in opposite directions.

## Start Fuel Limiter

The Starting Fuel Limiter minimizes the tendency of engines to flood when starting and minimizes excessive smoking during engine cranking. The starting fuel-limiter linkage consists of a fuel limit lever, an adjustable limit screw, and a lever spring. Figure 3-6b shows the limiter linkage arrangement.

The limit lever extends over the floating lever between the speed-setting servo piston and the power piston tailrod. The tailrod is positioned as a function of the fuel setting. The speed-setting servo piston is positioned as a function of speed setting. When the tailrod moves up (as fuel increases) sufficiently far, the floating lever lifts the free end of the fuel limit lever. The lever spring continually urges the limit lever down in the direction to contact the floating lever.

The adjustable limit screw attaches to a lug in the fuel-limit lever. The head of the limit screw fits under the shutdown nuts. The limit screw is adjusted so that the shutdown nuts (and shutdown rod) are lifted as the tailrod reaches the point corresponding to the desired maximum starting fuel. Lifting the shutdown nuts and shutdown rod prevents the governor from increasing fuel further.

When the governor speed setting is increased, the speed setting servo position moves down. This action moves the floating lever down away from the fuel limit lever so that the limit level no longer restricts fuel.

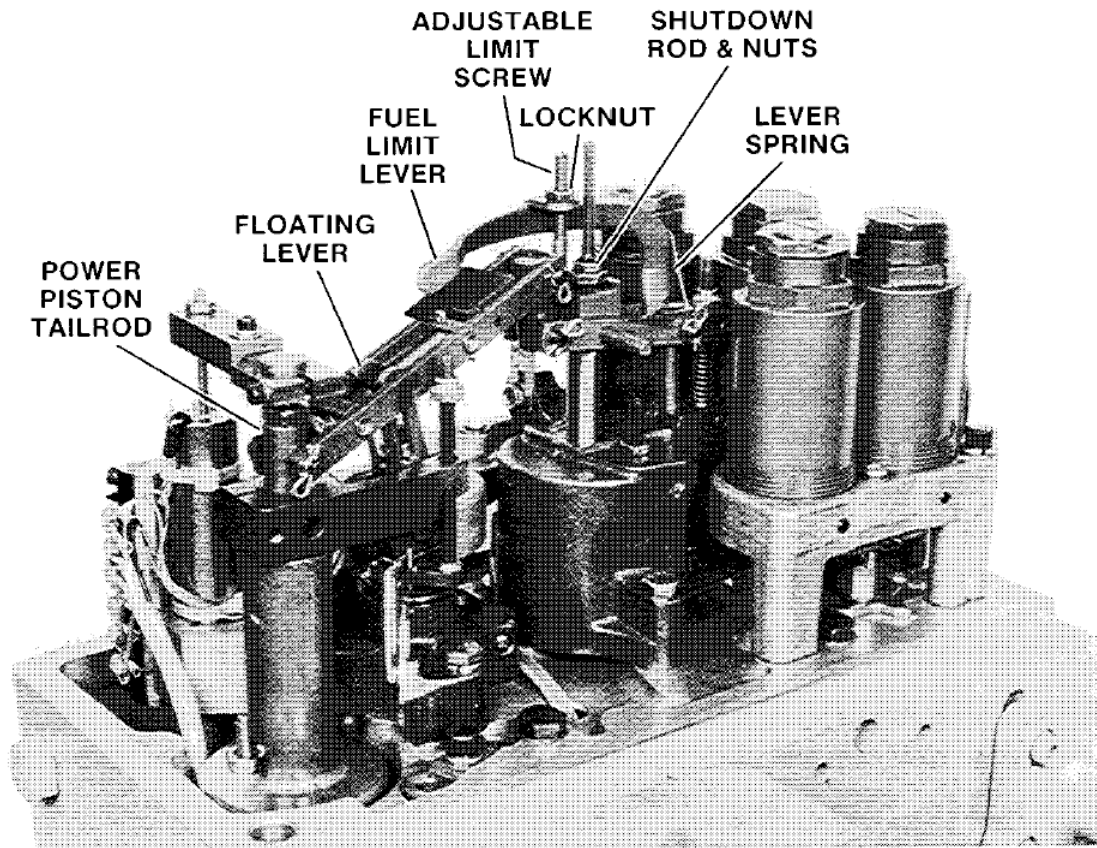

Figure 3-6b. Start Fuel Limiter Linkage

# Chapter 4.

## Troubleshooting

### Introduction

It is impossible to anticipate every kind of trouble that is encountered in the field. This covers the most common troubles experienced. Poor governing may be due to faulty governor performance, or it may be due to the governor attempting to correct for faulty operation of the engine or turbine auxiliary equipment. The effect of any auxiliary equipment on the overall control requirements of the governor also must be considered.



#### **WARNING—START-UP**

**Be prepared to make an emergency shutdown when starting the engine, turbine, or other type of prime mover, to protect against runaway or overspeed with possible personal injury, loss of life, or property damage.**

### Oil

Fill the governor with oil to the mark on the oil level gauge with the engine idling. Oil must be visible in the glass on the gauge during all other conditions.

Dirty oil causes approximately 50 per cent of all governor troubles. Use clean new or filtered oil. Containers used to fill governors from bulk containers should be perfectly clean. Oil contaminated with water breaks down rapidly, causes foaming and corrodes internal governor parts.

### Compensating Needle Valve

The compensating needle valve must be correctly adjusted with the governor controlling the engine or turbine, even though the compensation may have been previously adjusted at the factory or on governor test equipment. Although the governor may appear to be operating satisfactorily because the unit runs at constant speed without load, the governor still may not be correctly adjusted.

High overspeeds and low underspeeds, or slow return to speed, after a load change or speed-setting change, are some of the results of an incorrect setting of the compensating needle valve.

### Definitions

Use the chart on the following pages to determine the probable causes of faulty operation, and to correct these troubles. Terms used in the chart are defined as follows:

**Hunt**—A rhythmic variation of speed which can be eliminated by blocking governor operation manually, but which will recur when the engine is returned to governor control.

**Surge**—A rhythmic variation of speed, always of large magnitude, which can be eliminated by blocking governor action manually and which will not recur when the engine is returned to governor control, unless speed adjustment is changed or the load changes.

**Jiggle**—A high-frequency vibration of the governor fuel-rod end (or terminal shaft) and fuel linkage. Do not confuse this with normal controlling action of the governor.

## Preliminary Inspection

Governor troubles are usually revealed in speed variations of the prime mover, but it does not necessarily follow that such variations are caused by the governor. When improper speed variations appear, the following procedure should be performed.

1. Check the load to be sure the speed changes are not the result of malfunctions in the vane servo, generator control circuits, switchgear, etc.
2. Check engine operation to be sure all cylinders are firing properly and that the fuel injectors are in good operating condition and properly calibrated.
3. Check linkage between governor and fuel racks to be sure there is no binding or excessive backlash.
4. Check setting of governor compensation needle valve.
5. Check speed-setting circuits for voltage level and sequencing.
6. Check for fuel-pressure changes.
7. Check governor oil pressure. A test port is provided in two sides of the governor power case for this purpose.
8. The source of most troubles in any hydraulic governor stems from dirty oil. Grit and other impurities can be introduced into the governor with the oil, or can form when the oil begins to break down (oxidize) or become sludgy. The internal moving parts are continually lubricated by the oil within the unit. Valves, pistons, and plungers will stick and even "freeze" in their bores, due to excessive wear caused by grit and impurities in the oil. If this is the case, erratic operation and poor response can be corrected by flushing the unit with fuel oil or kerosene. The use of commercial solvents is not recommended as they may damage seals or gaskets.

Change the oil and flush the governor twice a year if possible. Remove the cover, open the drain cock and drain out the oil. Flush the governor by filling it with fuel oil. With the engine running at low speed, cycle the governor by opening the needle valve two or three turns. Let the governor hunt for a minute or two and then stop engine and drain the governor. Flush the governor once again. Fill the governor with oil, pouring it over all the internal parts that are visible. Start the engine and reset the compensation needle valve.

9. Check drive to governor for any evidence of misalignment, roughness, excessive backlash, etc.

Table 4-1. Troubleshooting

Trouble	Cause	Correction
1. Engine hunts or surges.	Needle valve adjustment incorrect.	Adjust needle valve as described in Chapter 2.
	Buffer springs too light. This may occur on a new installation; or on an old installation because of a radical change in load conditions.	Install heavier buffer springs (consult Woodward Governor Company).
	Lost motion in engine linkage, fuel pumps, or gas valve.	Repair linkage, fuel pumps, or gas valve.
	Binding in engine linkage, fuel pumps, or gas valve.	Repair and re-align linkage, fuel pumps, or gas valve.
	Governor stroke too short. This may occur on a new installation. Should be at least 50 percent of full governor travel between idle and full load.	Redesign or rework the fuel linkage to require more governor stroke. (Consult engine manufacturer and Woodward Governor Company).
	Low oil level. No harm will be done if top of oil is visible in gauge glass.	Add oil slowly to correct level in gauge.
	Dirty oil or foaming oil in governor.	Drain governor oil; flush governor to clean, and refill with proper clean oil. Bleed air and adjust the needle valve.
	Governor worn or not correctly adjusted.	Try spare governor or repair and adjust governor. <ul style="list-style-type: none"> <li>a. Check flyweight pins and bearings for wear.</li> <li>b. Check flyweight toes for wear and/or flat spots.</li> <li>c. Check flyweight and head thrust bearing; also centering bearing.</li> <li>d. Pilot-valve plunger may be sticking; clean and polish if necessary.</li> </ul> <p style="text-align: center;"><b>CAUTION—CONTROL LAND CARE</b> <b>Do not break corners of control land.</b></p> <ul style="list-style-type: none"> <li>e. Check vertical adjustment of pilot valve plunger and correct if necessary.</li> <li>f. Clean and polish all moving parts to ensure smooth and free operation.</li> </ul>
Spring too weak in telescopic link.	Install heavier spring so that link stays solid at all times.	
2. Fuel pump racks do not open quickly when cranking engine.	Low oil pressure in governor.	<ul style="list-style-type: none"> <li>a. Check governor pump gears and gear pockets for excessive wear. No correction except to replace worn parts.</li> <li>b. Flush governor and refill with clean oil to remove dirt in pump check valves.</li> <li>c. Examine pump check valves. If not seating tightly, install new ones.</li> </ul>
	Cranking speed too low.	Install a booster servomotor (consult Woodward Governor Company).
	Booster servomotor (if used) not functioning properly.	<ul style="list-style-type: none"> <li>a. Check action of automatic air-starting valve.</li> <li>b. Check air and oil connections.</li> </ul>
	Shutdown nuts not adjusted correctly.	Loosen nuts and start engine. Readjust nuts for proper clearance at idle.

Trouble	Cause	Correction
3. Jiggle at governor rod end or at terminal shaft.	Rough engine drive.	Inspect drive mechanism: a. Check alignment of gears. b. Inspect for rough gear teeth, eccentric gears, or excessive backlash in gear train. c. Check gear keys and nuts or set screws holding drive gears to shafts. d. Tighten chain between crankshaft and camshaft (if used). e. Check engine vibration dampener (if used). f. If governor has serrated drive shaft, check for wear of shaft and serrated coupling.
	Failure of flexible drive in fly-weight head.	Remove, disassemble, and clean fly-weight head parts.  Check spring and install new spring coupling assembly if necessary. Center the coupling for equal travel in opposite directions.
	Governor not bolted down evenly on engine mounting pad.	Loosen screws, disconnect the fuel linkage, and turn the governor 45° cw and ccw on its mounting pad a few times. Tighten screws.
4. Engine is slow to recover from a speed deviation resulting from a change in load or slow to respond to a change in speed setting.	Incorrect buffer springs in governor.	Install correct buffer springs (consult Woodward Governor Company).
	Governor oil pressure is low.	See item 2 of this table.
	Fuel supply restricted.	Clean fuel filters and fuel supply lines.
	Engine may be overloaded.	Reduce the load.
	Supercharger does not come to new speed quickly to supply sufficient air to burn the added fuel.	No simple field correction. Consult engine manufacturer and Woodward Governor Company or overhaul supercharger.
5. Engine does not pick up rated full load.	Fuel racks do not open far enough.	a. Check fuel-pump stops and adjust as necessary. b. Check linkage between governor and fuel pumps and adjust if necessary. c. Oil pressure maybe too low. See item 2 of this table.
	Supercharger does not supply sufficient air.	Overhaul supercharger.
6. Engine overspeeds on starting.	Governor too slow.	Adjust needle valve for highest opening. Install lighter buffer springs, if possible.
	Speed setting too high.	Decrease starting-speed setting.
	Governor admits too much fuel for starting.	a. Limit travel of booster servomotor. b. Readjust speed setting or manifold pressure torque limiter (consult engine manufacturer).
	Compensation bypass retarded.	Install short buffer piston.
7. Engine stalls on deceleration to minimum speed.	Governor too slow.	Adjust needle valve for maximum opening. Install lighter buffer spring. Try shorter buffer spring.
	Minimum speed too low.	Raise minimum speed.
	Compensation not being cut off at idle.	Consult Woodward Governor Company to check how governor is built.

Trouble	Cause	Correction
8. Hard starting and/or excessive smoke for a short duration during starting after a relatively long shutdown period.	The fuel limiter's anti-siphoning check valve leaking--sensor piston goes to maximum-fuel position at start-up and then returns to minimum-fuel position as housing refills with oil.	Replace check valve.
9. Excessive smoke during acceleration.	Fuel-limiter orifice pack clogged--sensor piston goes to and remains at maximum fuel position.	Drain governor oil, flush with fuel oil or kerosene. Refill with clean oil. Operate for a short time. Then drain and refill. If necessary, remove fuel limiter orifice pack, disassemble, and clean.
	Fuel limiter not adjusted correctly.	Adjust as instructed in Chapter 6.
	Restoring spring fatigued or broken.	Replace restoring spring.
10. Engine bogs during acceleration.	Load control override linkage improperly adjusted.	Adjust as instructed in Chapter 6.
11. Erratic operation.	Contaminated or foamy oil. Sludge formation.	Drain governor oil; flush with fuel oil or kerosene. Refill with clean oil; operate for a short time, drain, and refill. If necessary, remove fuel limiter, disassemble, and clean.
	Low governor oil level--air entrapment.	Add oil to correct level as indicated on sight gauge glass. Check for leakage, particularly at the governor drive shaft oil seal. Check manifold air pressure line for presence of oil which would indicate leakage at the fuel-limiter bellows.
	Leakage in manifold air pressure lines or fittings.	Repair leaks.
	Fuel-limiter bellows leaking.	Replace bellows.
12. Deadband at low or high end of fuel-limiting schedule.	Fuel-limiter-sensor piston travel not properly calibrated within manifold air-pressure range.	Adjust as instructed in Chapter 6.

Fuel limiter troubles such as erratic operation or slow response to changes in manifold air pressure are usually the result of oil contamination. Correct this type of trouble by flushing the governor with fuel oil or kerosene.



**CAUTION—SOLVENTS**

To prevent damage to oil seals or gaskets, DO NOT use non-petroleum-base solvents.

# Chapter 5. Maintenance

## Introduction

This chapter describes maintenance which includes instructions for disassembly, cleaning, inspection, repair, and assembly.

## Special Tools

Refer to manual 36405 for a listing of special tools required for maintenance or overhaul.

## General Instructions



### **CAUTION—CARE OF GOVERNOR**

**Use care in handling the governor to avoid damage to the drive shaft, oil seal, bearing and other internal parts or surfaces. Place the governor on supporting blocks and do not strike the drive shaft.**

1. Drain oil, if any, from governor.
2. Clean exterior surfaces using a cloth moistened with cleaning solvent.
3. Do not remove or disturb the position of screws, brackets, etc., which function as adjustments; nor disassemble the various linkages further than required to effect removal unless replacement of component parts is necessary.
4. Do not remove press-fit parts such as bearings, locating (dowel) pins, oil pump check valves, pivot pins, etc., unless replacement is necessary or removal is required to effect disassembly or removal of other parts.
5. Discard, do not reuse gaskets, preformed packings (O-rings), oil seals, copper sealing washers, retaining rings, cotter pins, roll or spirol pins, etc., removed in the process of disassembly.

## Disassembly

Place the governor on some type of stand to protect the drive shaft and hold the governor in position to be worked on.

1. Remove cover (2 screws).
2. If overriding solenoid (ORS) bracket is present, remove it. (Figure 5-1).
3. Remove solenoid pack (Figure 5-2).
  - a. Disconnect wires from terminal block.
  - b. Remove three screws that secure the solenoid pack to the column.
  - c. Lift off solenoid pack.

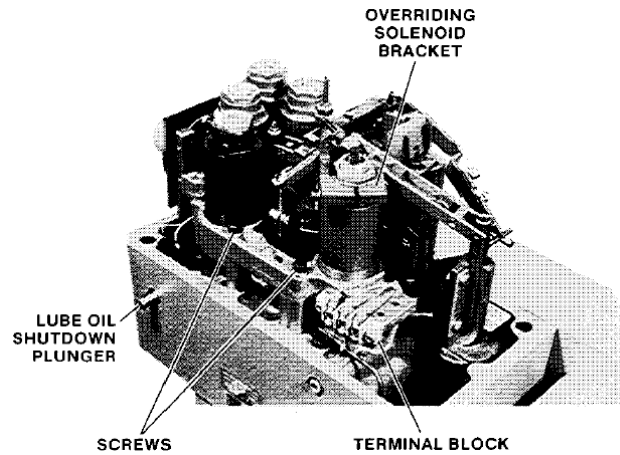

Figure 5-1. PGEV with Fuel Limiter

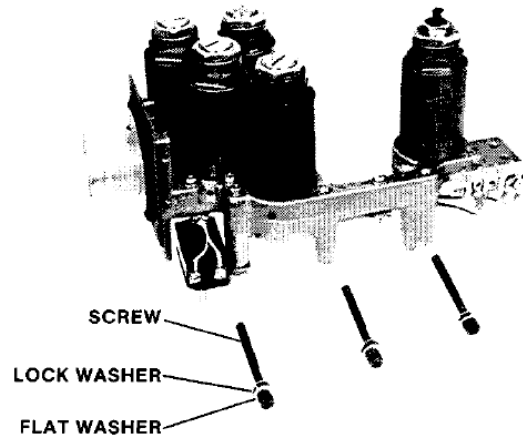

Figure 5-2. Solenoid Pack

4. Remove fuel limiter (Figure 5-3).
  - a. Remove shutdown nut, limiter nuts, and bushing.
  - b. Remove loading spring.
  - c. Remove 2 screws.
  - d. Disconnect load-control floating lever from tailrod.
  - e. Disconnect load-control floating lever from load-control link.
  - f. Disconnect air connection coupling.
  - g. Lift off the fuel-limiter assembly (Figure 5-4).
  - h. Lift out the overriding solenoid spring (ORS) and piston (Figure 5-5).
  - i. Lift out the load-control bushing, spring, and gasket (Figure 5-6).

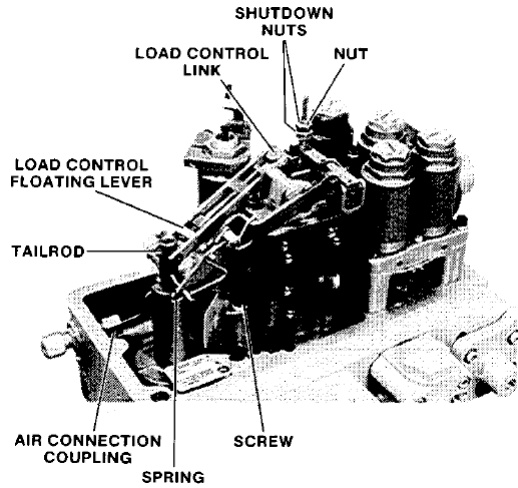

Figure 5-3. Fuel Limiter Installed

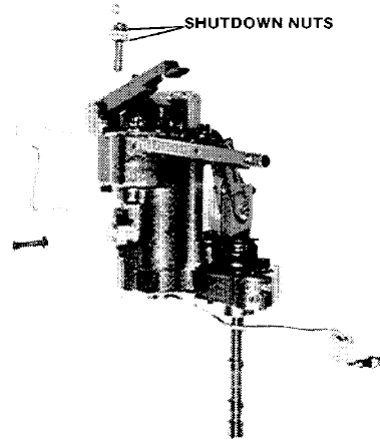

Figure 5-4. Fuel Limiter Assembly



Figure 5-5. Overriding Solenoid Spring and Piston



Figure 5-6. Load Control Bushing, Spring, and Gasket

5. Remove triangular plate and speed-setting cylinder (Figure 5-7).
  - a. Remove 2 screws.
  - b. Remove pin that connects restoring link to restoring lever.
  - c. Lift off speed-setting cylinder and spring (Figure 5-8).

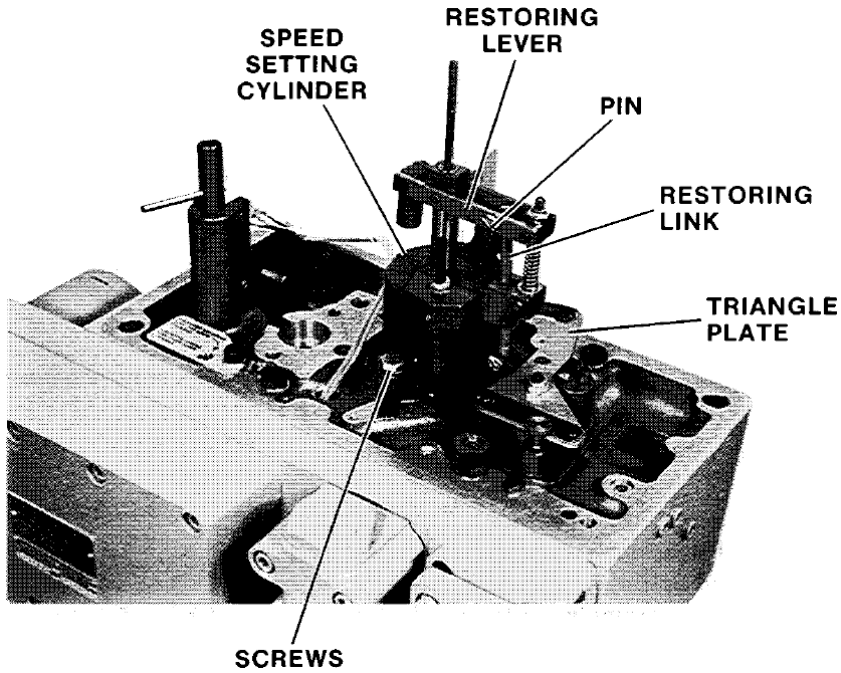

Figure 5-7. Triangular Plate and Speed Setting Cylinder Installed on Column

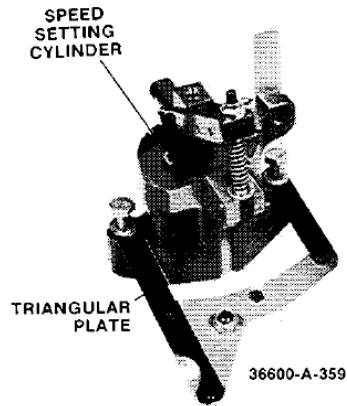

Figure 5-8. Speed Setting Cylinder and Triangular Plate

6. Remove 2 screws and lift off time delay mechanism (Figures 5-9 and 5-10).

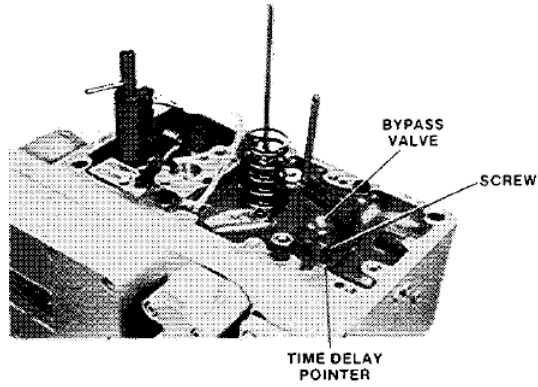

Figure 5-9. Time Delay Mechanism Installed

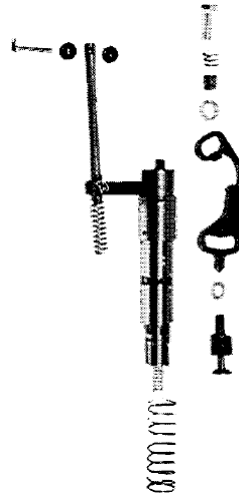

Figure 5-10. Time Delay Mechanism and Speed Setting Pilot Valve Assembly

7. Lift out speed setting plunger, bushing, floating lever, and load spring (Figure 5-10).
8. Remove the bypass valve (Figure 5-9 and 5-11).



Figure 5-11. Bypass Valve

- 9. Remove side plate cover, 12 screws (Figure 5-12).

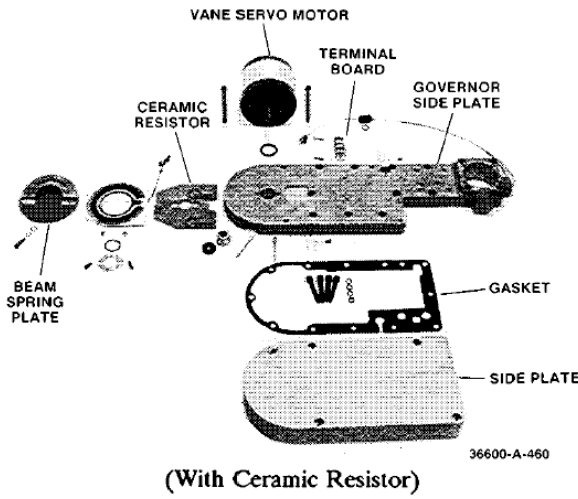
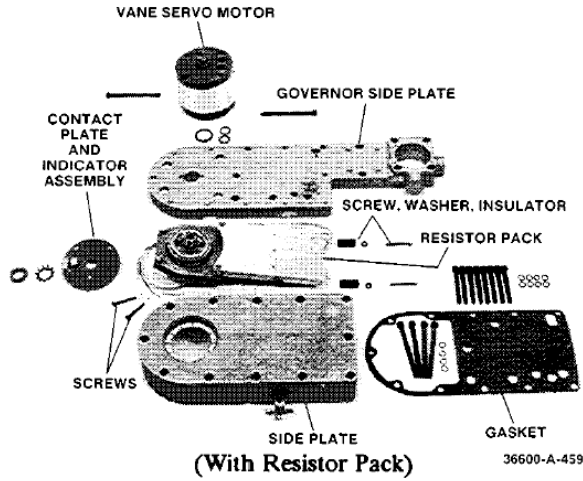

Figure 5-12. Vane Servo

- 10. Remove vane servo (Figures 5-13 and 5-14).

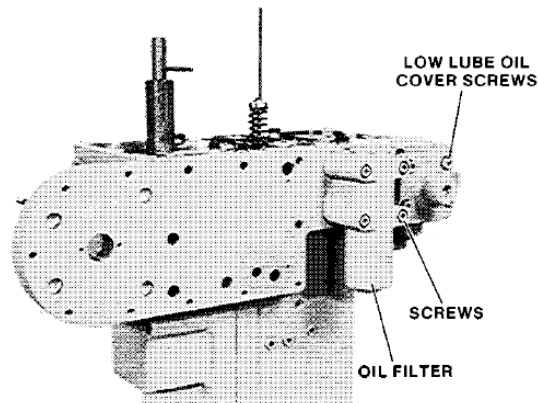

Figure 5-13. Vane Servo and Oil Filter

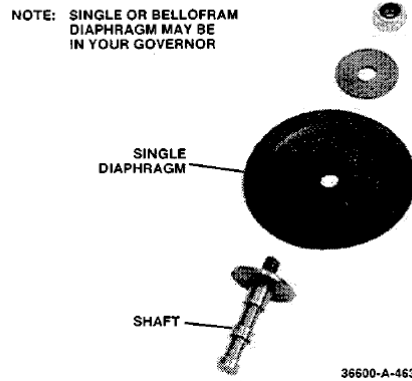
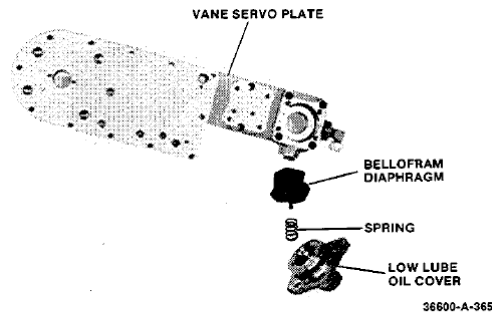

Figure 5-14. Low Lube Oil Cover and Diaphragm

11. Remove snap ring and lift out contact plate and indicator assembly (Figure 5-12).
12. Remove 2 screws under contact plate and 2 screws and spacers from end of resistor pack and remove resistor pack (Figure 5-12).
13. Remove 4 screws and oil filter (Figure 5-13).
14. remove low-lube-oil cover, spring, gasket, and diaphragm (Figures 5-13 and 5-14).

**NOTE**

If cover will not come off, remove adjustment screw from center of cover.

**CAUTION—BELLOFRAM**

Be careful to not damage bellofram (diaphragm) when removing it.

15. Remove side plate and gasket, along with pressure-reducing valve sleeve, plunger, and spring from the column (Figure 5-15).

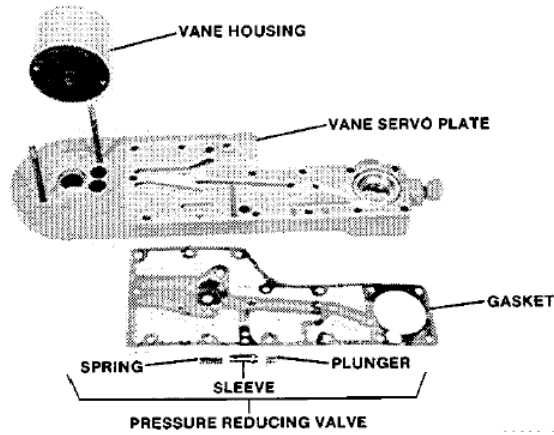

Figure 5-15. Side Plate

16. Remove low-lube-oil valve bushing, piston, spring, and gasket (Figure 5-16).

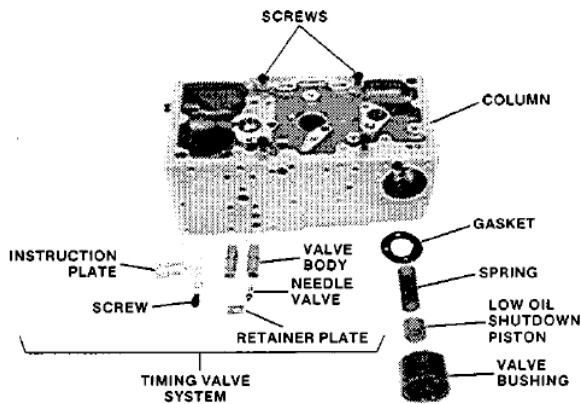

Figure 5-16. Low Lube Oil and Timing Valve Systems

- 17. Remove screw and plates and lift out two timing valves.
- 18. Remove 4 screws. If water box is present, disconnect both tubes from column. Then separate column from power case (Figure 5-16).
- 19. Lift ballhead assembly out of power case (Figure 5-17).

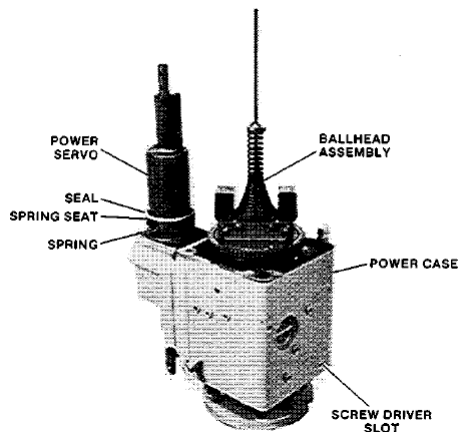

Figure 5-17. Power Case and Power Servo

20. Remove spring, spring seat, and seal (Figure 5-17).
21. Remove 4 screws. Remove 2 screws and water box from power case. Then separate power servo from power case.
22. Remove spring seat and spring from power servo side of the power case (Figure 5-18).

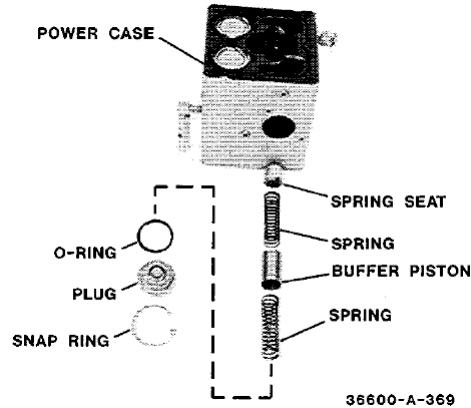

Figure 5-18. Compensation System

23. Remove snap ring, plug, O-ring, spring, and buffer piston (Figure 5-18).
24. Turn power case upside down, remove 8 screws and lift off base (Figure 5-17).

**NOTE**

If base does not separate easily from power case, use a screw driver in slots to pry apart.

25. Remove 3 screws and retainer plate. Lift out drive shaft seal and gasket (Figure 5-19).

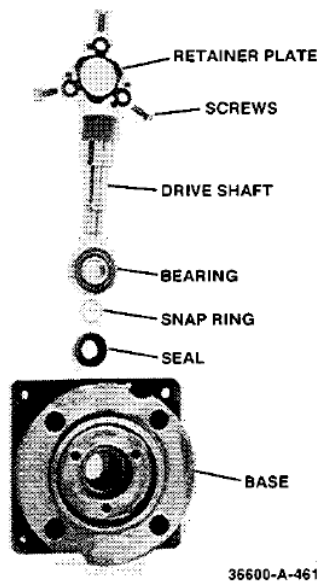

Figure 5-19. Drive Shaft

26. Remove drive gear and idler gear from power case (Figure 5-20).

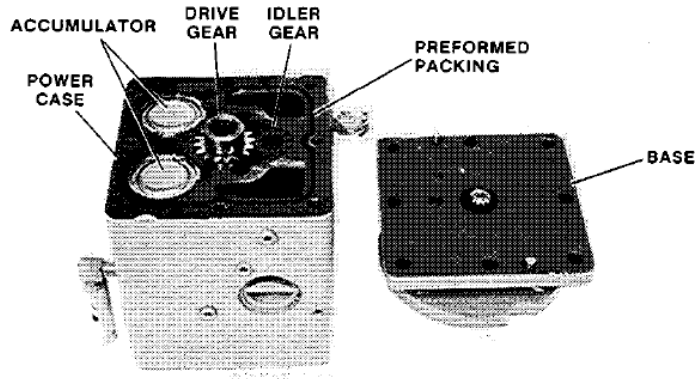

Figure 5-20. Power Case and Base

27. Ballhead disassembly (Figure 5-21).

- a. Turn speeder spring, and remove spring and check plug from spring seat.
- b. Loosen PVP (pilot-valve plunger) nut and remove the shutdown rod.
- c. Lift off spring seat, thrust bearing, washer, and adjusting spring.
- d. Remove 4 pins and flyweights.
- e. Remove screw and spring coupling.
- f. Remove 8 screws and flyweight head.
- g. Take out O-ring and bearing.
- h. Remove snap ring, bushing, and pilot-valve plunger.



**WARNING—SPRING DANGER**

You can be injured by accumulator springs because they are under compression. Use an arbor press and be careful when removing them.

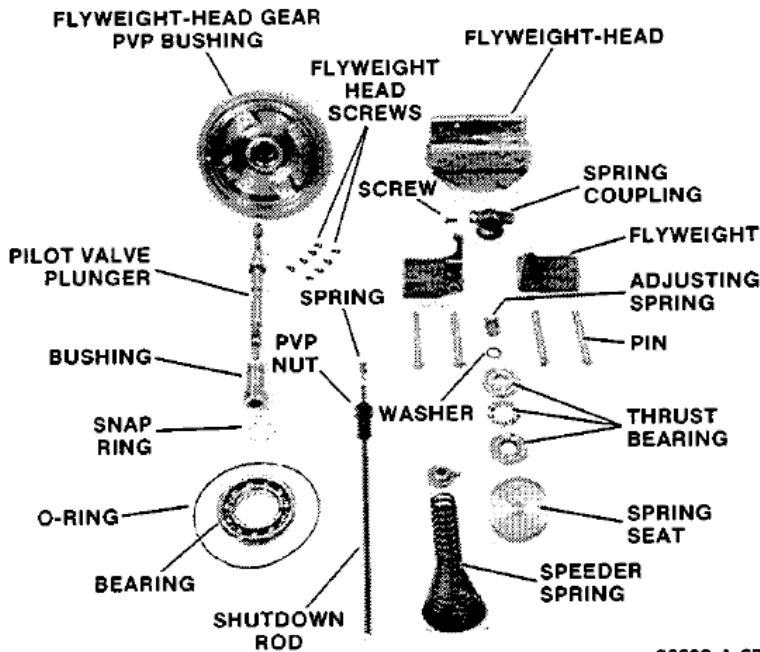

36600-A-372

Figure 5-21. Ballhead Assembly

28. Power Case Disassembly
  - a. Use an arbor press to hold the spring and remove the snap ring. Slowly release the compressed accumulator spring and spring seat (Figure 5-22).
  - b. Remove oil gauge.
  - c. Remove all plugs.
  - d. Remove drain.

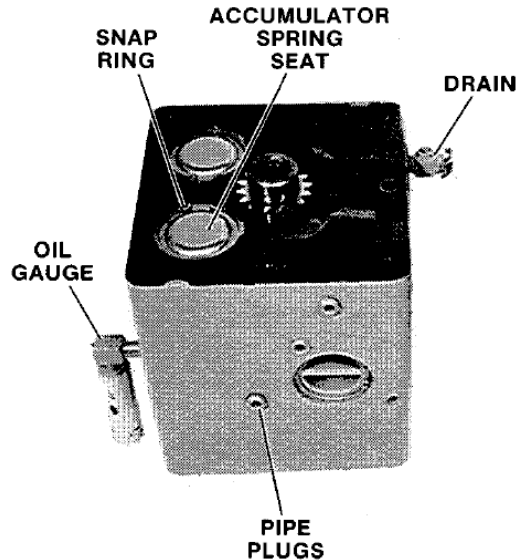

Figure 5-22. Power Case

29. Solenoid Pack Disassembly (Figures 5-23 and 5-24).
  - a. Disconnect wires and remove switch from receiver assembly.
  - b. Remove nut from solenoid.
  - c. Screw plunger stop out of case.
  - d. Screw case out of receiver assembly.
  - e. Remove load spring, insulator, and plunger.
  - f. Remove soldered wires from solenoid coil.
  - g. Remove guide, bushings, and shield washers.
  - h. Disassemble all solenoids.

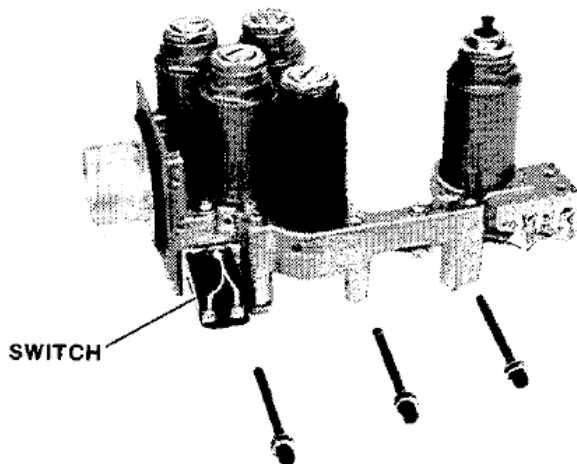

Figure 5-23. Solenoid Pack and Receiver

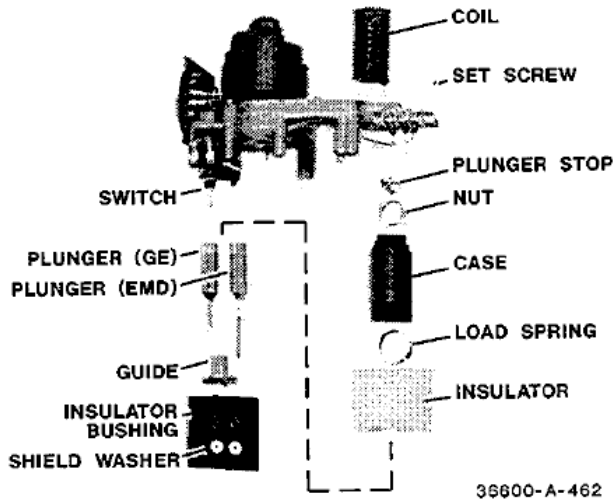

Figure 5-24. Solenoid and Receiver Assembly

## 30. Speed-Setting Cylinder Disassembly (Figure 5-25).

- a. Remove nut and pin from fulcrum screw.
- b. Remove headed pin and separate restoring lever into 2 pieces.
- c. Press piston rod out of fulcrum block, being careful not to drop piston.
- d. Remove stop screw.

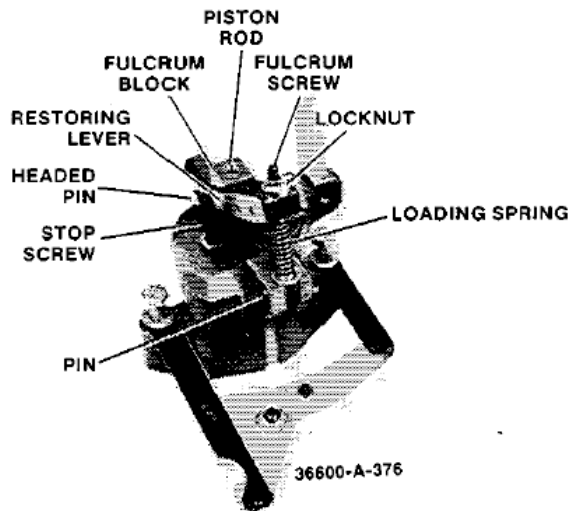

Figure 5-25. Speed Setting Cylinder

## 31. Fuel-Limiter Disassembly.

- a. Remove snap ring and lift out pivot and adjusting screw (Figure 5-26).
- b. Take out loading spring.
- c. Remove cotter pin, fuel-limit-lever pivot pin and fuel-limit lever.
- d. Remove feedback lever.
- e. Remove screws (2 on top and 1 from bottom) and lift off bracket.
- f. Remove cotter pins from top of bellcrank and remove bellcrank.
- g. Remove pin from bellcrank.
- h. Remove cotter pin, pin, and bearing from bellcrank.
- i. Lift out amplifier piston, pilot-valve plunger and load spring.
- j. Lift out sensor piston sleeve, piston and fuel limit cam assembly.

**NOTE**

Do not separate cam from piston unless cam is damaged or worn.

- k. Lift out spring and seats, and bleed valve.
- l. Remove 2 Nylok screws and take out bellows, spacer, and valve seat.
- m. Remove eccentric.
- n. Remove O-ring, screen, O-ring, and check-valve.
- o. Remove snap ring, washers, gaskets, orifice plates, and spring from the orifice body.

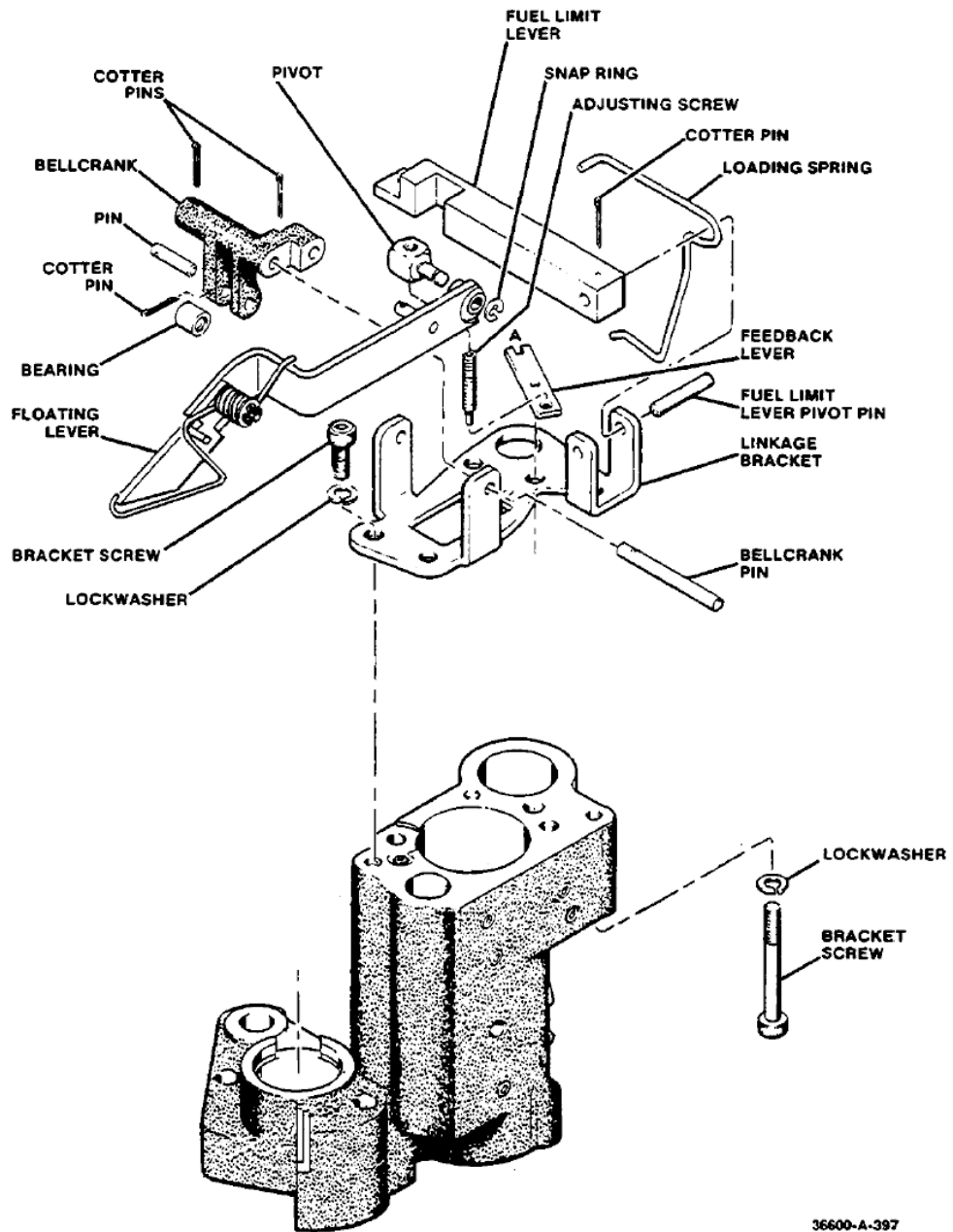

Figure 5-26. Fuel Limit Bracket and Linkage

32. Power servo disassembly (Figure 7-5 or 7-6).



**WARNING—SPRING DANGER**

The linear output power servo is spring loaded. Use some type of press or jack screws when disassembling the servo.

See Figure 7-5 for Linear Output Servo.

- a. Remove spring, seal ring, and seal.
- b. Use jack screws and some type of press to hold spring guard while loosening screws.
- c. Remove pin and separate rod end from piston.
- d. Remove 2 seals.

See Figure 7-6 for Rotary Output Servo Disassembly.

33. Water Box disassembly.

See Figure 5-69.

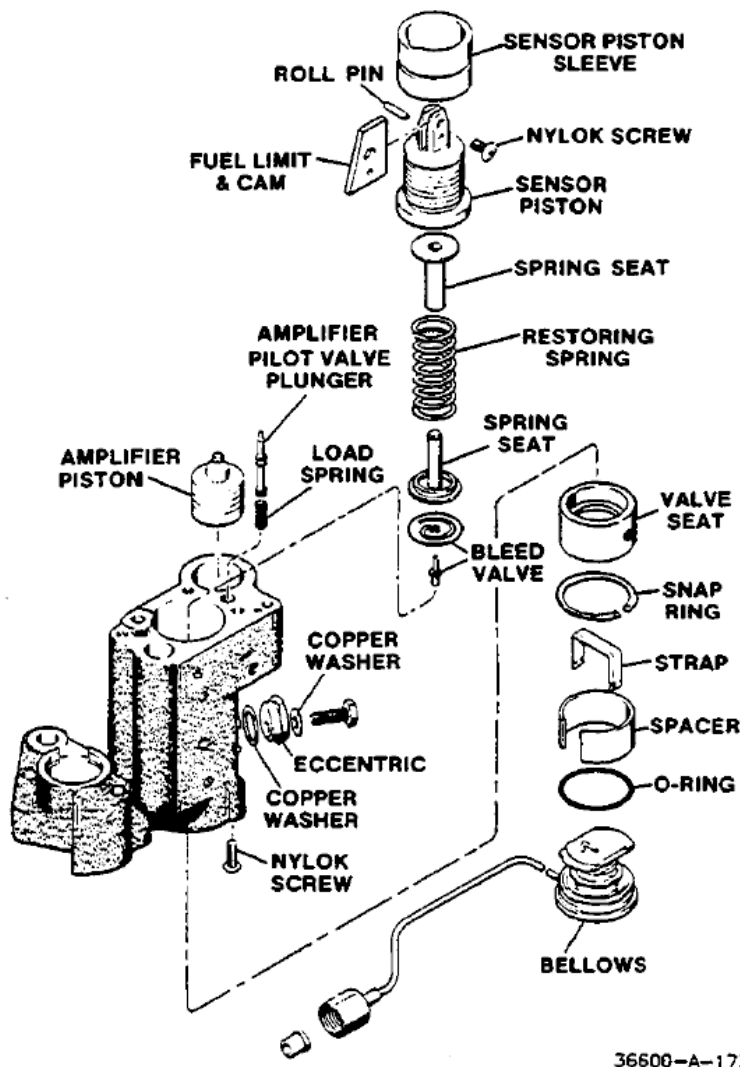

36600-A-173

Figure 5-27. Fuel Limiter Sensor and Bellows

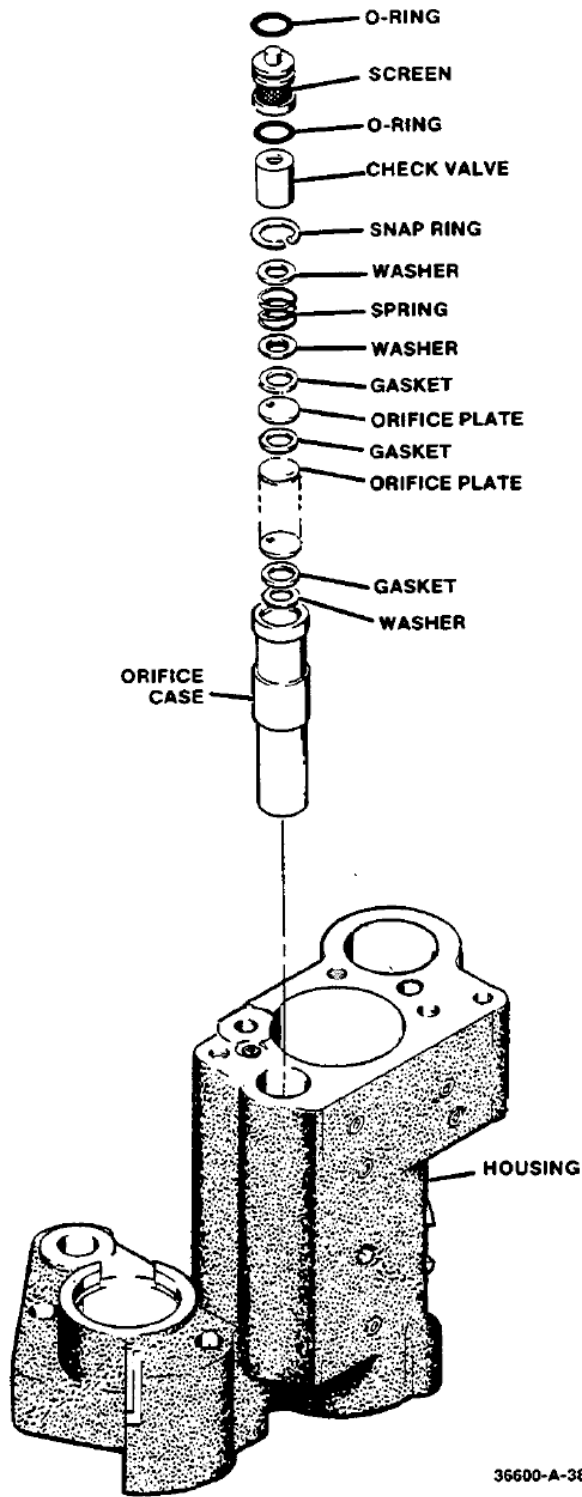

36600-A-389

Figure 5-28. Fuel Limiter Orifice

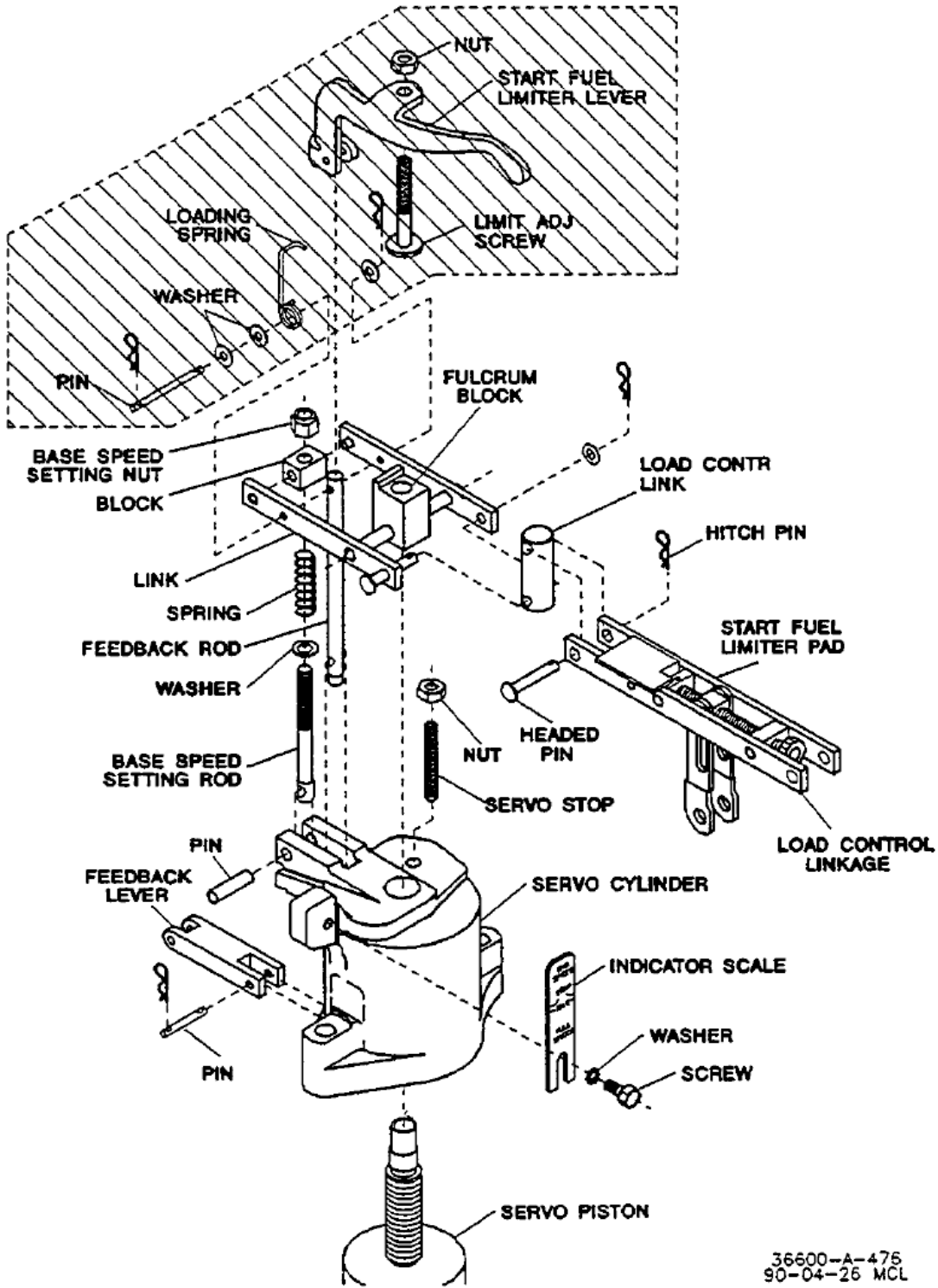

36600-A-476  
90-04-26 MCL

Figure 5-29. Speed Setting Servo  
(Optional start fuel limiter parts are shaded.)

## Repair or Replacement

Repair of parts should be limited to removal of minor nicks, burrs or corrosion. Polish slightly corroded areas in mating surfaces using a fine (600 grit) abrasive cloth or paper and oil. Repair or rework to any greater extent is impractical and the part should be replaced.



### **CAUTION—CARE OF PARTS**

**Handle critical parts with extreme care so that mating edges and surfaces will not be damaged. Sharp edges of plunger lands, piston grooves, metering ports, etc., must be maintained. Rounded edges, nicks, or other damage to such edges will result in excessive internal leakage and/or decreased control sensitivity.**

## Cleaning

1. Clean critical parts by hand.
  - a. Pilot-valve plungers.
  - b. Pilot-valve bushings.
  - c. Compensation piston.
  - d. Servo piston.
  - e. Low-oil shutdown piston.
  - f. Needle valves.
  - g. Bypass valve.
  - h. Load-Control bushing.
  - i. ORS piston.
2. Clean resistor pack by submerging it in clean solvent and shaking it around. Blow dry with a jet of dry air.
3. Pressure wash castings and other parts.

## Lubrication

Lubricate metal parts liberally with lubricating oil at time of assembly. Lubricate O-rings with petrolatum before installation. Also, lubricate any press-fit parts, bearings, and seals before installing.

## Assembly

Assembly should be performed in a dust-free work area.

Replace any damaged or worn parts with new parts.

Replace O-rings, cotter pins, belloframs, and gaskets with new parts. Obtain new O-rings, gaskets, sealing washers, retaining rings, cotter pins, etc., to replace those removed during disassembly. Install retaining rings with sharp edge in the direction of the applied force.

Use "Ersin Multicore Activated Resin Core Solder" or equivalent when making electrical connections to solenoid coil (1106, Figure 7-16) or connectors (1126 or 1134). Use solder sparingly to avoid flow of excess solder through shield washers (1135) which may short circuit the terminals to ground.

## Ballhead

1. Check the toe wear on the flyweights. Flyweight toes support the thrust bearing. Replace flyweights if there is a flat spot larger than 1/32 inch (0.8 mm) wide.
2. Check flyweight pins. Wear on pins indicate bad bearings in the flyweights. Replace both pins and bearings.
3. Check the thrust bearing by placing the bearing between the races and rotating it in your hand. If the bearing feels rough, replace it.
4. Check the main bearing by inserting two fingers inside the inner race and apply pressure while spinning the outer race with your other hand.
5. Check the pilot-valve plunger for nicks and wear. Replace the PVP if it has any nick in the control land larger than 0.001 inch (0.03 mm).
6. Use a light and check inside the PVP bushing. Be sure there are no nicks on the control port.
7. Check the spring coupling by twisting slightly. The spring should not be loose. (See Figure 7-2).
8. Insert PVP and bushing in gear-bushing assembly and secure with snap ring.
9. Install spring coupling in flyweight head. The spring coupling has a missing tooth in its gear and fits in one position only.
10. Put bearing in gear-bushing assembly.
11. Lubricate O-ring and place it on gear bushing.
12. Place small spring and shutdown rod on PVP and secure with PVP nut.
13. Fasten flyweight head to gear-bushing assembly with eight screws.
14. Install flyweights in flyweight head.
15. Place adjusting spring and washer on shutdown rod.
16. Adjust PVP nut until PVP control land is centered in the control port of the PVP bushing. See Figure 5-30 and adjust the PVP nut until dimensions 'A' and 'B' are equal. Make the adjustment (Figure 5-31) while keeping a slight pressure on the flyweights in both directions. Pin nut (with cotter pin) in position once adjustment is correct.

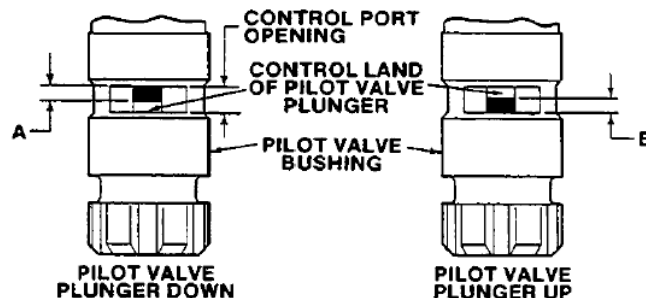

Figure 5-30. PVP Adjustment

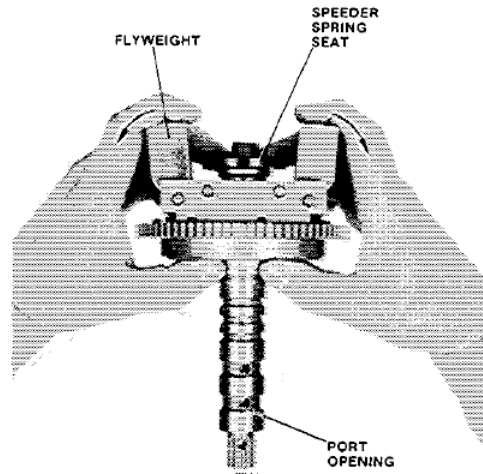

Figure 5-31. PVP Adjustment Procedure

17. Place thrust bearing on shutdown rod with race having largest hole on bottom.
18. Fit speeder spring in spring seat and place it on shutdown rod.
19. Place plug on top of speeder spring. This completes the ballhead assembly.

### Power Servo

1. Check piston and lightly remove any nicks or burrs with a small stone. Check shaft for wear and lightly polish with emery cloth if necessary.
2. Check cylinder for wear and remove nicks with emery cloth as required.
3. Insert piston in cylinder.
4. Press on oil seals just below flush, and press rod end on piston shaft. Secure with taper pin. For screw on type, screw on to 25 lb-ft (34 N·m). Then drill and pin with roll pin.
5. Put nut on tailrod and thread tailrod lift nut onto tailrod and fit the slotted end on piston shaft. Thread tailrod in until there is just enough clearance so tailrod lift nut can turn on piston. Tighten nut on tailrod lift nut to secure it in position.
6. Place gasket on cylinder and spring in cylinder.
7. Use jack screws or some type of guarded press to compress the spring guard on to cylinder and secure it with screws and washers.
8. Install scale.
9. Install spring, seal, and O-ring
10. Check needle-valve seat for wear and install needle valve and washer. Screw in needle valve until it just bottoms. Then and back it off 2 turns.



#### **CAUTION—DO NOT OVERTIGHTEN**

**Do not overtighten the needle valve as this damages the seat.**

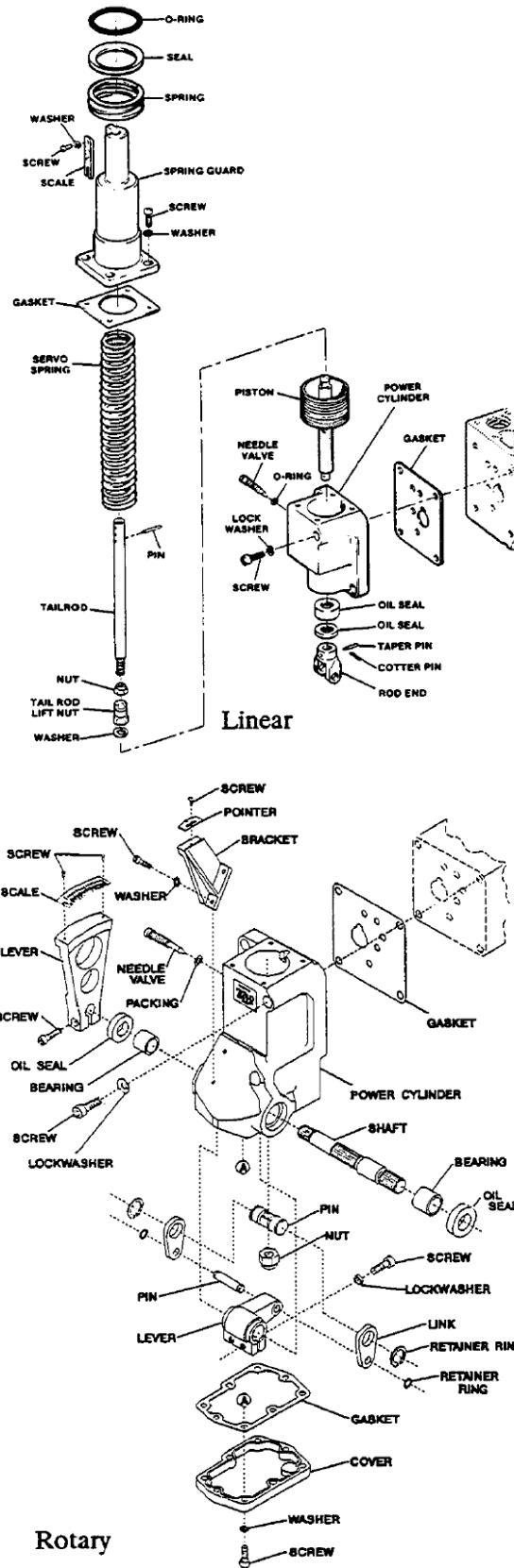

Figure 5-32. Assembly of Power Servos

## Power Case And Base

(Figures 5-33 and 5-34)

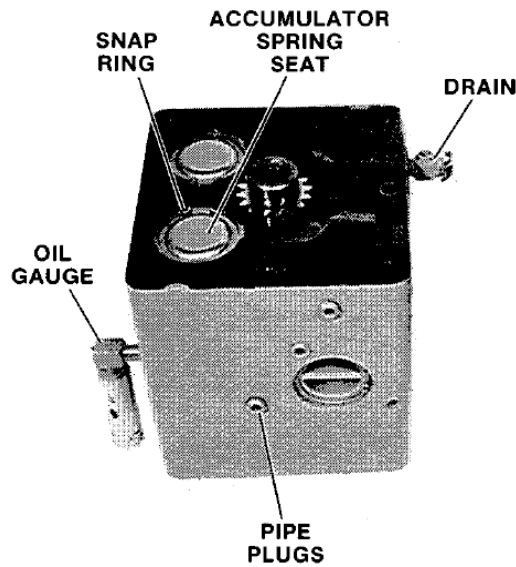

Figure 5-33. Power Case

1. Check for wear in gear pockets. Shiny spots indicate a side load on driveshaft.
2. Check surface (base and column) for burrs, and stone if required.
3. Install both accumulator pistons and secure with snap rings.
4. Use an arbor press and install accumulator springs and seats, and secure with snap rings.
5. Install all pipe plugs, oil drain and oil gauge. Use Loctite on all threads.
6. Install idler gear and check for free movement.
7. Install pump gear and check for free movement.
8. Lubricate and install preformed packing on base end of power case.
9. Place base in position on power case and with 4 screws in center holes on each side of base, secure base to power case. Tighten screws evenly a little at a time. Check alignment by placing driveshaft in position and turn it to check oil pump for free movement. If pump does not move freely, loosen screws in base and reposition slightly until driveshaft turns freely.
10. Insert the other 4 screws in base and tighten. Torque to 90 lb-in (10.1 N·m) nominal.
11. Check driveshaft for wear in area where seal fits.
12. Replace bearing on driveshaft with a new bearing unless none is available and the old bearing is not damaged too badly. See Figure 5-34.

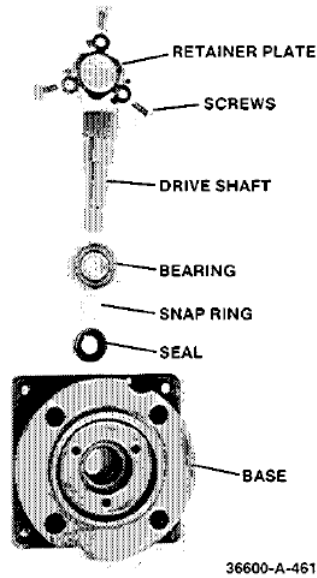

Figure 5-34. Drive Shaft and Base

13. Install gasket on seal and place into base.
14. Install driveshaft and secure with retainer plate and screws. Torque screws to 63 lb-in (7.1 N·m) nominal.
15. Bend ears of retainer plate to secure screws.
16. Put new O-ring on seal (Figure 5-35) and insert spring and plug into compensation cylinder in power case. Secure plug with snap ring.

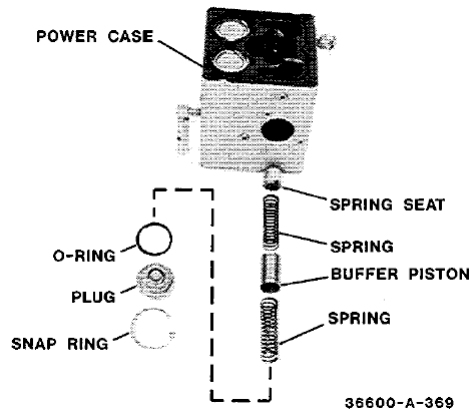

Figure 5-35. Compensation System

17. Lay power case on its side and insert piston spring and spring seat in compensation cylinder on servo side of power case. Be sure both springs fit into ends of buffer piston.
18. Install gasket and power servo.

**NOTE**

When governor is on test stand and is at operating temperature, torque screws to 40 lb-ft (54 N·m).

19. Reassemble water box and attach it to power case.
20. Put small gasket in top of power case (Figure 5-36.

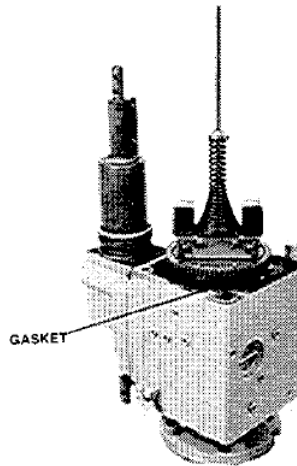

Figure 5-36. Power Case Assembly Complete

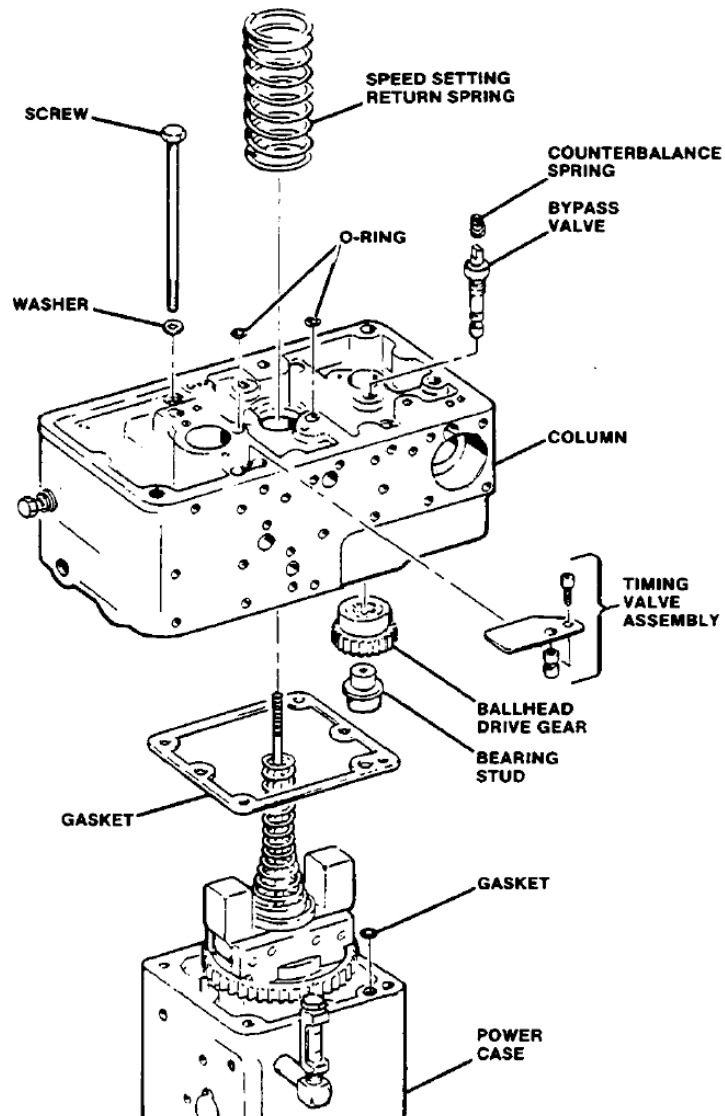

Figure 5-37. Column to Power Case Assembly

21. Insert ballhead assembly in position in power case.

**Column**

(Figures 5-38 through 5-66)

1. Check ballhead drive-gear teeth. If gear is okay, place in position in bottom of column.
2. Clean both timing valves, replace O-rings on needle valves, insert in column, and secure with retainer plate, instruction plate, lockwasher and screw (Figure 5-38).

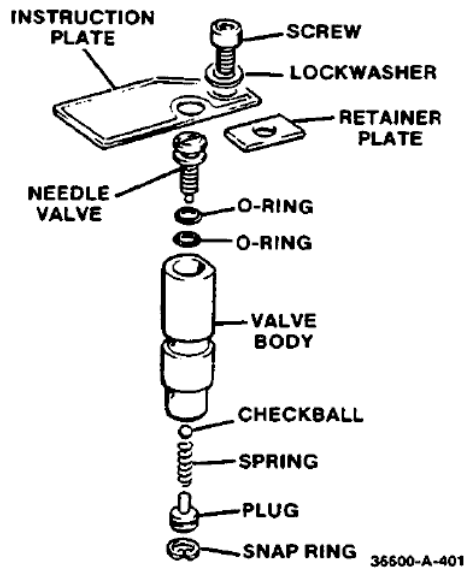

Figure 5-38. Timing Valve

3. Install bulkhead union assembly as shown in Figure 5-39.

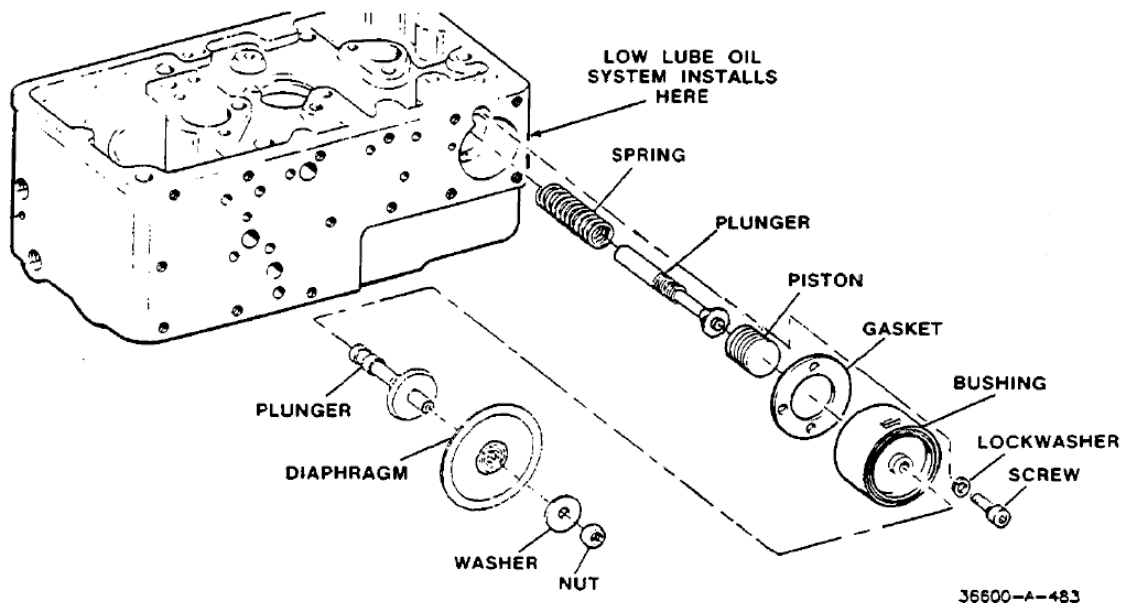

Figure 5-39. Lube Oil Shutdown

4. Insert gasket, plunger, spring, piston, and bushing into hole for low-oil shutdown (Figure 5-39).
5. Assemble diaphragms as shown in Figure 5-39 or 5-39A.



**NOTE**

Do not let the diaphragm twist or buckle while tightening the nut.

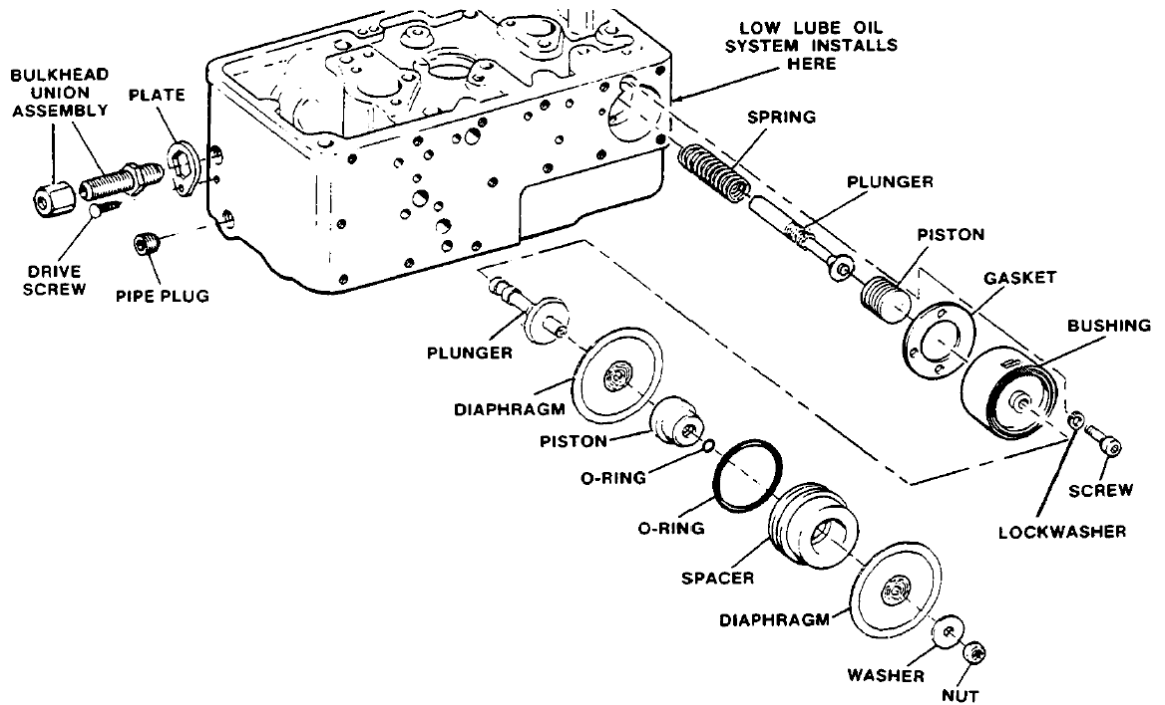

Figure 5-39A. Differential Area Lube Oil Shutdown

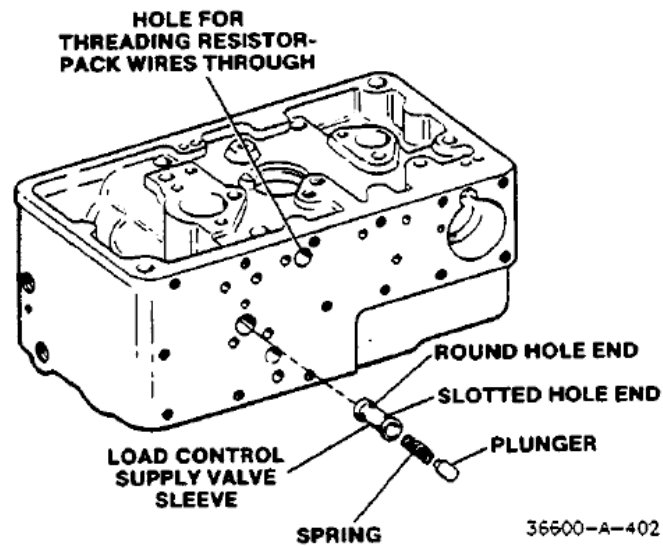

Figure 5-40. Load Control Supply Valve

6. Tighten nut on plunger to secure assembly.

7. For differential-area lube-oil shutdown, roll diaphragm into area around piston inside of spacer. Do not use a sharp tool to start the diaphragm; usually it can be started with your finger.
8. Insert diaphragm assembly into cylinder for lube-oil system.
9. Install load-control supply valve in order as shown and in correct hole in column.
10. Replace bearings, if required, in end plate. See Figure 5-41. Use a brass punch through bearing end to remove end cap. Then reverse end plate and drive out bearing. Press fit new bearings into both end plates.

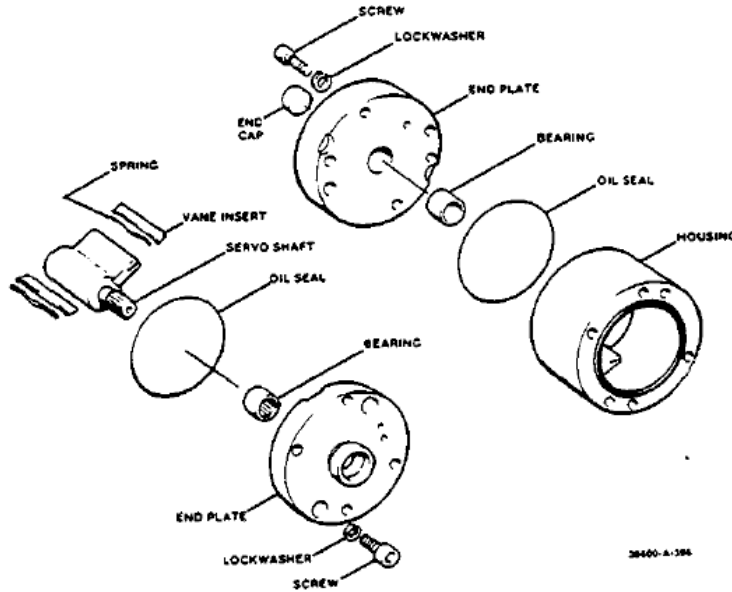

Figure 5-41. Vane Assembly

11. Assemble servo shaft, vane inserts, and springs into housing.



**NOTE**

Use new springs with vane inserts.

12. Put oil seals in place on housing and secure end caps to housing with screws and lockwashers.
13. Install three O-rings, shown in side plate, Figure 5-42.

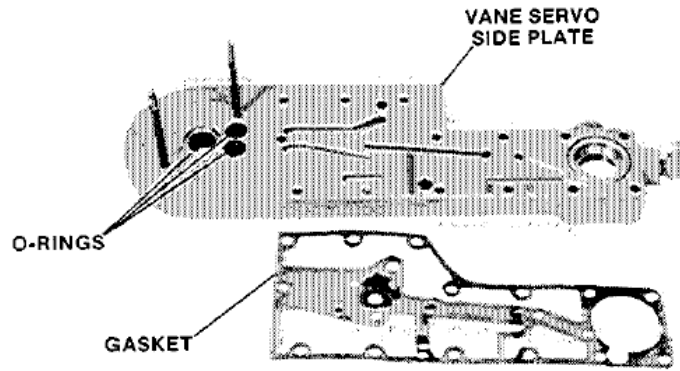

Figure 5-42. Side Plate

14. Secure commutator plate, and wire retainer to resistor pack with screws and nuts (Figure 5-43).

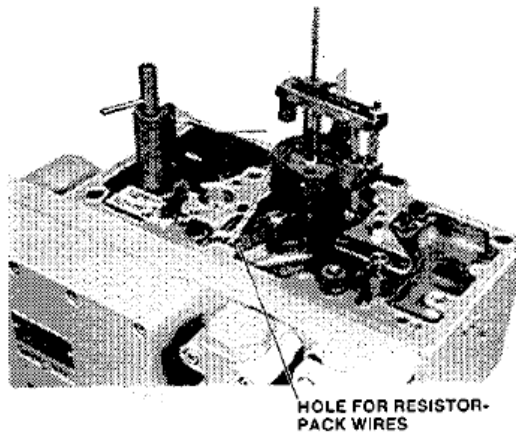

Figure 5-43. Wires Threaded into Column

15. Place gasket in position on side of column.
16. Attach side plate to column with 10 screws. Torque screws to 75 lb-in (8.5 N·m). To insure plate flatness, when torquing screws, start from the center and work your way to the ends.
17. Thread resistor-pack wires through gasket, side plate, gasket, and hole in column (Figures 5-44, 5-45).

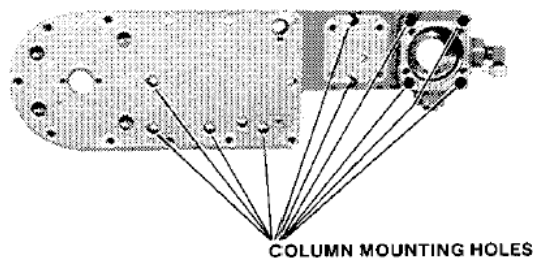

Figure 5-44. Side Plate Mounting Holes

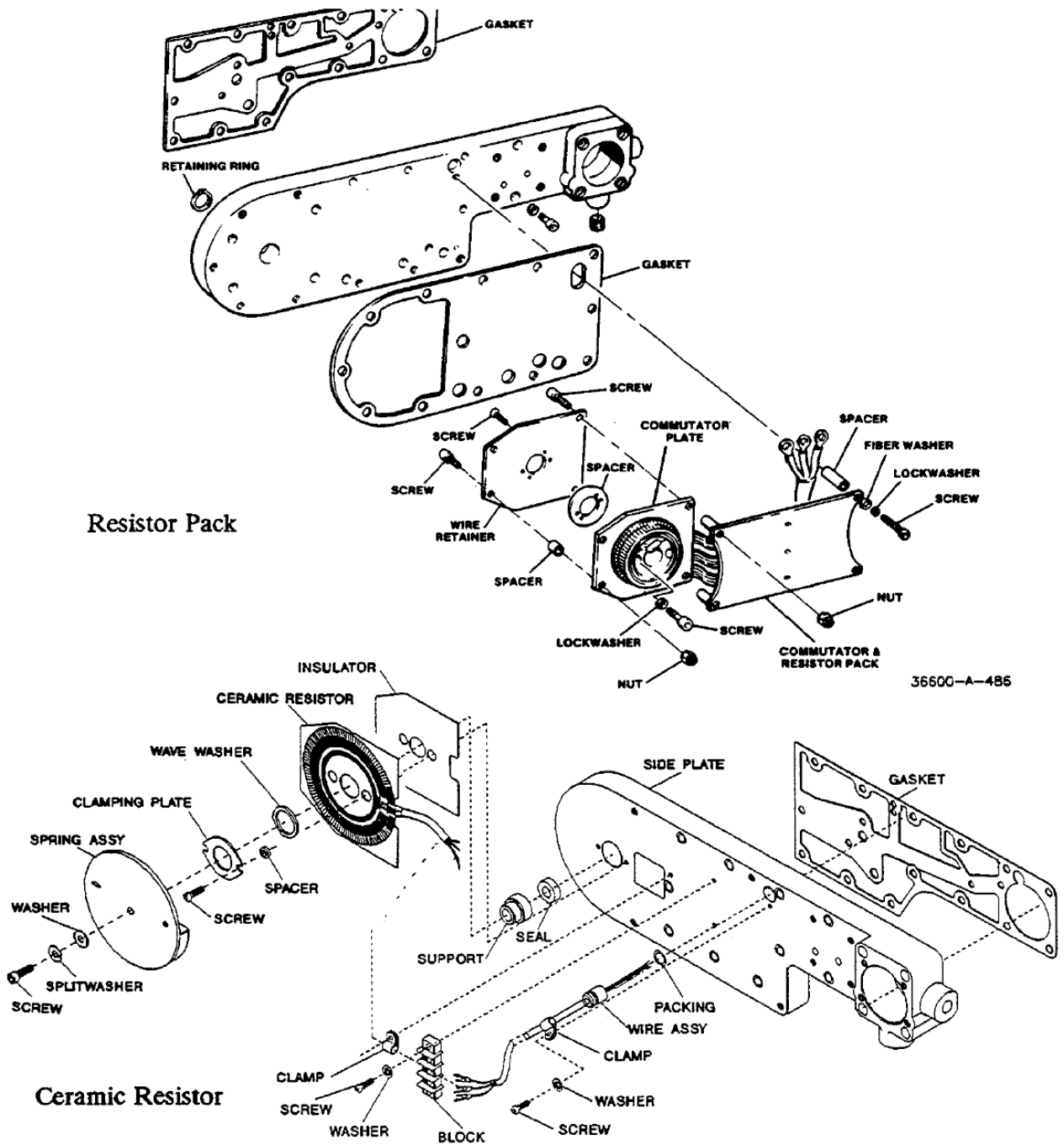

Figure 5-45. Resistor Pack and Side Plate Assembly

18. Attach resistor pack to side plate. First, use 2 screws through commutator, but do not tighten. Second, in order as shown on Figure 5-45, secure right-hand side of resistor pack to column. Tighten screws on left-hand side in commutator.
19. Insert end of shaft in contact plate assembly (Figure 5-46), through commutator and side plate, and secure with retaining ring. Lift up gently on contact so it slides over commutator.

**CAUTION—DO NOT BEND CONTACT**

Do not bend contact on plate as you slide the plate in position.

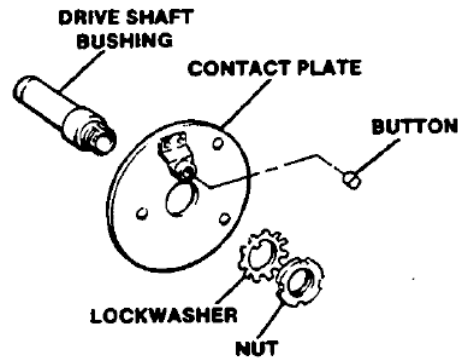

Figure 5-46. Contact Plate Assembly

20. Make sure the vane has maximum amount of travel. If necessary, pull contact plate out slightly and rotate positioning of teeth to obtain maximum travel.
21. Secure contact-plate shaft with snap ring.
22. Attach vane assembly to side plate with lockwashers and nuts.
23. Attach side-plate cover to side plate. Holes in top right (Figure 5-47) need four 3 inch (76 mm) long screws. Eight other holes require 2-1/8 inch (54 mm) screws.

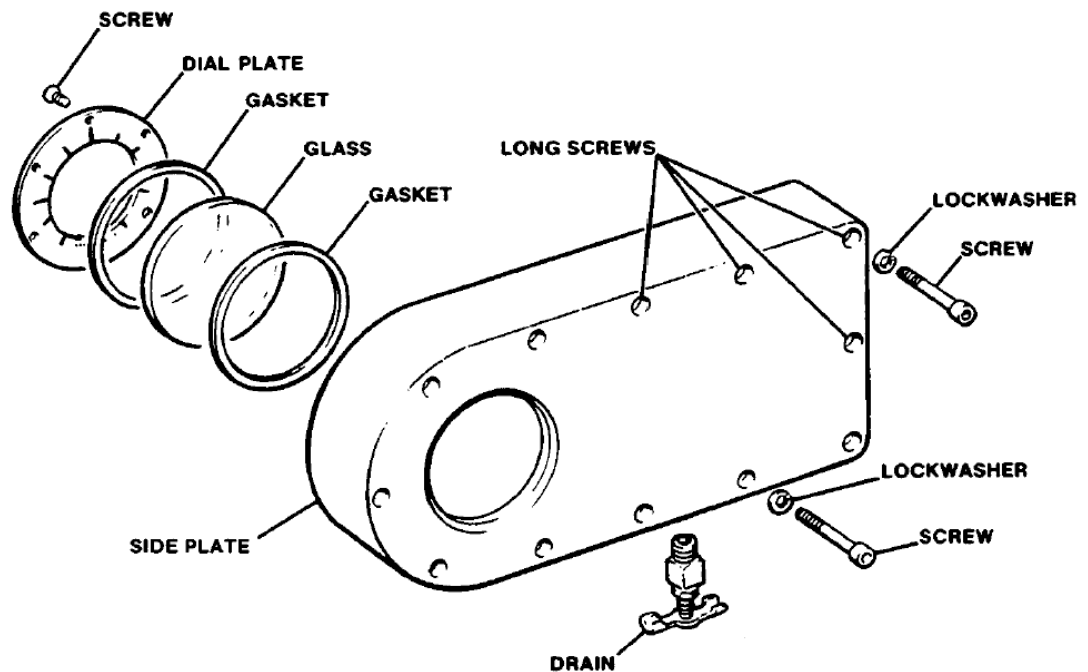

Figure 5-47. Side Plate Cover

24. Assemble oil filter after cleaning it and mount it in position on vane servo side plate (Figure 5-48).

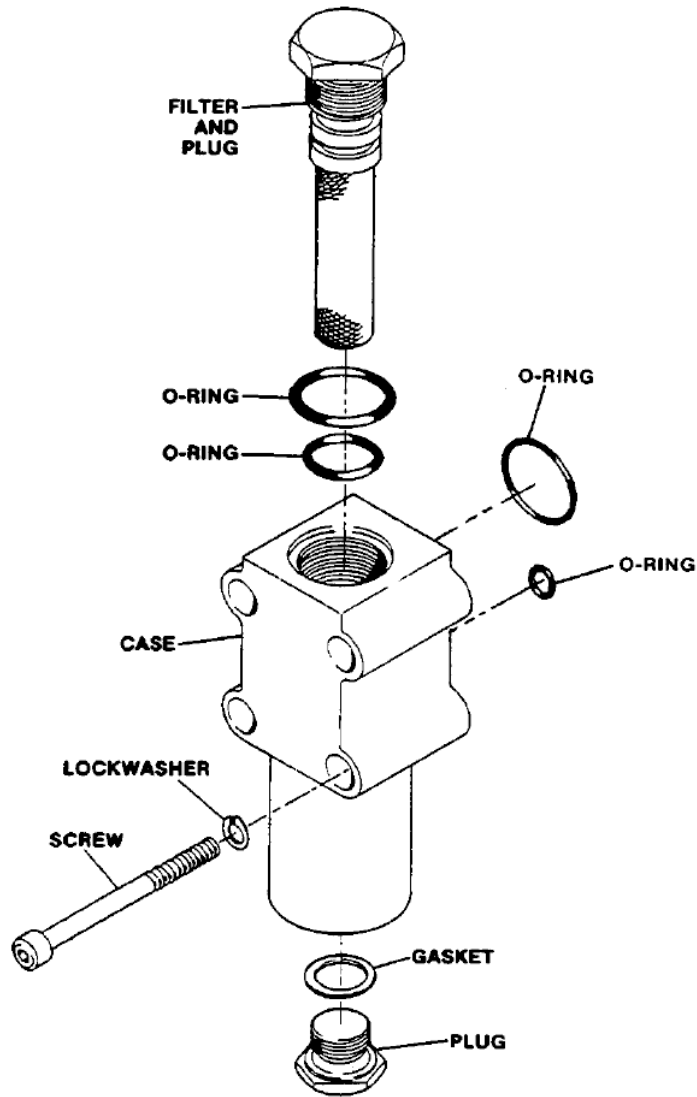

Figure 5-48. Oil Filter

25. Install load spring, spring seat, O-ring, and end cap. Secure with lockwashers and screws (Figure 5-49).



**NOTE**

During test on test stand, adjust shutdown point and then install plug in end cap. Use Loctite 242 on outside diameter of plug.

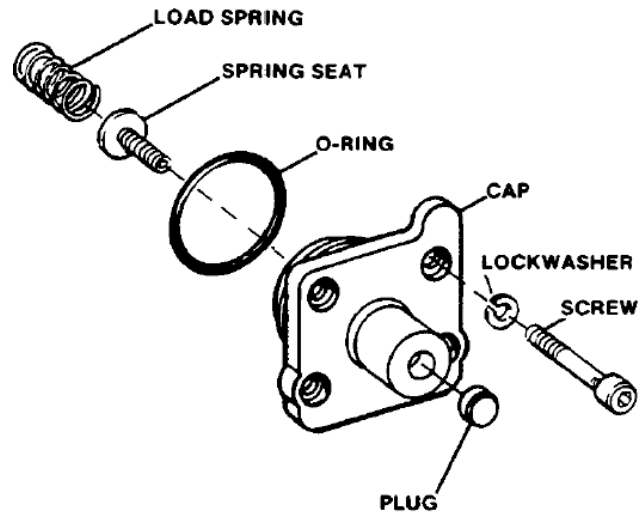

Figure 5-49. Lube Oil Shutdown Cap

26. Clean, assemble, and install bypass valve in position as shown in Figure 5-50.

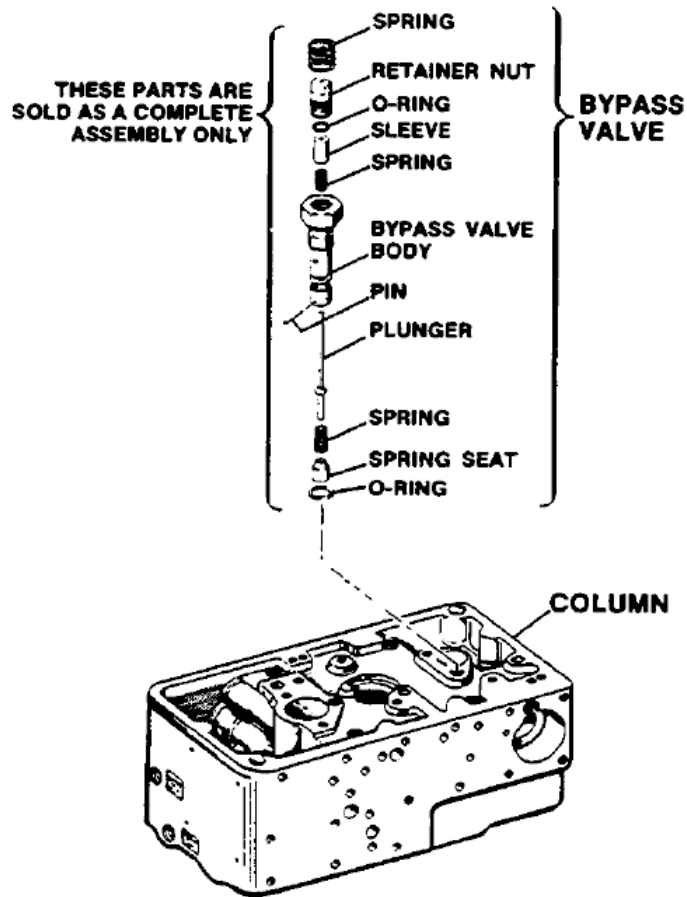

Figure 5-50. Bypass Valve

27. Assemble load-control linkage as follows:
- a. Install snap ring in load control bushing (Figure 5-51).

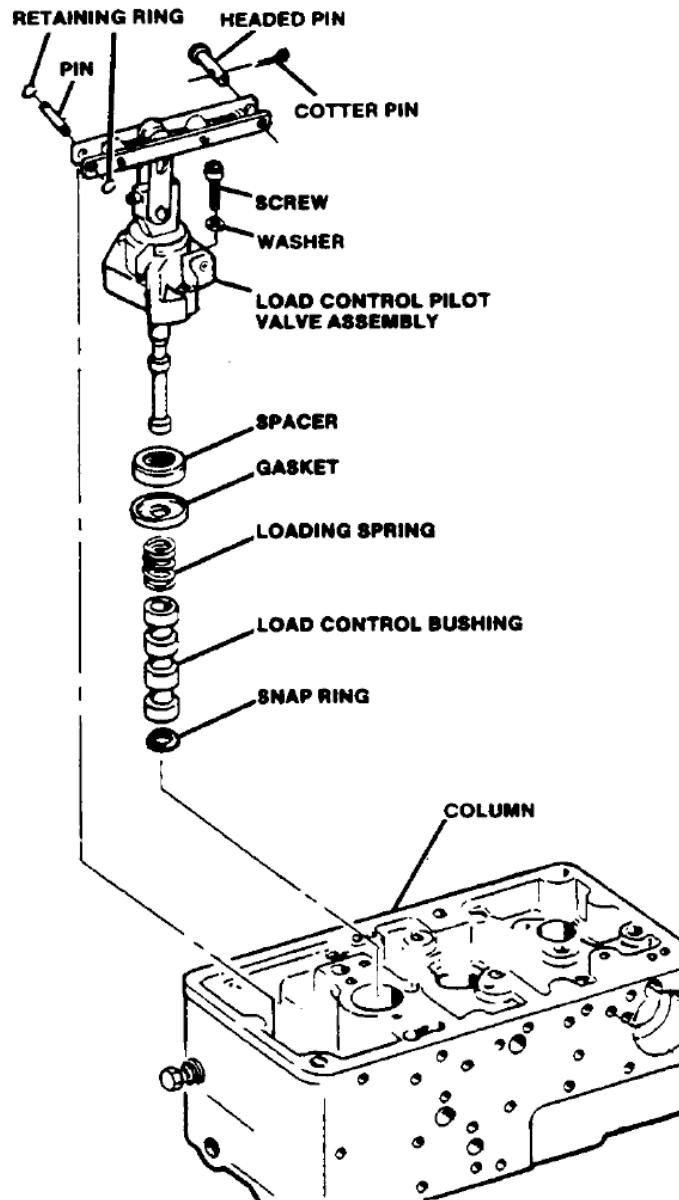

Figure 5-51. Load Control Bushing

- b. Put load control bushing into column bore; install load-control pilot-valve plunger, spring, gasket, and spacer.
- c. Press the cylinder head into cylinder, (Figure 5-52).
- d. Place O-ring in counterbore in column; slip cylinder over pilot-valve stem and tighten down with screws and washers.
- e. Install overriding piston.
- f. Hold pilot-valve plunger down against snap ring and use Woodward tool 360692 or equivalent (Figure 5-53.) to thread spring seat onto plunger stem. Turn spring seat down until it touches overriding piston; then back off 1/4 turn. (Plunger will begin to rise if spring is turned down further on thread after touching piston.)

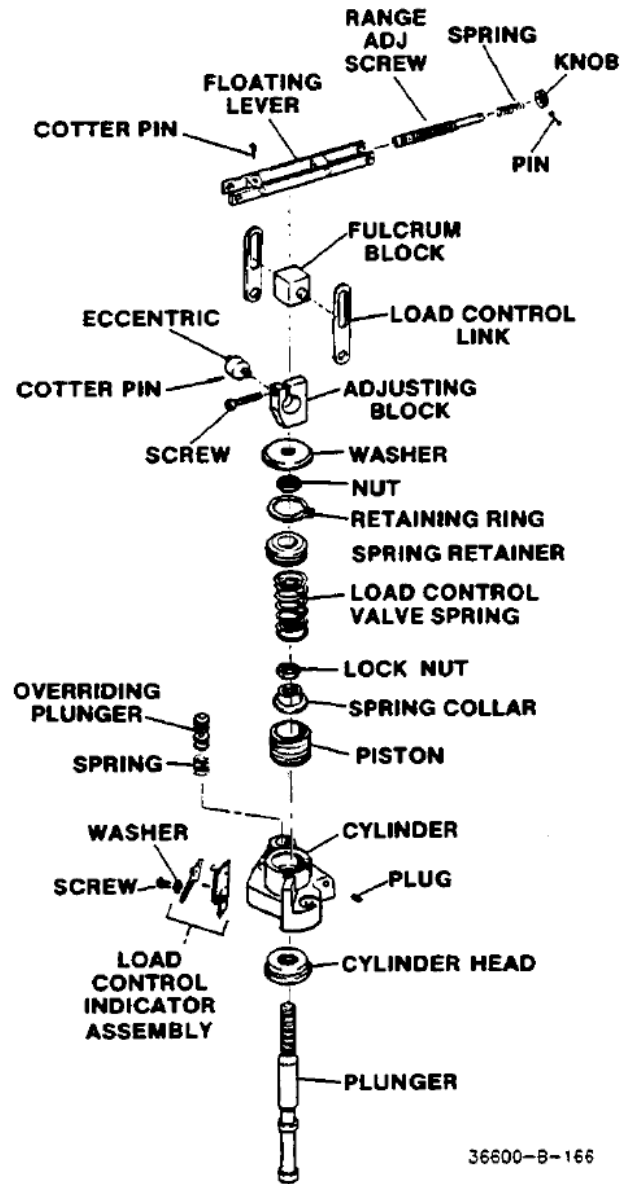

Figure 5-52. Load Control Pilot Valve Assembly

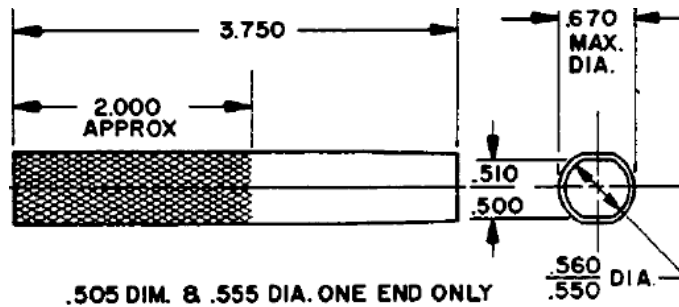

Figure 5-53. Spring Seat Tool

- g. Lift pilot-valve plunger sufficiently far to permit holding spring collar with a wrench while locking in position with locknut.



### CAUTION—PROTECT OIL SEAL

Do not lift plunger higher than necessary, to avoid damaging oil seal.

- h. Install spring, spring retainer, and retaining ring.  
 i. Thread locknut onto pilot-valve plunger stem and install washer.  
 j. Assemble block, eccentric, load-control link, fulcrum block, floating lever, range-adjustment screw, spring, and knob.  
 k. Thread adjusting block of the floating-lever assembly about 10 turns onto the pilot-valve plunger, lock in place with locknut.
28. Check thrust bearing for wear and replace if necessary.
29. Check pilot-valve plunger and rotating bushing for damage or wear and repair or, replace it necessary. Be sure there are no nicks or burrs on any lands. Lightly stone any nicks or burrs with a hard Arkansas stone.
30. Insert loading spring, rotating bushing, regulating bushing, small pilot-valve loading spring, pilot-valve plunger, and thrust bearing (Figure 5-54). Install thrust bearing with large race on top.

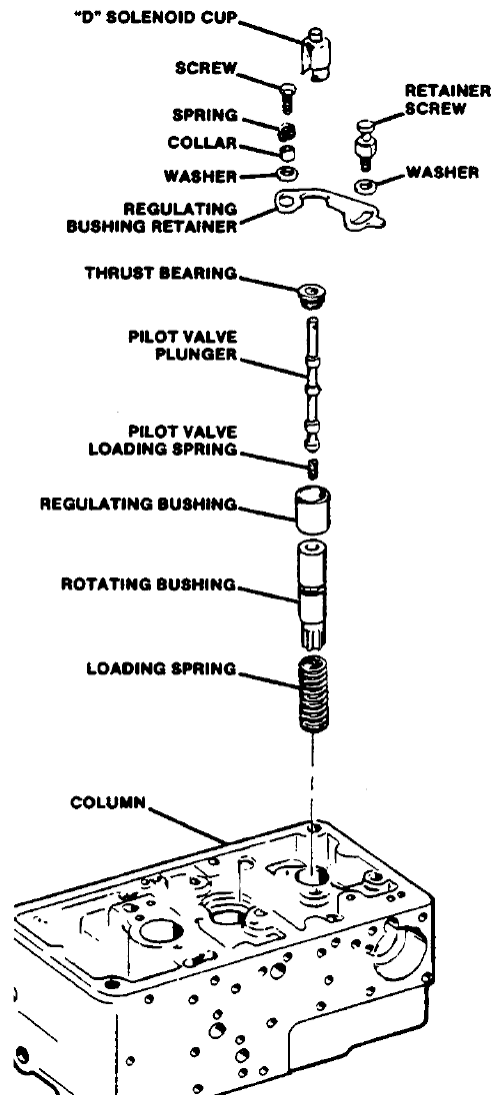
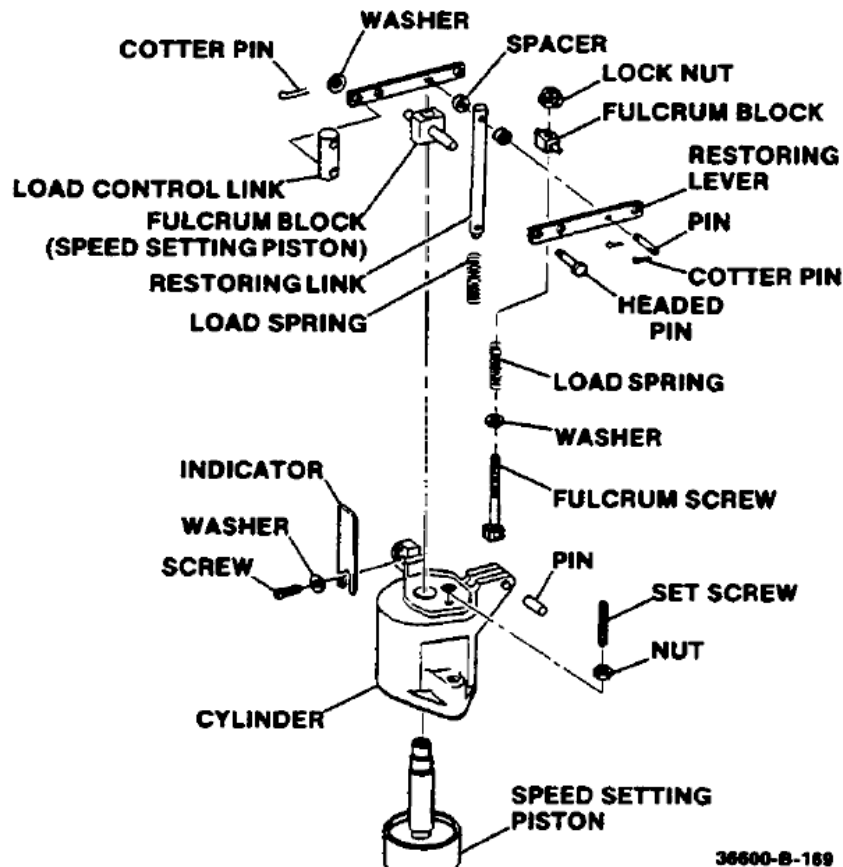

Figure 5-54. Speed Setting Valve

31. Attach indicator with screw and washer.
32. Assemble speed-setting servo (Figure 5-55).
  - a. Insert piston through cylinder and fulcrum block.
  - b. Place both fulcrums in position between restoring-lever straps.
  - c. Place restoring link and spacers between restoring levers and secure assembly together with pin and cotter pins.
  - d. Install fulcrum screw, washer, spring, and secure with nut.
  - e. Attach square end of fulcrum screw with pin.
  - f. Install setscrew and nut.
  - g. Attach load-control link with headed pin and secure with cotter pin.

**CAUTION—CARE OF PARTS**

When doing the following step, be careful not to buckle triangular plate. Also, be careful not to warp flat springs on triangular plate while you tighten screws.



36600-B-169

Figure 5-55. Speed Setting Servo

33. Set speed-setting cylinder assembly in place and fit triangular plate under top of retaining screw. Secure both to column with screws and washers. Torque screws to 50 lb-in (5.6 N·m) (Figure 5-56).
34. Fit "D" solenoid cup (opening toward speed-setting servo) and regulating-bushing retainer in position on top of thrust bearing and secure with washer, collar, spring and hex head screw.

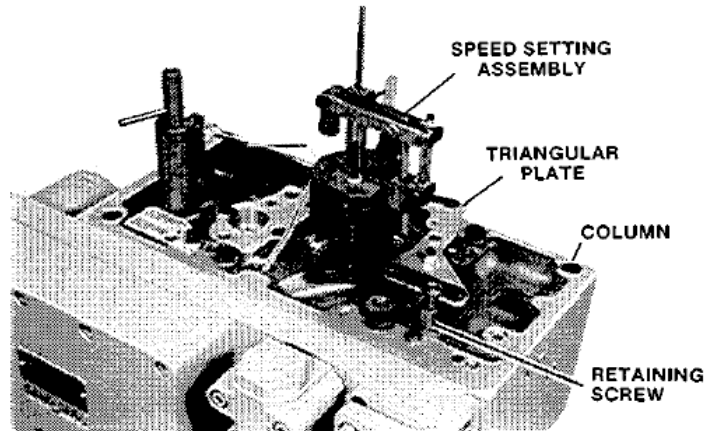

Figure 5-56. Speed Setting and Triangular Plate

35. Install washer and retainer screw, set pointer to punch mark in column surface, and tighten retainer screw.
36. Limiter assembly (Figures 5-57, 5-58, 5-59).
  - a. Clean orifice screen.
  - b. Replace old check valve, O-rings, and gaskets with new ones.
  - c. Orifice plates must have holes 180 degrees out of phase when assembled in case.
  - d. After assembly in case, install in limiter housing.
  - e. Lubricate and put new O-ring on bellows.
  - f. Check bleed valve in valve-seat contact areas for nicks or burrs. If either of these critical areas are damaged, replace it with a new part.
  - g. Put valve seat in housing (with seat up) and install snap ring.
  - h. Install spacer and bellows, and secure with new Nylok screws.
  - i. Use new copper washers and install eccentric in housing.
  - j. Insert bleed valve, spring seat, restoring-spring seat, sensor piston, and sleeve (Figure 5-58).
  - k. Insert loading spring, pilot-valve plunger, and amplifier piston.
  - l. Assemble bearing in bellcrank and secure bellcrank to linkage bracket with pin and cotter pin.
  - m. Turn in adjusting screw. Place feedback lever in position and secure floating lever to bellcrank with cotter pin.
  - n. Place fuel-limit lever in place on the bracket and secure with pin and cotter pin.
  - o. Attach fuel-limit lever to bracket and secure with cotter pin.
  - p. Attach linkage assembly to housing with 3 screws.
  - q. If it is present, assemble overriding solenoid (ORS) bracket and attach it to overriding solenoid (Figure 5-61).



**NOTE**

See Figure 5-59 which shows linkage arrangement of fuel limiter.

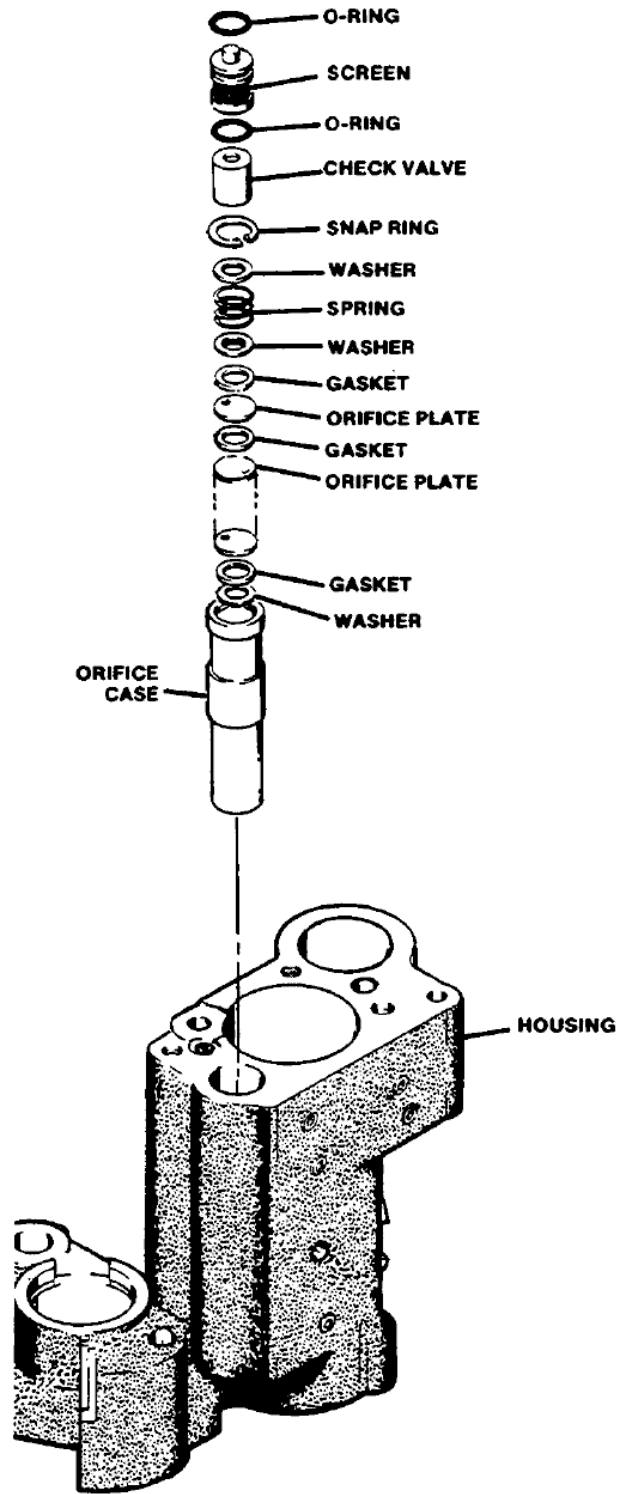

Figure 5-57. Fuel Limiter Orifice

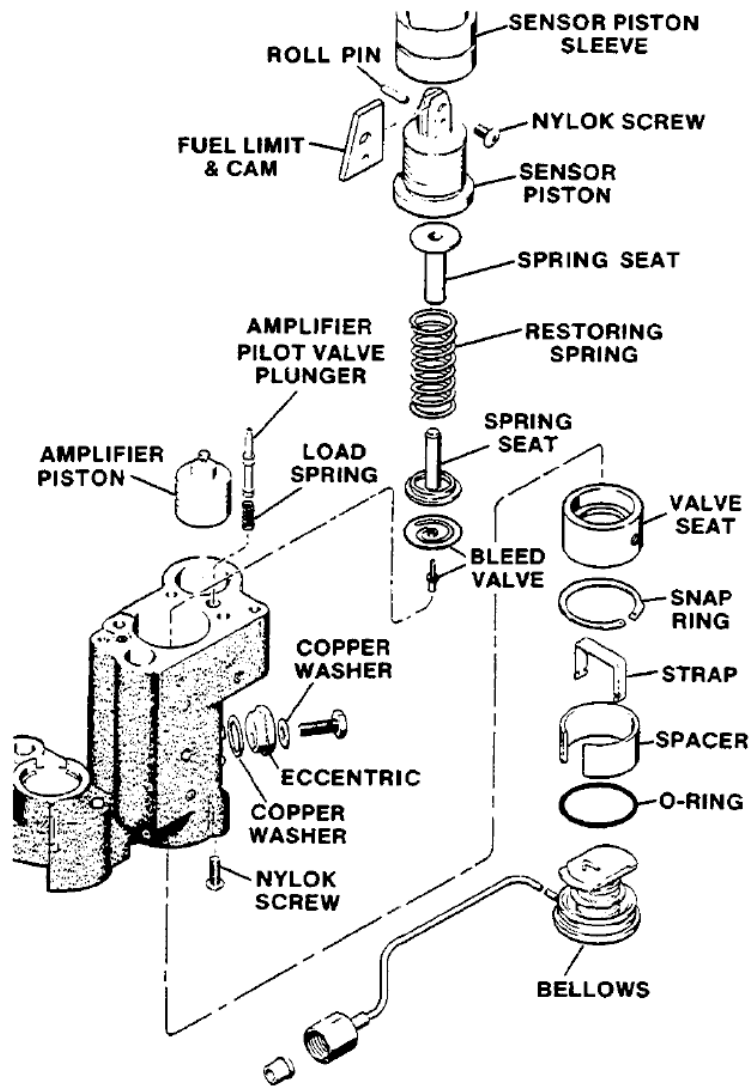
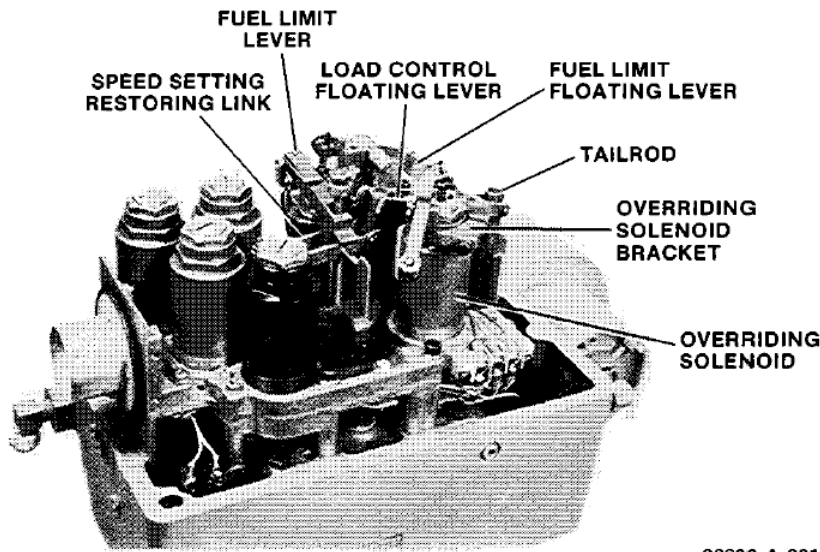

Figure 5-58. Fuel Limiter Sensor and Bellows



36600-A-381

Figure 5-59. Linkage Arrangement

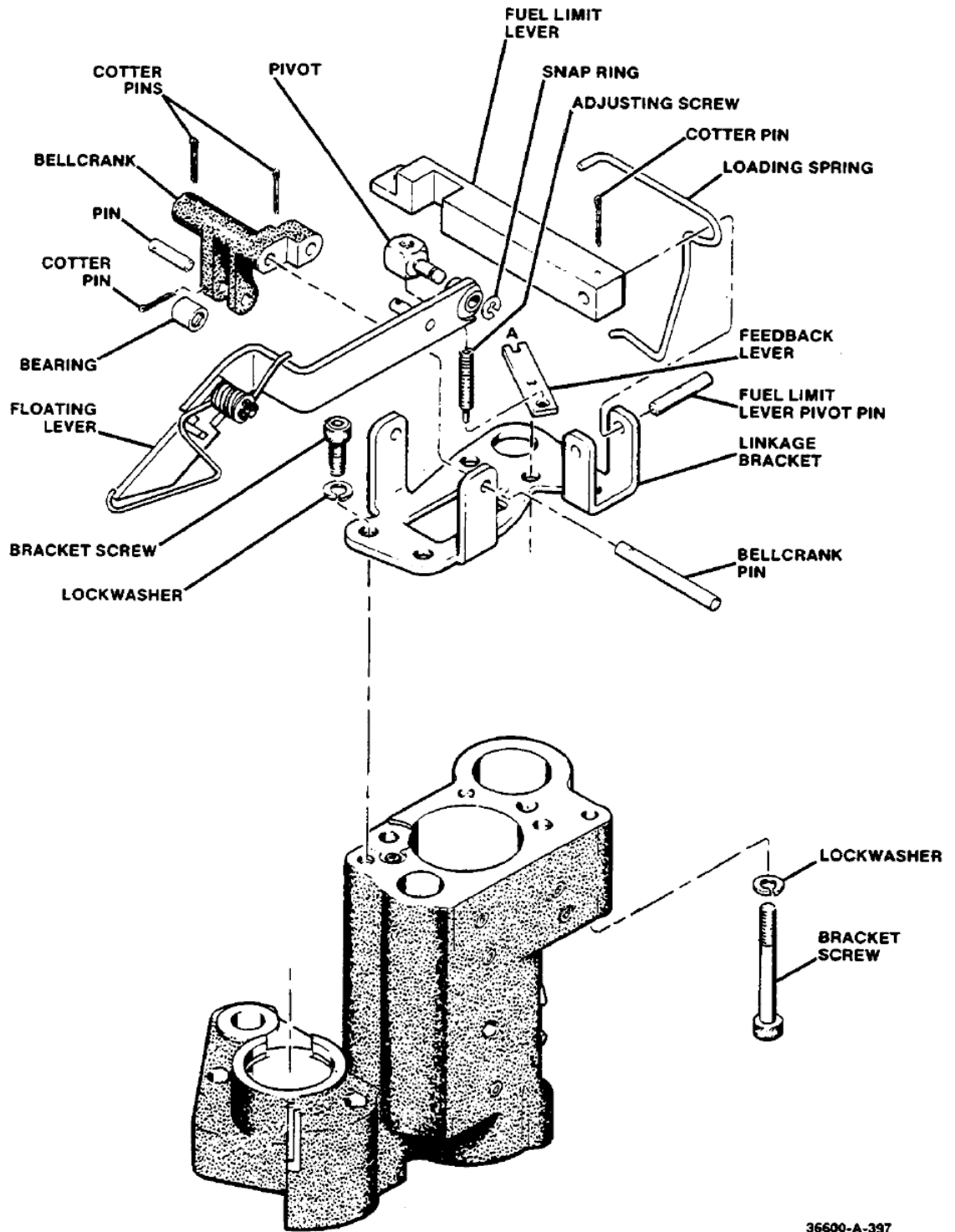

Figure 5-60. Fuel Limit Bracket and Linkage

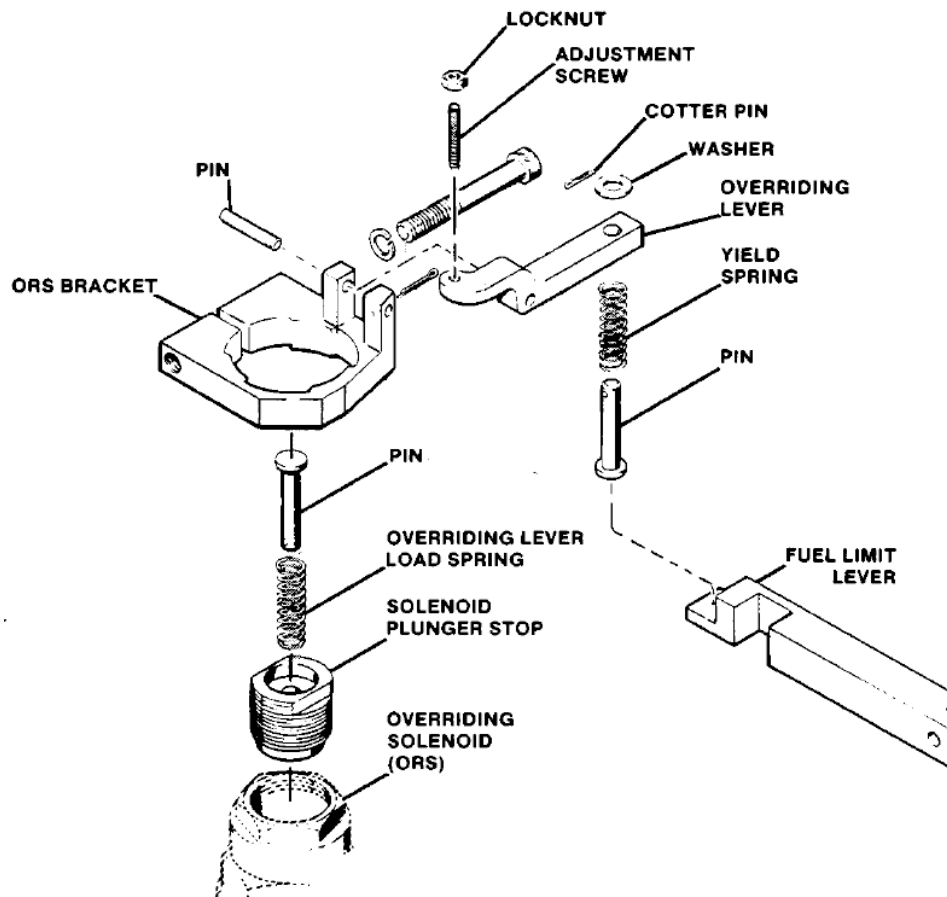

Figure 5-61. ORS Bracket

37. Install fuel limiter/load control assembly (Figure 5-62) in column.

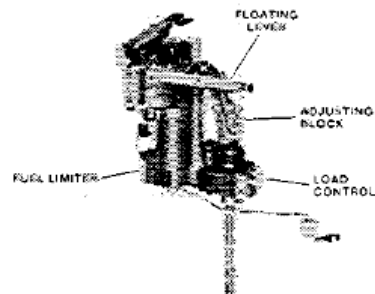

Figure 5-62. Fuel Limiter and Load Control Assembly

38. Attach linkage of fuel limiter, load control, and speed setting as shown in Figure 5-63.

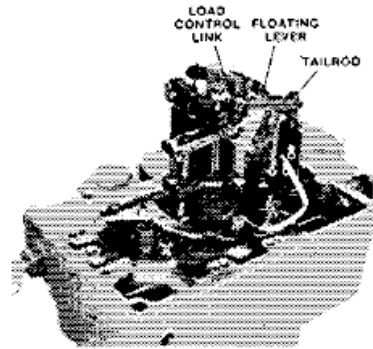

Figure 5-63. Floating Lever Connection

39. If pressure-biased load control is present, assemble as shown in Figure 5-64.

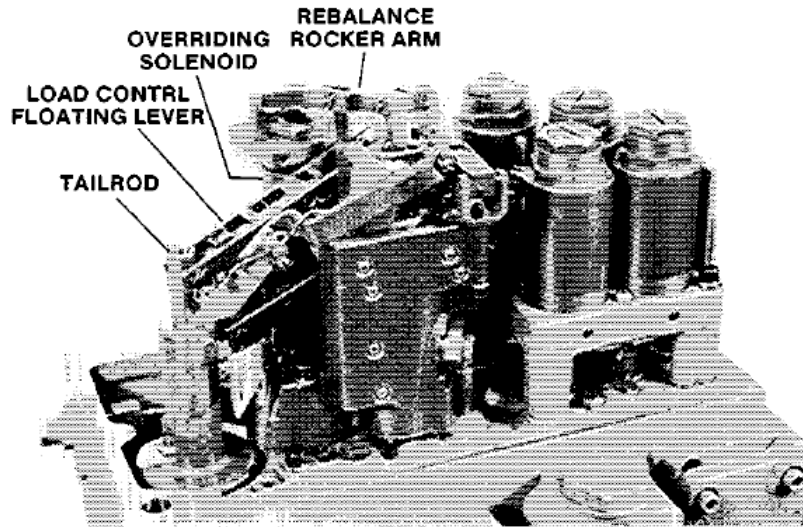

Figure 5-64. Lever and Linkage with Overriding Solenoid

40. See Figure 5-66. When assembling the water box, install both diaphragms so that fabric sides face each other. Install diaphragm washers so that the side with the radius is against the diaphragm.

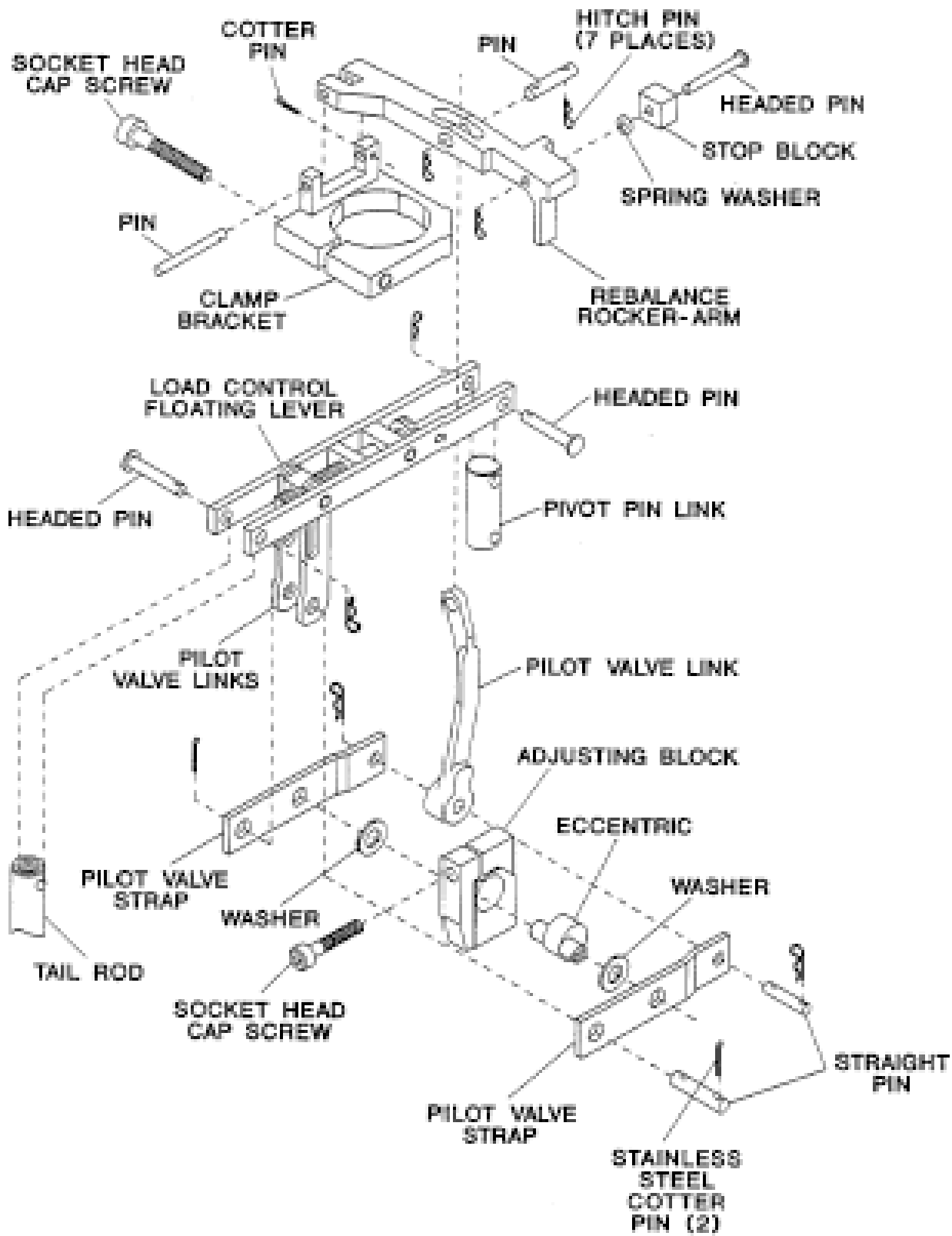
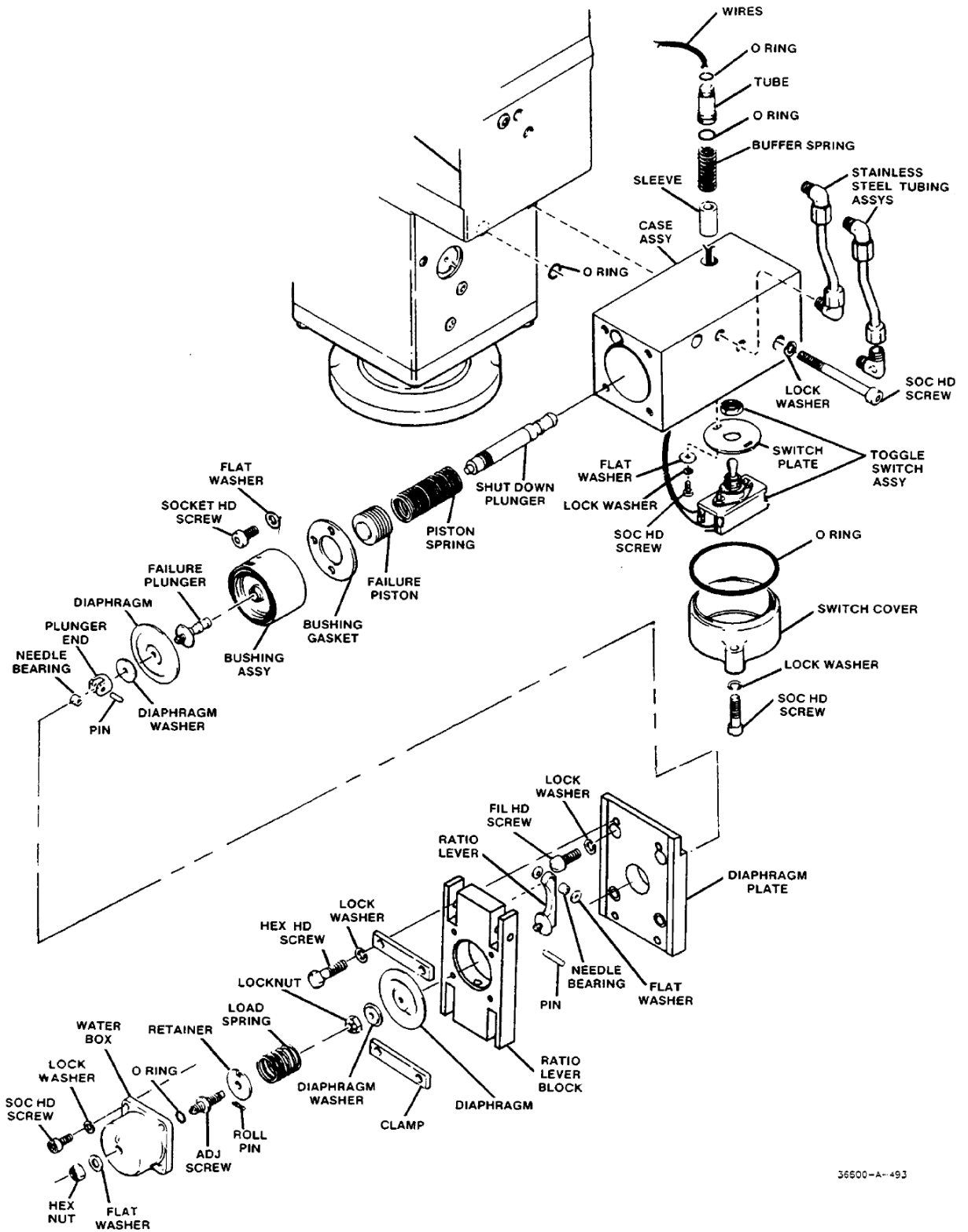

Figure 5-65. Lever and Linkage



36500-A-493

Figure 5-66. Water Box

# Chapter 6.

## Test and Adjustment

### Test Setup

1. Make the following settings on the test stand before starting the test.
  - a. Turn heater switch to "O2N."
  - b. Turn oil pump switch to "OFF."
  - c. Set air gauges to zero.
  - d. Close valves.
  - e. Set direction of rotation for the governor under test.
  
2. Mount governor on test stand. See Figures 6-1, 6-2, and 6-3, and make the following connections:
  - a. Electrical (remove cover first)
  - b. Governor oil pressure gauge
  - c. Drain
  - d. Float
  - e. Fill
  - f. Fuel-limiter pressure (if fuel limiter is present)
  - g. Low lube oil pressure (air or oil)
  - h. Low water pressure (air or oil)
  - i. Servo rod end to test stand
  
3. Test Specifications (TSPs) for each PGE and PGEV part number are available from Woodward Governor Company or your nearest authorized service facility. These TSPs reflect calibration instructions and set points. Calibration should not be attempted without the appropriate TSP. Use the information in the appropriate TSP (for your governor part number) to calibrate your governor.
  
4. To locate adjustable components, refer to Figures 6-1 through 6-6 below.

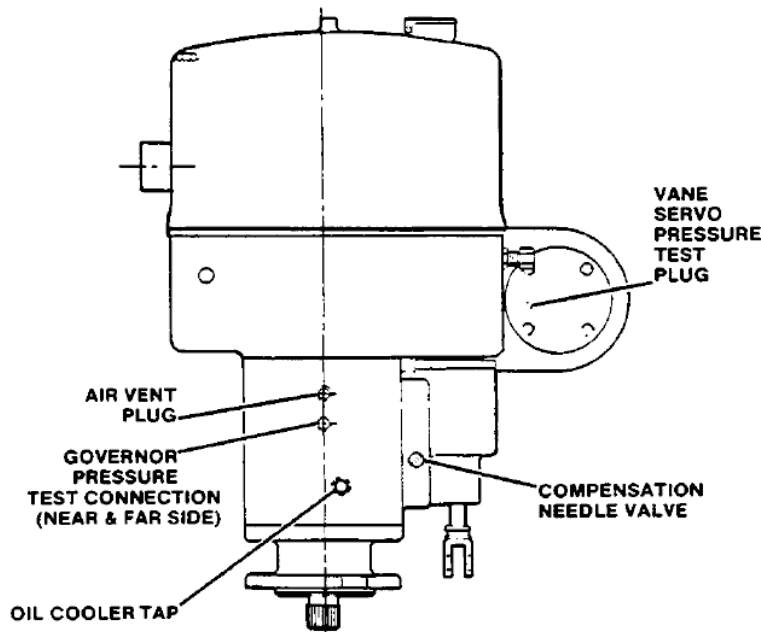

Figure 6-1. PGEV Test (Right-hand Side)

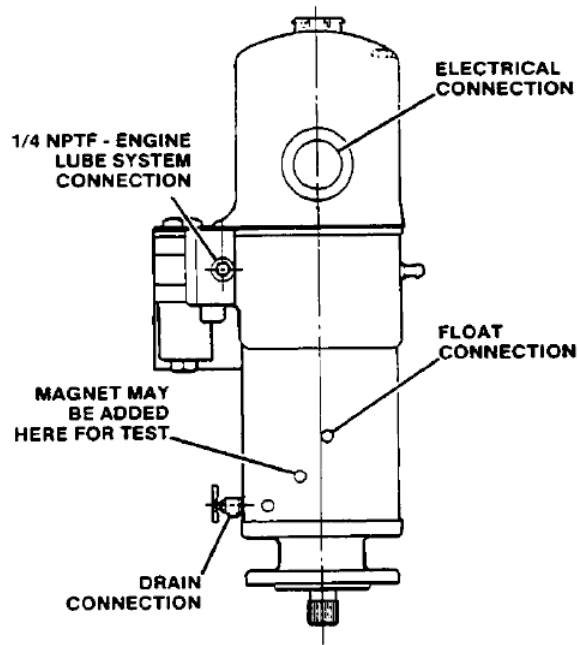

Figure 6-2. PGEV Test (Front)

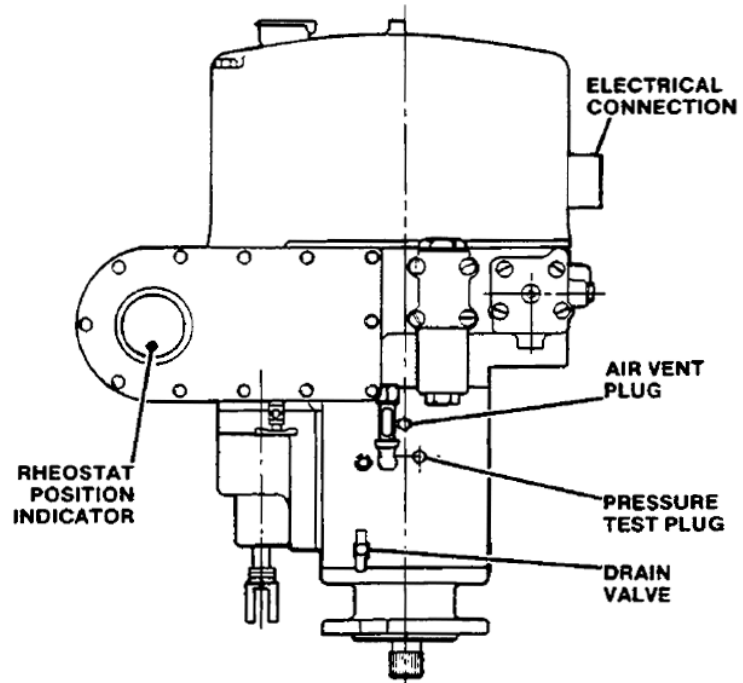

Figure 6-3. PGEV Test (Left-hand Side)

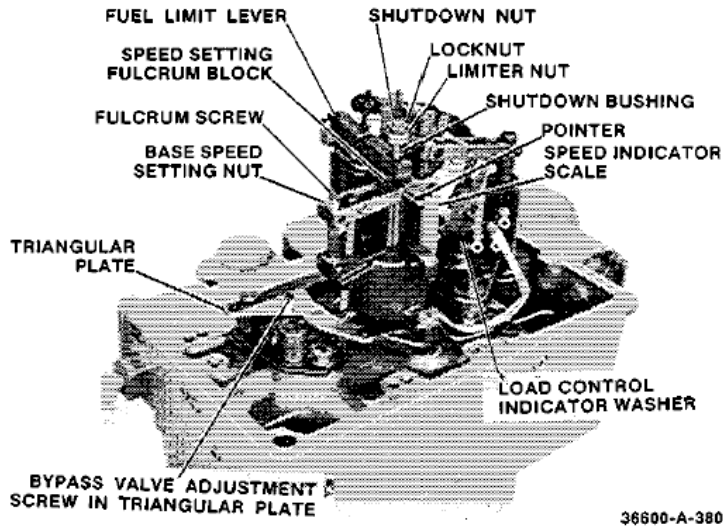

Figure 6-4. Speed Setting Assembly

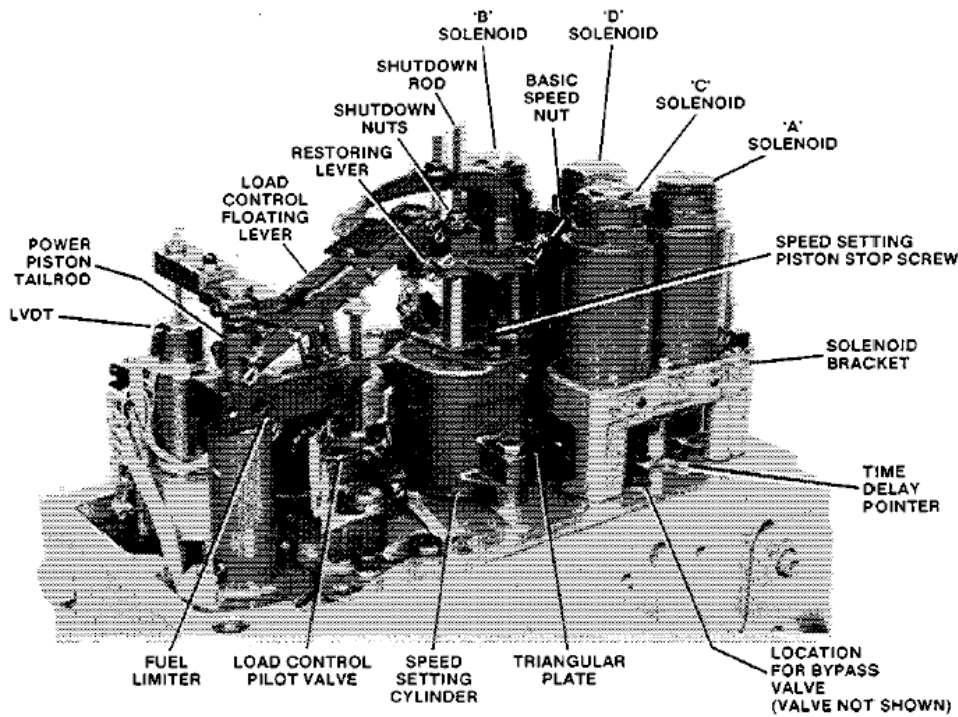

Figure 6-5. Solenoid Pack

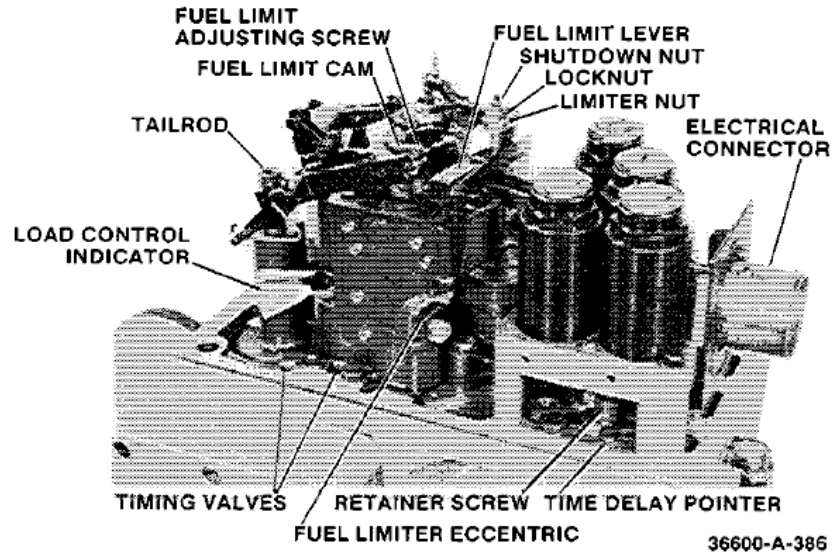

Figure 6-6. PGEV

## Chapter 7. Replacement Parts

This chapter provides replacement parts information for the PGE and PGEV governors.

When ordering replacement parts, include the following information:

- Governor serial number and part number shown on nameplate
- Manual number (this manual 36703)
- Parts reference number in parts list and description of part or part name

### Parts List for Figure 7-1

Ref. No.	Part Name .....	Quantity	Ref. No.	Part Name .....	Quantity
36703-1	Screw, hex hd., drilled, 5/16-24 x 7-1/4 .....	2	36703-37	"D" solenoid cup.....	1
36703-2	Plain washer, 5/16 x 1/2 x 1/32 .....	2	36703-38	Straight pin, 0.1245 x 9/16 .....	1
36703-3	Oil filler cup (Press-fit).....	1	36703-39	Floating lever (Speed setting).....	1
36703-4	Cover dowel bushing (Press-fit) .....	1	36703-40	Thrust bearing.....	1
36703-5	Cover .....	1	36703-41	Pilot valve plunger (speed setting).....	1
36703-6	Cover gasket.....	1	36703-42	Loading spring (SS PV plunger) .....	1
36703-7	Screw, soc. hd., 1/4-28 x 2-3/8.....	3	36703-43	Rotating bushing (SS PV plunger) .....	1
36703-8	Lock washer, split, 1/4.....	3	36703-44	Loading spring (SS PV bushing).....	1
36703-9	Electrical receiver assy (see Fig. 7-16) .....	1	36703-45	Drive gear (SS PV bushing).....	1
36703-10	Nut (Shutdown), 8-32 .....	2	36703-46	Start Fuel Limit Lever failure shutdown.....	1
36703-11	Cotter pin, 1/16 x 3/8.....	1	36703-47	Int. vane servo (see Fig. 7-11 or 7-12).....	1
36703-11A	Plain washer, 13/64 x 3/8 x 0.0501 .....	1	36703-48	Not Used	
36703-12	Headed pin, 3/16 x 61/64 .....	1	36703-49	Setscrew, soc. hd., cup pt., 1/4-28 x 1/4 (Plug).....	AR
36703-13	Screw hex. hd., Grade 5, 5/16-24 x 5.....	4	36703-50	Not Used.....	AR
36703-14	Lock washer, split, 5/16.....	4	36703-51	Union, 3/8-18 NPTF-to-3/8 or 1/2" tube ...	AR
36703-15	Cotter pin, 1/16 x 3/8.....	1	36703-52	Pipe plug, soc. hd. 1/8-27 NPTF.....	AR
36703-15A	Plain washer, 13/64 x 3/8 x 0.050 .....	1	36703-53	Bearing stud (Drive gear) Press-fit.....	1
36703-16	Headed pin, 3/16 x 61/64 .....	1	36703-54	Thread insert, 5/16-24 x 5/8, mid-grip.....	2
36703-17	Screw hex. hd., 1/4-28 x 1.....	2	36703-55	Screw, phil. bdg. hd., 8-32 x 1/4 or #2 x 3/16 drive screw.....	AR
36703-18	Lock washer, split, 1/4.....	2	36703-56	Nameplate .....	1
36703-19	Ld ctrl pilot valve assy (see Fig. 7-10).....	1	36703-57	Screw, phil. rd. hd., 5-40 x 1/4 .....	AR
36703-20	Performed packing (O-ring), 3/8 OD .....	1	36703-58	Nameplate insert.....	AR
36703-21	Oil Seal (used with rem. Id reg. apps).....	1	36703-59	Column sub-assy (includes item 54).....	1
36703-22	Spacer (used with integral Id reg. apps).....	1	36703-60	Gasket (Column/Case) .....	1
36703-23	Gasket (Oil seal/spacer).....	1	36703-61	Seal ring.....	1
36703-24	Loading spring (Load control bushing).....	1	36703-62	LVDT (Linear Variable Differential Transformer).....	1
36703-25	Load control bushing.....	1	36703-63	Screw, soc. hd., 3/8-16 x 1 .....	4
36703-26	Retaining ring, internal .....	1	36703-64	Lock washer, split, 3/8 .....	4
36703-27	Cotter pin, 1/16 x 3/8.....	2	36703-65	Power servo assy (12 ft-lb, spring return reciprocating motion w/tailrod) (see manual 36692) .....	1
36703-28	Straight pin, drilled, 1/8 x 47/64.....	1	36703-66	LVDT mtg. brkt.....	1
36703-29	Screw, hex. hd., 1/4-28 x 1-3/8 .....	2	36703-67	Gasket (Power cylinder/case) .....	1
36703-30	Plain washer, 1/4.....	2	36703-68	Screw, hex. hd., 5/16-18 x 1 .....	8
36703-31	Triangular plate .....	1	36703-69	Lock washer, split, 5/16 .....	8
36703-32	Spd setting servo assy (see Fig. 7-13).....	1	36703-70	Base assy (Std. PG) (see manual 36693)...	1
36703-33	Return spring (Speed setting piston).....	1	36703-71	Oil seal (Preformed).....	1
36703-34	Performed packing 3/8 OD.....	1	36703-72	Power case assy (see manual 36600 .....	1
36703-34A	Solenoid counterbalance spring .....	1			
36703-35	Bypass valve assy (Engine lube oil pressure failure shutdown- see manual 36652 .....	1			
36703-35A	Retainer screw .....	1			
36703-35B	Plain washer, 1/4.....	1			
36703-36	Time delay mechanism (Engine lube oil pressure failure shutdown- see Manual 36652).....	1			

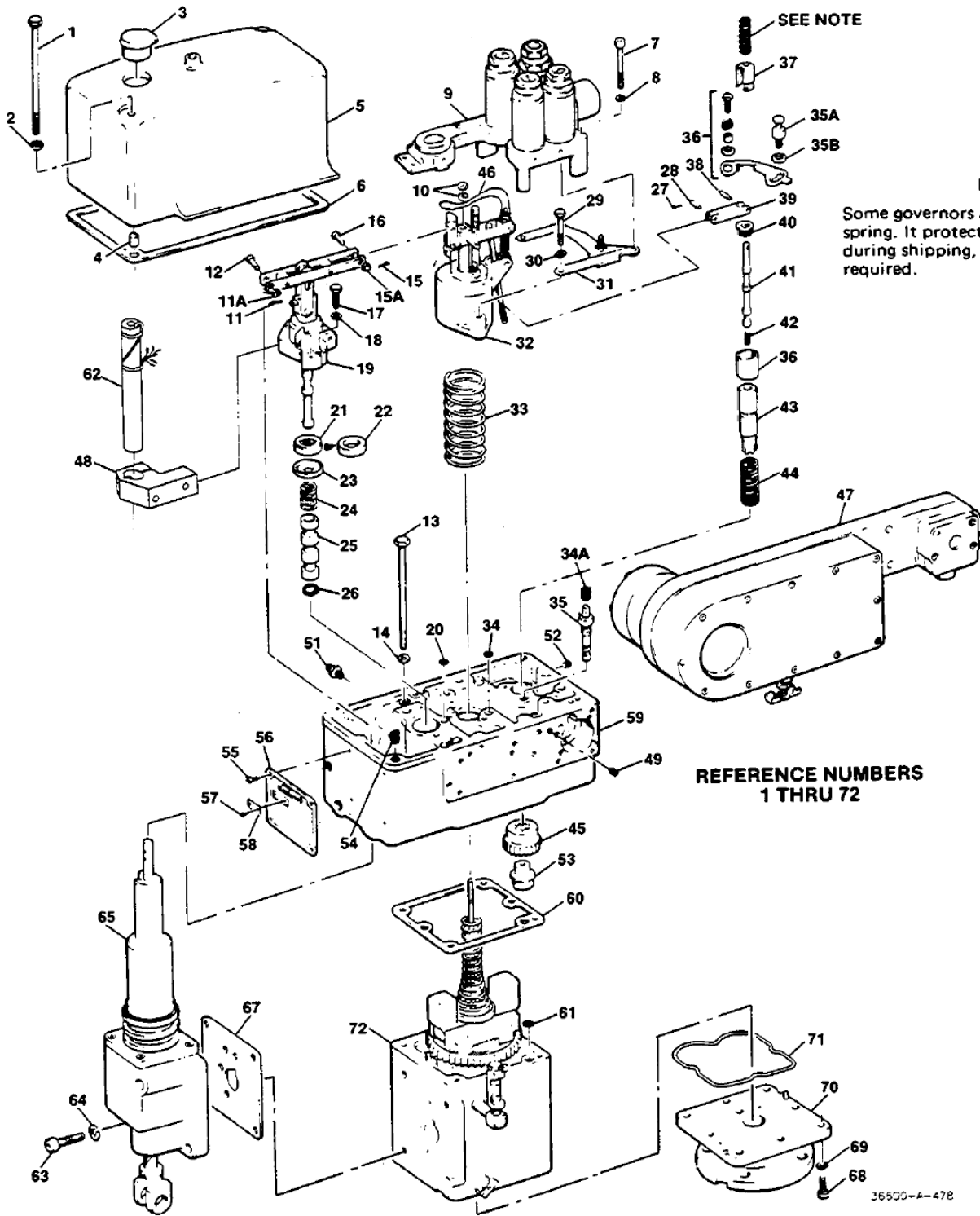

Figure 7-1. Exploded View of PGEV Governor Assembly (8571-882 Type)

Parts List for Figure 7-2

Ref. No.	Part Name	Quantity	Ref. No.	Part Name	Quantity
36703-126	Screw, hex., hd., drilled, 5/16-24 x 7-1/4	2	36703-166	Time delay mechanism (Engine lube oil pressure failure shutdown- see manual 36652)	1
36703-127	Plain washer, 5/16 x 1/2 x 1/32	2	36703-167	"D" solenoid cup	1
36703-128	Oil filler cup (Press-fit)	1	36703-168	Straight pin, 0.1245 x 9/16	1
36703-129	Cover dowel bushing (Press-fit)	1	36703-169	Floating lever (Speed setting)	1
36703-130	Cover	1	36703-170	Thrust bearing	1
36703-131	Cover gasket	1	36703-171	Pilot valve plunger (Speed setting)	1
36703-132	Screw, soc. hd., 1/4-28 x 2-3/8	3	36703-172	Loading spring (SS PV plunger)	1
36703-133	Lock washer, split, 1/4	3	36703-173	Rotating bushing (SS PV plunger)	1
36703-134	Electrical receiver assy (see Fig. 7-16)	1	36703-174	Loading spring (SS PV bushing)	1
36703-135	Nut (Shutdown), 8-32	2	36703-175	Drive gear (SS PV bushing)	1
36703-136	Cotter pin, 1/16 x 3/8	1	36703-176	Not Used	
36703-137	Lever and Linkage Assy	1	36703-177	Integral vane servo (see Fig. 7-11 or 7-12)	1
36703-138	Headed pin, 3/16 x 61/64	1	36703-178	Lube oil time delay accum.	1
36703-139	Screw hex hd. Grade 5, 5/16-24 x 5	4	36703-179	Setscrew, soc. hd., cup pt., 1/4-28 x 1/4 (plug)	AR
36703-140	Lock washer, split, 5/16	4	36703-180	Not Used	
36703-141	Cotter pin, 1/16 x 3/8	1	36703-181	Union, 3/8-18 NPTF-to-3/8 or 1/2" tube	AR
36703-142	Special Washer	1	36703-182	Pipe plug, soc. hd. 1/8-27 NPTF	AR
36703-143	Headed pin, 3/16 x 61/64	1	36703-183	Bearing stud (Drive gear) Press-fit	1
36703-144	Screw hex. hd., 1/4-28 x 1	2	36703-184	Thread insert, 5/16-24 x 5/8, mid-grip	2
36703-145	Lock washer, split, 1/4	2	36703-185	Screw, phil. bdg. hd., 8-32 x 1/4 or #2 x 3/16 drive screw	AR
36703-146	Load control pilot valve assy (see Fig. 7-10)	1	36703-186	Nameplate	1
36703-147	Performed packing (O-ring), 3/8 OD	1	36703-187	Screw, phil. rd. hd., 5-40 x 1/4	AR
36703-148	Oil Seal (used with remote load regulator applications)	1	36703-188	Nameplate insert	AR
36703-149	Spacer (used with integral load regulator applications)	1	36703-189	Column sub-assy (includes item 184)	1
36703-150	Gasket (oil seal/spacer)	1	36703-190	Gasket (Column/Case)	1
36703-151	Loading spring (load control bushing)	1	36703-191	Seal ring	1
36703-152	Load control bushing	1	36703-192	Not Used	
36703-153	Retaining ring, internal	1	36703-193	Not Used	
36703-154	Cotter pin, 1/16 x 3/8	2	36703-194	Not Used	
36703-155	Straight pin, drilled, 1/8 x 47/64	1	36703-195	Not Used	
36703-156	Screw, hex. hd., 1/4-28 x 1-3/8	2	36703-196	Power servo assy (12 ft-lb spring-return rotary motion w/tailrod) (see manual 36692)	1
36703-157	Plain washer, 1/4	2	36703-197	Gasket (Power cylinder/case)	1
36703-158	Triangular plate	1	36703-198	Screw, hex. hd., 5/16-18 x 1	8
36703-159	Speed setting servo assy (see Fig. 7-13)	1	36703-199	Lock washer, split, 5/16	8
36703-160	Return spring (Speed setting piston)	1	36703-200	Base assy (Std. PG) (see manual 36693)	1
36703-161	Performed packing 3/8 OD	1	36703-201	Oil seal (Preformed)	1
36703-162	Solenoid counterbalance spring	1	36703-202	Power case assy (see manual 36600)	1
36703-163	Bypass valve assy (Engine lube oil pressure failure shutdown- see manual 36652)	1			
36703-164	Retainer screw	1			
36703-165	Plain washer, 1/4	1			

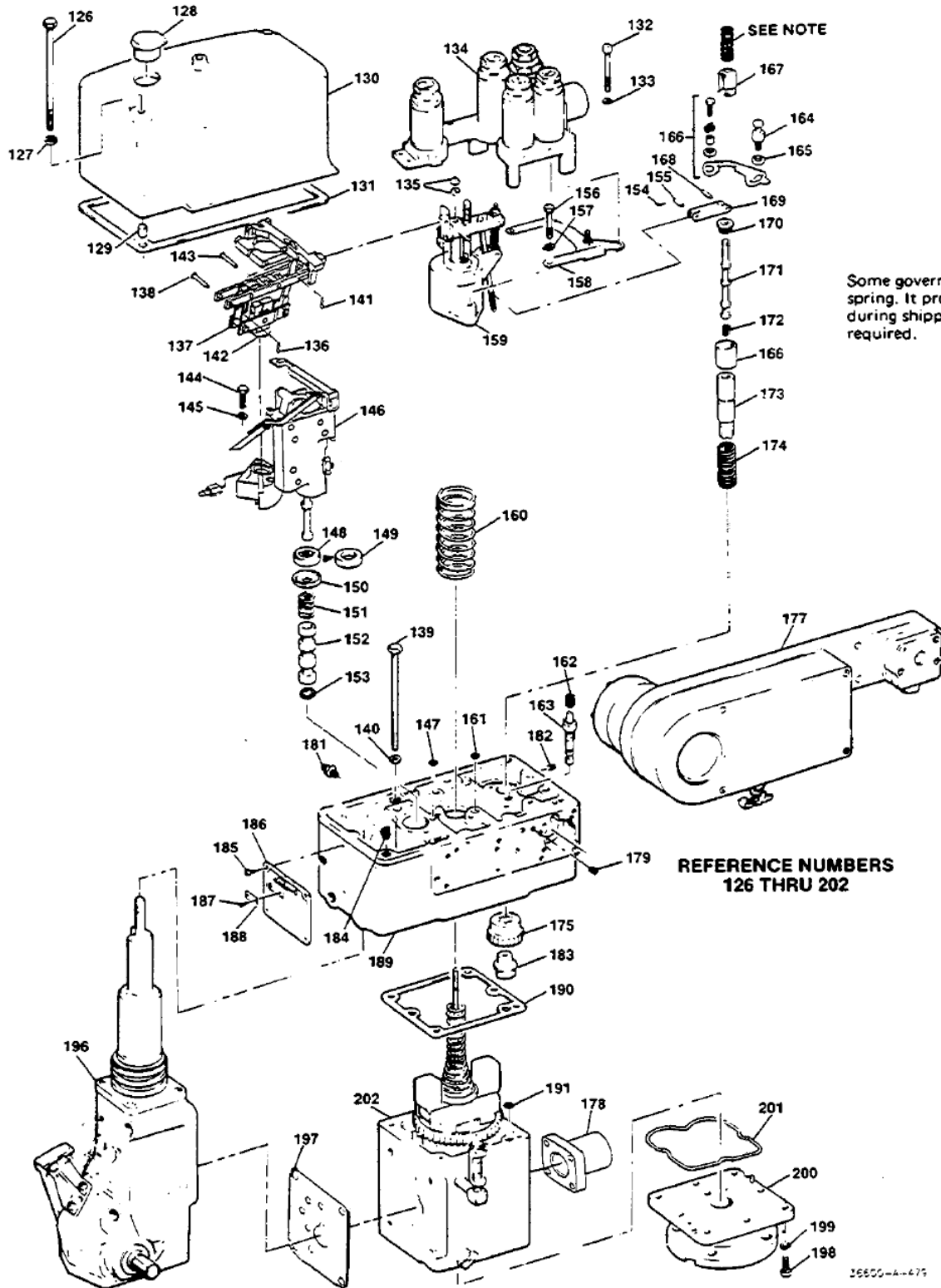

Figure 7-2. Exploded View of PGEV Governor Assembly (8571-561 Type)

**Parts List for Figure 7-3**

<b>Ref. No.</b>	<b>Part Name</b> .....	<b>Quantity</b>	<b>Ref. No.</b>	<b>Part Name</b> .....	<b>Quantity</b>
36703-251	Idler gear .....	1	36703-279	Thrust bearing .....	1
36703-252	Idler gear stud .....	1	36703-280	Nut 8-32, reduced hex .....	1
36703-253	Snap ring .....	4	36703-281	Jam nut, hex., 5/16-24 .....	1
36703-254	Drain cock .....	1	36703-282	Nut, hex. .312-24 .....	1
36703-255	Elbow .....	1	36703-283	Bushing, shutdown .....	1
36703-256	Oil level gauge .....	1	36703-284	Shutdown rod .....	1
36703-257	Pipe plug, 1/8 in. ....	7	36703-285	Adjusting spring washer .....	1
36703-258	Drive gear .....	1	36703-286	Adjusting spring .....	1
36703-259	Accumulator piston .....	2	36703-287	Flyweight .....	2
36703-260	Check plug .....	2	36703-288	Flyweight bearing .....	4
36703-261	Power case .....	1	36703-289	Screw, rd. hd., split, 8-32 x 5/16 .....	1
36703-262	Case-to-column dowel pin .....	2	36703-290	Lockwasher, split, No. 8 .....	1
36703-263	Accumulator spring (small) .....	2	36703-291	Spring coupling assembly .....	1
36703-264	Spring seat .....	2	36703-292	Screw, fil. hd. 5-40 x 9/32 .....	8
36703-265	Accumulator spring (large) .....	2	36703-293	Lock washer, No. 5 .....	8
36703-266	Gasket .....	1	36703-294	Flyweight head .....	1
36703-267	Spring seat .....	1	36703-295	Flyweight pin - limit pin .....	4
36703-268	Buffer springs .....	2	36703-296	Cotter pin .....	8
36703-269	Plug .....	1	36703-297	Snap ring .....	1
36703-270	O-Ring .....	1	36703-298	Compensating bushing .....	1
36703-271	Snap ring .....	1	36703-299	Pilot valve plunger .....	1
36703-272	Buffer piston .....	1	36703-300	Centering bearing .....	1
36703-273	Speeder spring check plug .....	1	36703-301	Oil seal ring .....	1
36703-274	Speeder spring .....	1	36703-302	Flyweight head gear .....	1
36703-275	Pilot valve plunger nut .....	1	36703-303	Pipe plug, 1/16 .....	5
36703-276	Cotter pin .....	1	36703-304	O-ring .....	1
36703-277	Spring .....	1	36703-305	Loading Spring (Pilot Valve) .....	1
36703-278	Speeder spring seat .....	1	36703-306 to 360	Not Used	

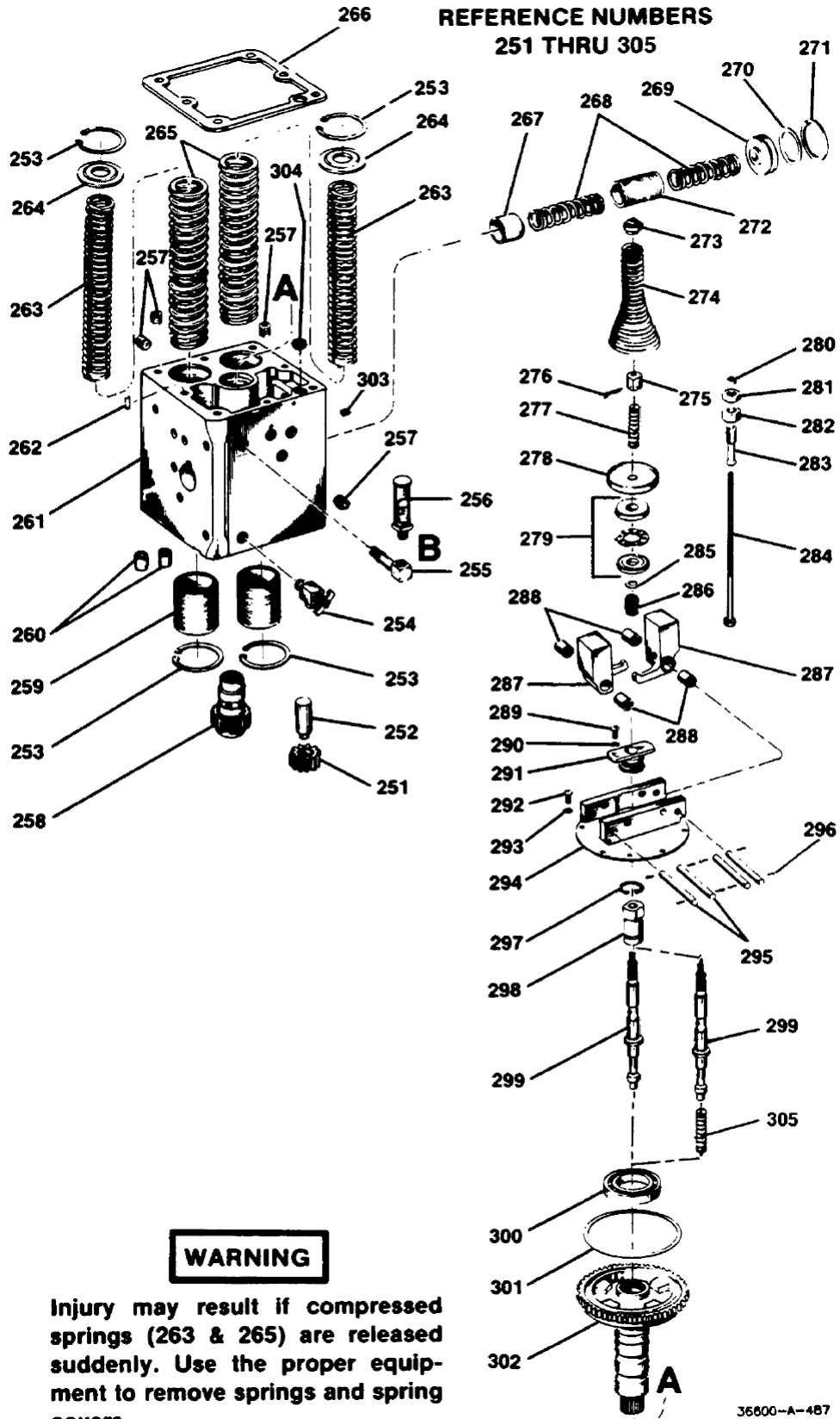

Figure 7-3. Exploded View of Power Case and Pilot Valve Assembly

Parts List for Figure 7-4

Ref. No.	Part Name.....	Quantity
36703-361	Base .....	1
36703-362	Seal .....	1
36703-363	Bearing .....	1
36703-364	Shaft .....	1
36703-365	Pin .....	2
36703-366	Screw, cap, hex. hd., 5/16-18 x 1 .....	8
36703-367	Bearing Retainer .....	1
36703-368	Screw, cap, hex. hd., 1/4-28 x 5/8 .....	3
36703-369 to 400	Not Used	

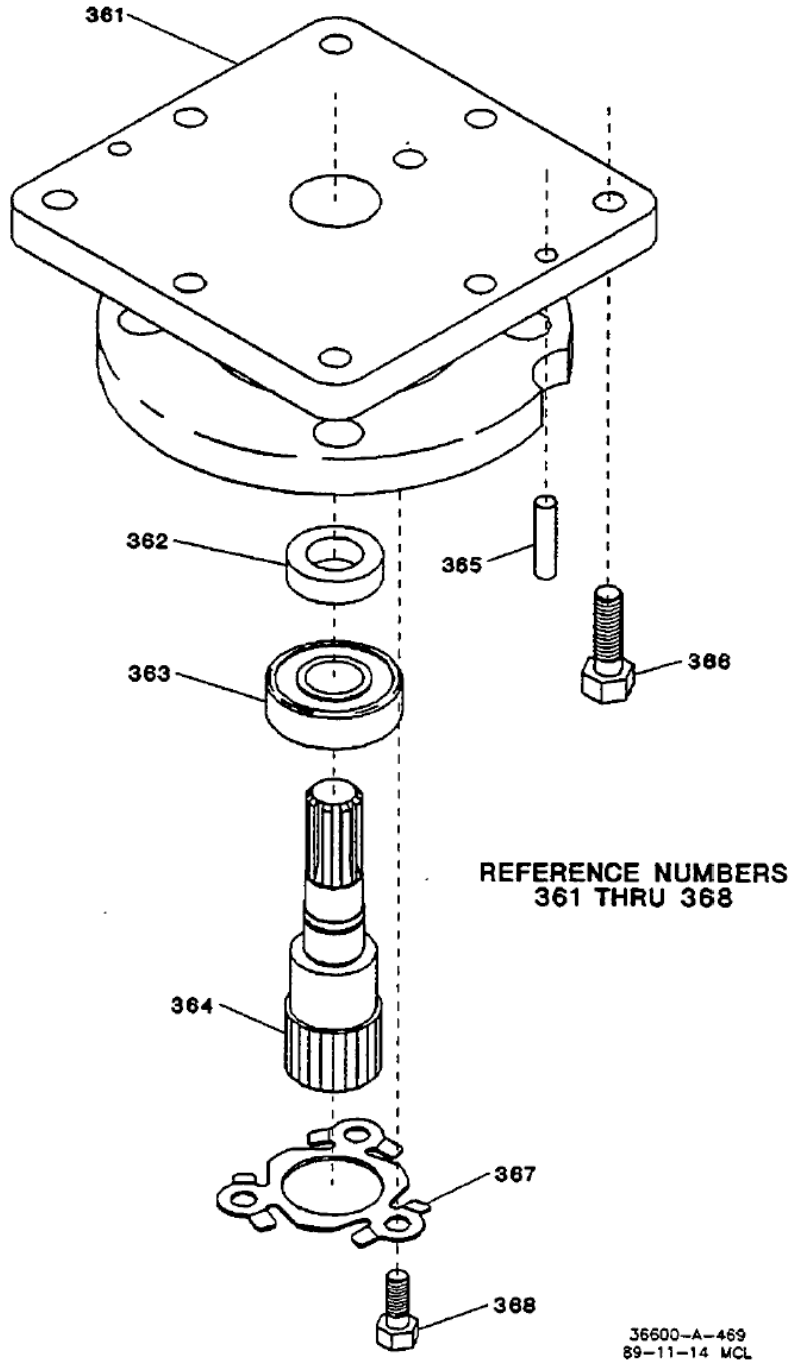

Figure 7-4. Exploded View of Standard Base

Parts List for Figure 7-5

Ref. No.	Part Name	Quantity	Ref. No.	Part Name	Quantity
36703-401	O-Ring	1	36703-414	Nut, tailrod, flex-loc, 3/8-24	1
36703-402	Ring, spring guard seal	1	36703-415	Nut, tailrod, lift	1
36703-403	Spring, spring guard seal	1	36703-416	Washer, shake-proof, 3/8	1
36703-404	Screw, fil. hd., 10-32 x 3/8	2	36703-417	Power piston and rod assembly	1
36703-405	Washer, No. 10	2	36703-418	Valve, needle	1
36703-406	Scale, piston gap	1	36703-419	O-ring	1
36703-407	Screw, cap, soc. hd., 1/4-28 x 1/2	4	36703-420	Power cylinder assembly	1
36703-408	Washer, shake-proof, 1/4	1	36703-421	Seal, oil, type P	1
36703-409	Spring guard	1	36703-422	Seal, oil, type G	1
36703-410	Gasket, spring guard	1	36703-423	Pin, taper	1
36703-411	Spring, power	1	36703-424	Pin, cotter, 1/16 x 3/8	1
36703-412	Pin, fuel indicator	1	36703-425	Rod end	1
36703-413	Tailrod, power piston	1	36703-426	through 450 Not used	1

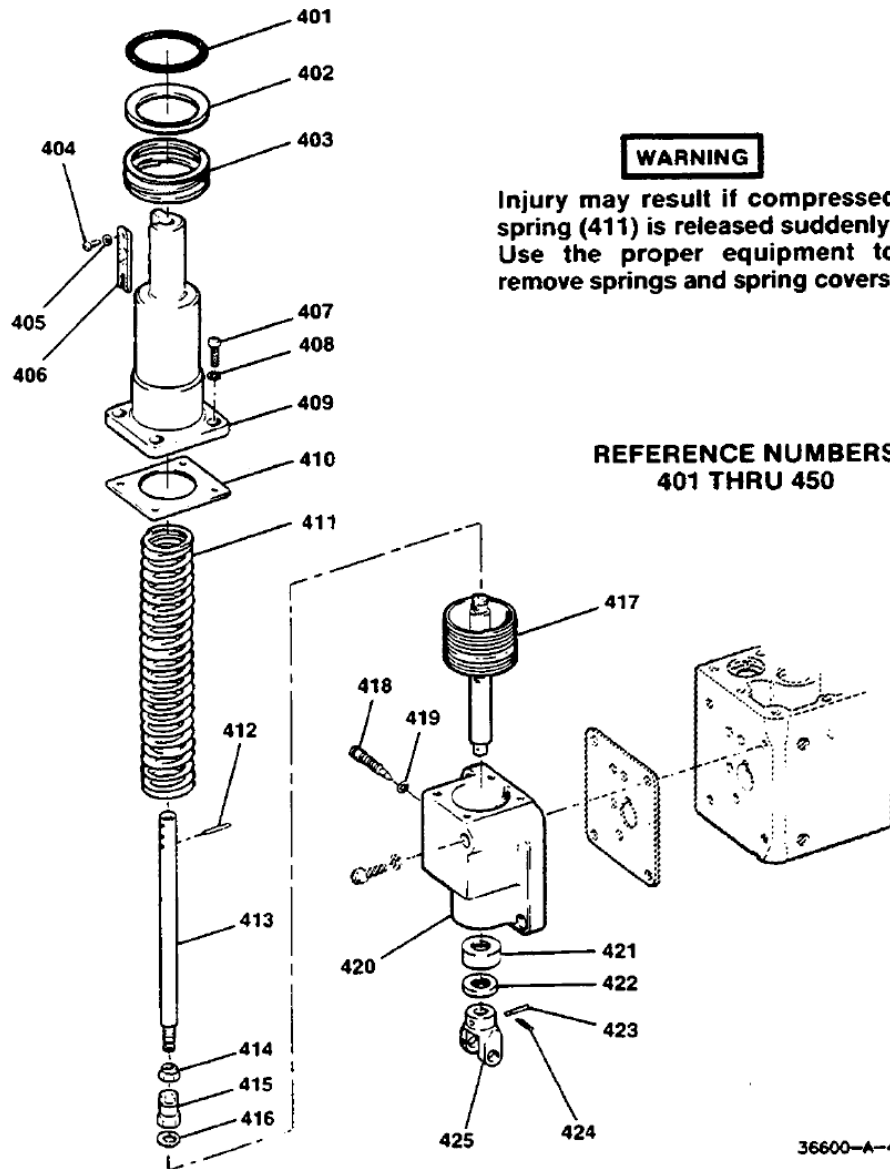

Figure 7-5. Exploded View of Linear Power Servo

**Parts List for Figure 7-6**

<b>Ref. No.</b>	<b>Part Name .....</b>	<b>Quantity</b>	<b>Ref. No.</b>	<b>Part Name .....</b>	<b>Quantity</b>
36703-451	Power Cylinder.....	1	36703-471	Power Piston Link .....	1
36703-452	Not Used .....		36703-472	External Retaining Ring .338 Free Diameter .....	1
36703-453	Screw, Locking Rd. Hd. Ph., 8-32 x 3/8 .....	1	36703-473	Needle Bearing, ID .688, OD .875, Length .75.....	1
36703-454	Pointer.....	1	36703-474	Piston Rod Pin .....	1
36703-455	Pointer Bracket .....	1	36703-475	Nut, Elastic Hex, 7/16-20 .....	1
36703-456	Screw, Socket Hd. Cap, 1/4-28 x 5/8 .....	2	36703-476	Power Lever Pin.....	1
36703-457	Washer, Flat, ID.265, OD .42 x .06 .....	2	36703-477	Screw, Socket Hd. Cap, 5/16- 18 x .875 .....	2
36703-458	Screw, U Drive 2 x 3/16 .....	2	36703-478	Lockwasher, High Collar, 5/16 .....	2
36703-459	Terminal Shaft Scale.....	1	36703-479	Power Lever Assembly .....	1
36703-460	Rack Dial Lever.....	1	36703-480	Power Piston Link .....	1
36703-461	Screw, Socket Head Cap, 1/4- 28 x 1 .....	1	36703-481	External Retaining Ring .693 Free Diameter .....	1
36703-462	Needle Valve.....	1	36703-482	External Retaining Ring .338 Free Diameter .....	1
36703-463	Preformed Packing.....	1	36703-483	Power Cylinder to Cover Gasket.....	1
36703-464	Oil Seal .....	1	36703-484	Power Cylinder Cover .....	1
36703-465	Screw, Socket Hd. Cap, 3/8-16 x 1 .....	4	36703-485	Washer, Flat, ID .266, OD .421, .06 Thick ..8	
36703-466	Lockwasher, High Collar, 3/8 .....	4	36703-486	Screw, Socket Hd. Cap 1/4-28 x .75 .....	8
36703-467	Serrated Terminal Shaft .....	1	36703-487	through 500 Not used	
36703-468	Needle Bearing, ID .812, OD 1.062, Length .875 .....	1			
36703-469	Oil Seal .....	1			
36703-470	External Retaining Ring .693 Free Diameter .....	1			

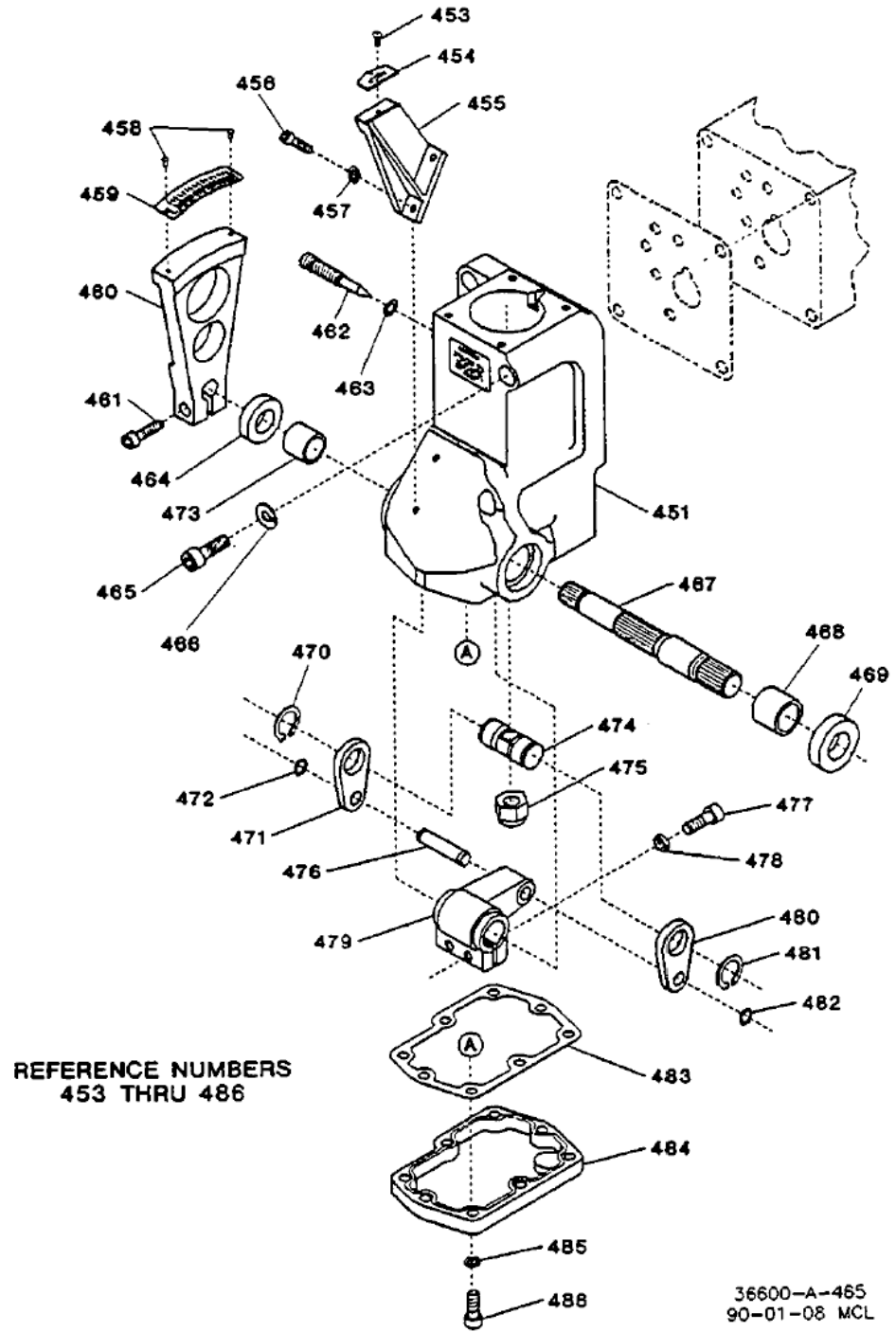

Figure 7-6. Exploded View of Rotary Power Servo

Parts List for Figure 7-7

Ref. No.	Part Name	Quantity	Ref. No.	Part Name	Quantity
36703-501	Not Used		36703-516	O-ring 2.012 OD	1
36703-502	Union Assy - limiter bulkhead	1	36703-517	Bellofram spacer	1
36703-503	Lock-nut, Union assembly	1	36703-518	Diaphragm	1
36703-504	Screw - Type U drive, 6 x 3/8	1	36703-519	Diaphragm washer	1
36703-505	Plug	1	36703-520	Nut, hex, 10-32 (special)	1
36703-506	Piston spring	1	36703-521	Load spring	1
36703-507	Shutdown piston	1	36703-522	Spring seat (adjustment screw)	1
36703-508	Valve bushing gasket	1	36703-523	O-ring, 2.0 12 OD	1
36703-509	Valve bushing	1	36703-524	Diaphragm cap	1
36703-510	Washer	1	36703-525	Plug	1
36703-511	Screw, soc. hd., 1/4-28 x 3/8	1	36703-526	Washer, split lock, 17/64	4
36703-512	Shutdown valve plunger	1	36703-527	Screw, soc. hd., 1/4-28 x 2	4
36703-513	Diaphragm	1	36703-528	Plunger	1
36703-514	Differential piston		36703-529	through 550 Not Used	
36703-515	O-ring, .316 OD	1			

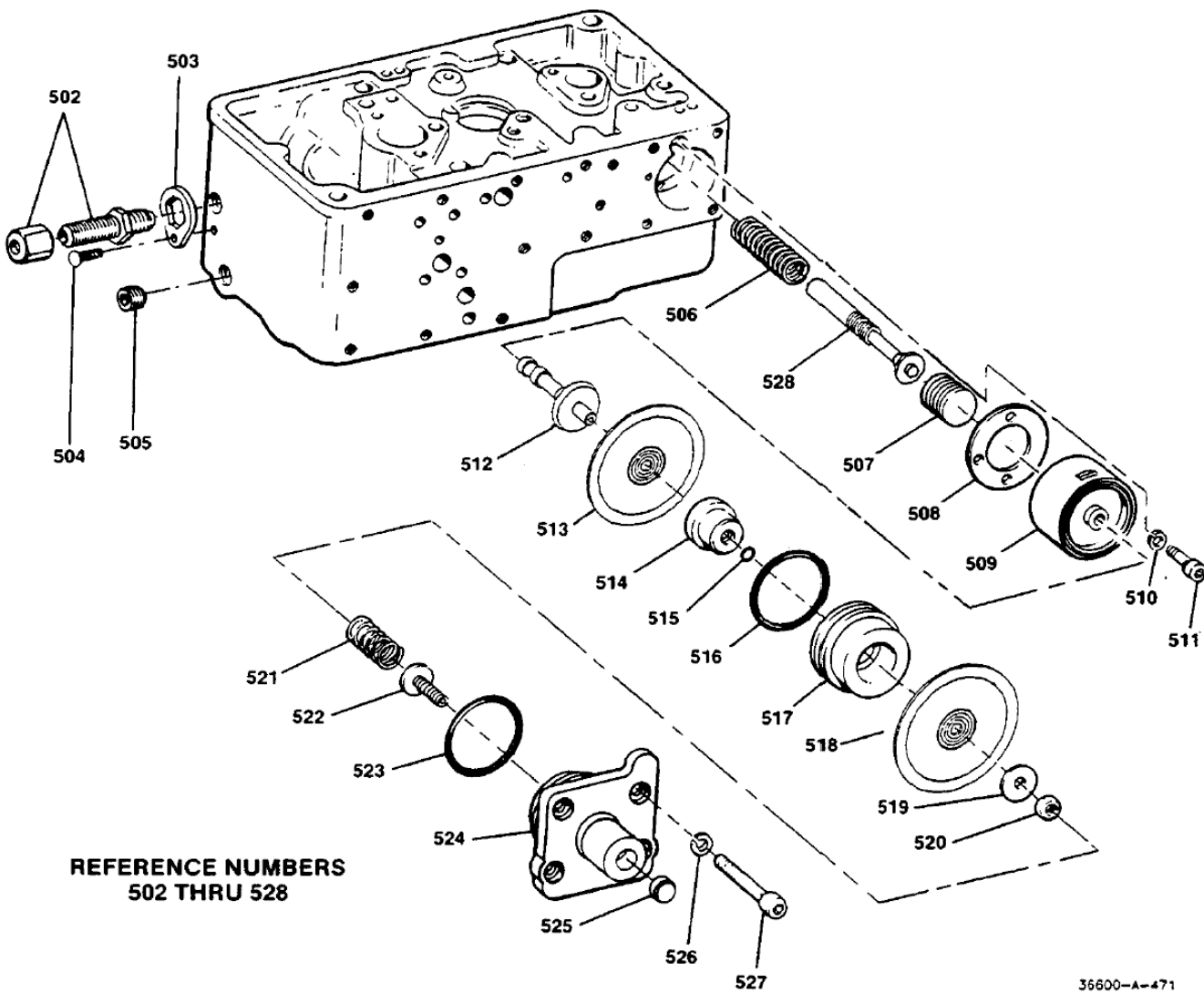

Figure 7-7. Exploded View of Differential Area Lube Oil Shutdown

Parts List for Figure 7-8

Ref. No.	Part Name	Quantity	Ref. No.	Part Name	Quantity
36703-551	Not Used		36703-563	Diaphragm	1
36703-552	Union Assy - limiter bulkhead	1	36703-564	Diaphragm washer	1
36703-553	Lock-nut, Union assembly	1	36703-565	Nut, hex, 10-32 (special)	1
36703-554	Screw - Type U drive, 6 x 3/8	1	36703-566	Load spring	1
36703-555	Plug	1	36703-567	Spring seat (adjustment screw)	1
36703-556	Piston spring	1	36703-568	O-ring, 2.0 12 OD	1
36703-557	Shutdown piston	1	36703-569	Diaphragm cap	1
36703-558	Valve bushing gasket	1	36703-570	Plug	1
36703-559	Valve bushing	1	36703-571	Washer, split lock, 17/64	4
36703-560	Washer	1	36703-572	Screw, soc. hd., 1/4-28 x 2	4
36703-561	Screw, soc. hd., 1/4-28 x 3/8	1	36703-573	Plunger	1
36703-562	Shutdown valve plunger	1	36703-574	through 609 Not Used	

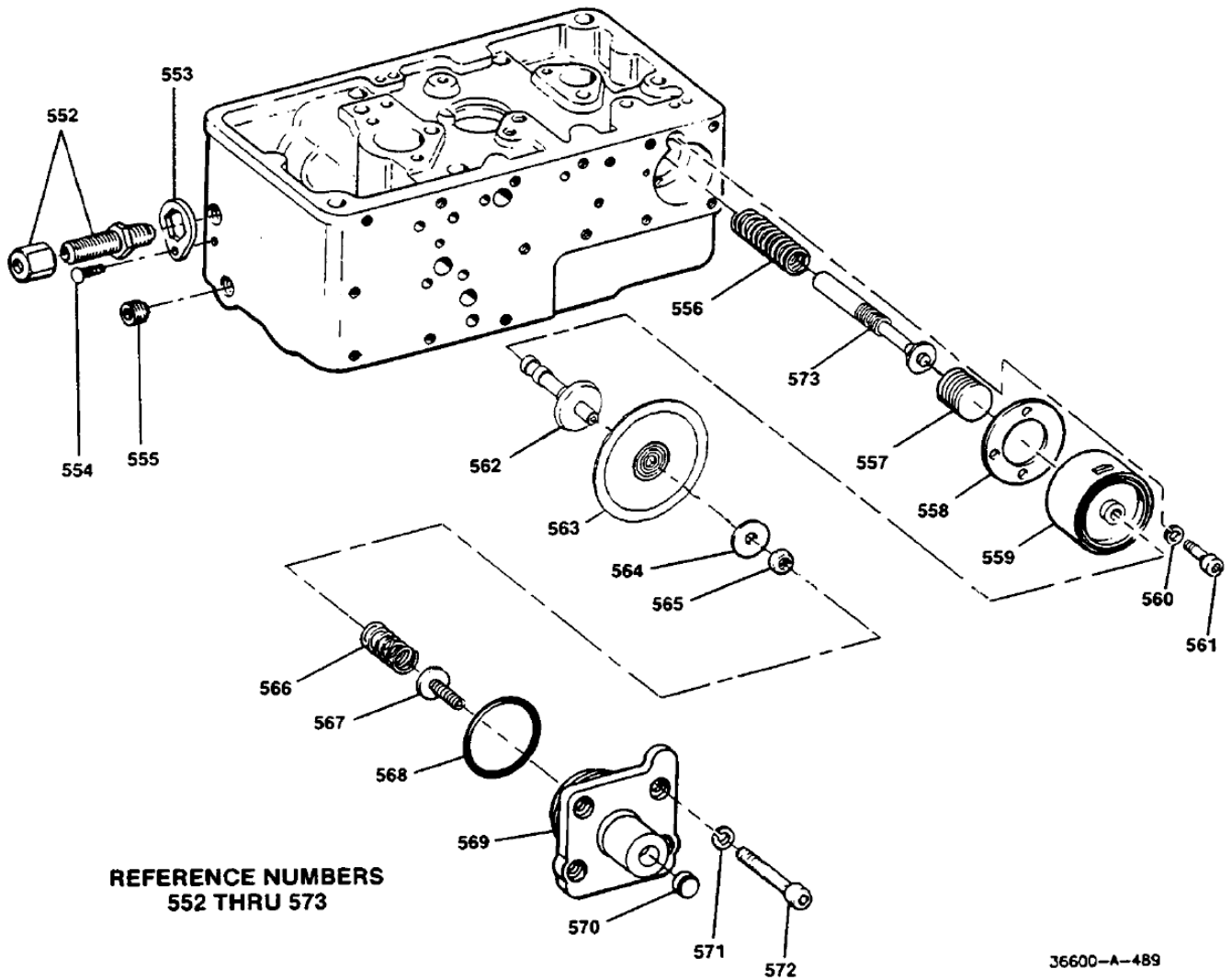

Figure 7-8. Exploded View of Low Lube Oil Shutdown

Parts List for Figure 7-9

Ref. No.	Part Name	Quantity	Ref. No.	Part Name	Quantity
36703-601	through 609	Not Used	36703-619	Nut, seal retainer	1
36703-610	O-ring	1	36703-620	Counterbalance spring (solenoid speed setting only)	1
36703-611	Bypass valve spring seat	1	36703-621	Adjustment sleeve	1
36703-612	Bypass valve spring	1	36703-622	Time delay pointer	1
36703-613	Bypass valve plunger	1	36703-623	Retainer spring washer	1
36703-614	Roll pin	1	36703-624	Retainer spring collar	1
36703-615	Bypass valve body	1	36703-625	Bushing retainer spring	1
36703-616	Retainer spring	1	36703-626	Screw, hex. hd., 1/4-28 x 3/4	1
36703-617	Retainer sleeve	1	36703-627	through 700	Not used
36703-618	O-ring	1			

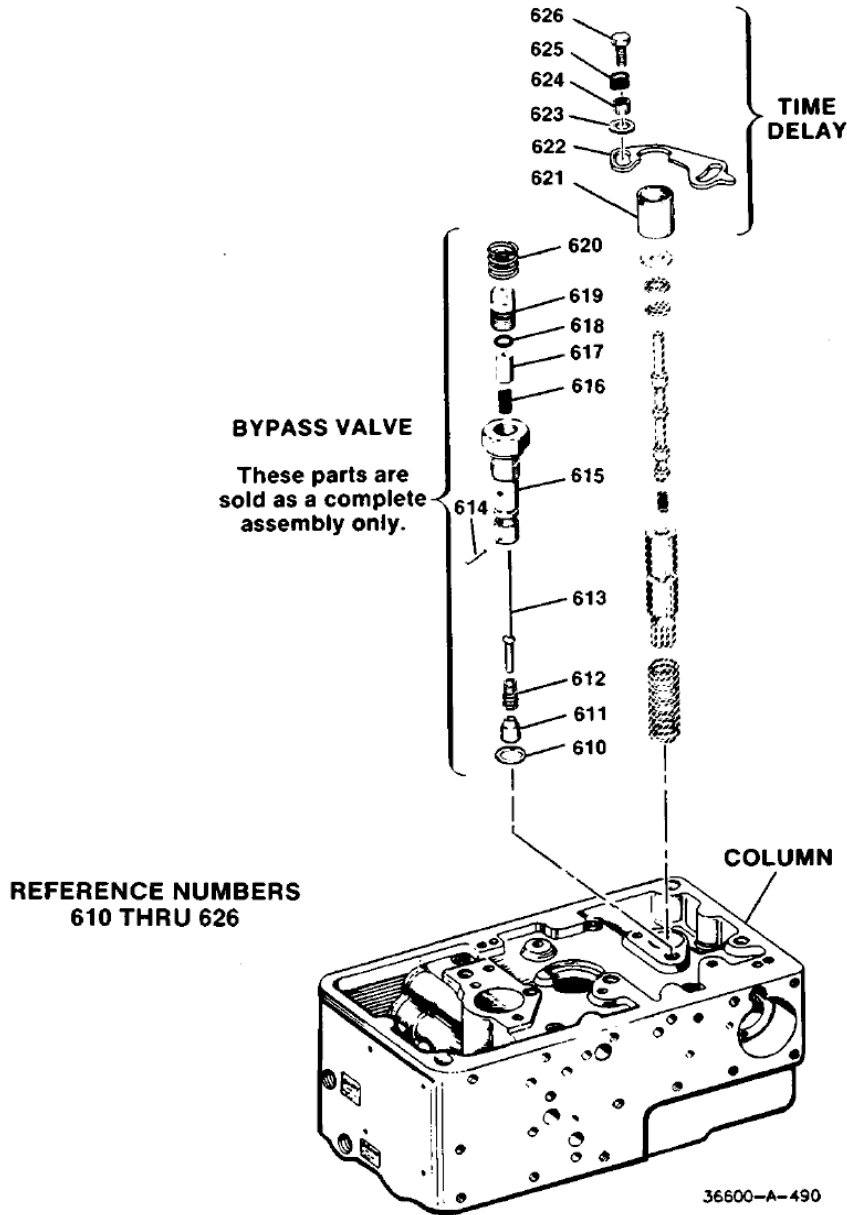

Figure 7-9. Exploded View of Time Delay and Bypass Valve

Parts List for Figure 7-10

Ref. No.	Part Name	Quantity
36703-701	Overriding valve plunger	1
36703-702	Return spring Overriding valve plunger	1
36703-703	Screw, phil. rd. hd., 10-32 x 1/4	1
36703-704	Plain washer, #10	1
36703-705	Load control indicator assy	1
36703-706	Cotter pin, 1/16 x 1/2	1
36703-707	Knob pin	1
36703-708	Knob	1
36703-709	Knob spring	1
36703-710	Range adjustment screw	1
36703-711	Load control floating lever	1
36703-712	Cotter pin, 1/16 x 3/8	2
36703-713	Load control link	2
36703-714	Fulcrum block (Load control)	1
36703-715	Screw, soc. hd., 1/4-28 x 3/4	1
36703-716	Eccentric	1
36703-717	Connecting block	1
36703-718	Indicator actuating washer	1
36703-719	Nut, 5/16-24	1
36703-720	Retaining ring	1
36703-721	Spring retainer	1
36703-722	Load control spring Outer	1
36703-723	Load control spring (Inner)	1
36703-724	Nut, 5/16-24	1
36703-725	Spring collar	1
36703-726	Pilot valve plunger (Load control)	1
36703-727	Overriding piston	1
36703-728	Tapered plug, 1/4-28 (Special)	AR
36703-729	Cylinder head (Press-fit)	1
36703-730	Overriding cylinder	1
36703-731	through 740 Not Used	

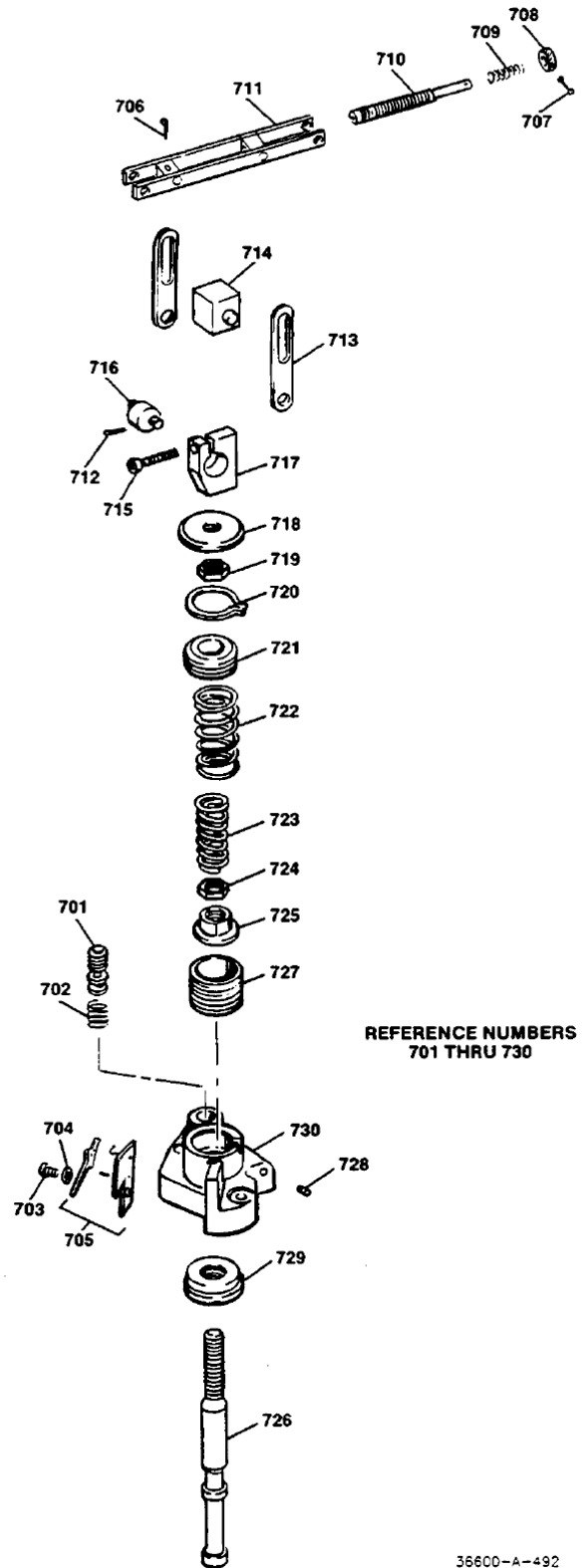
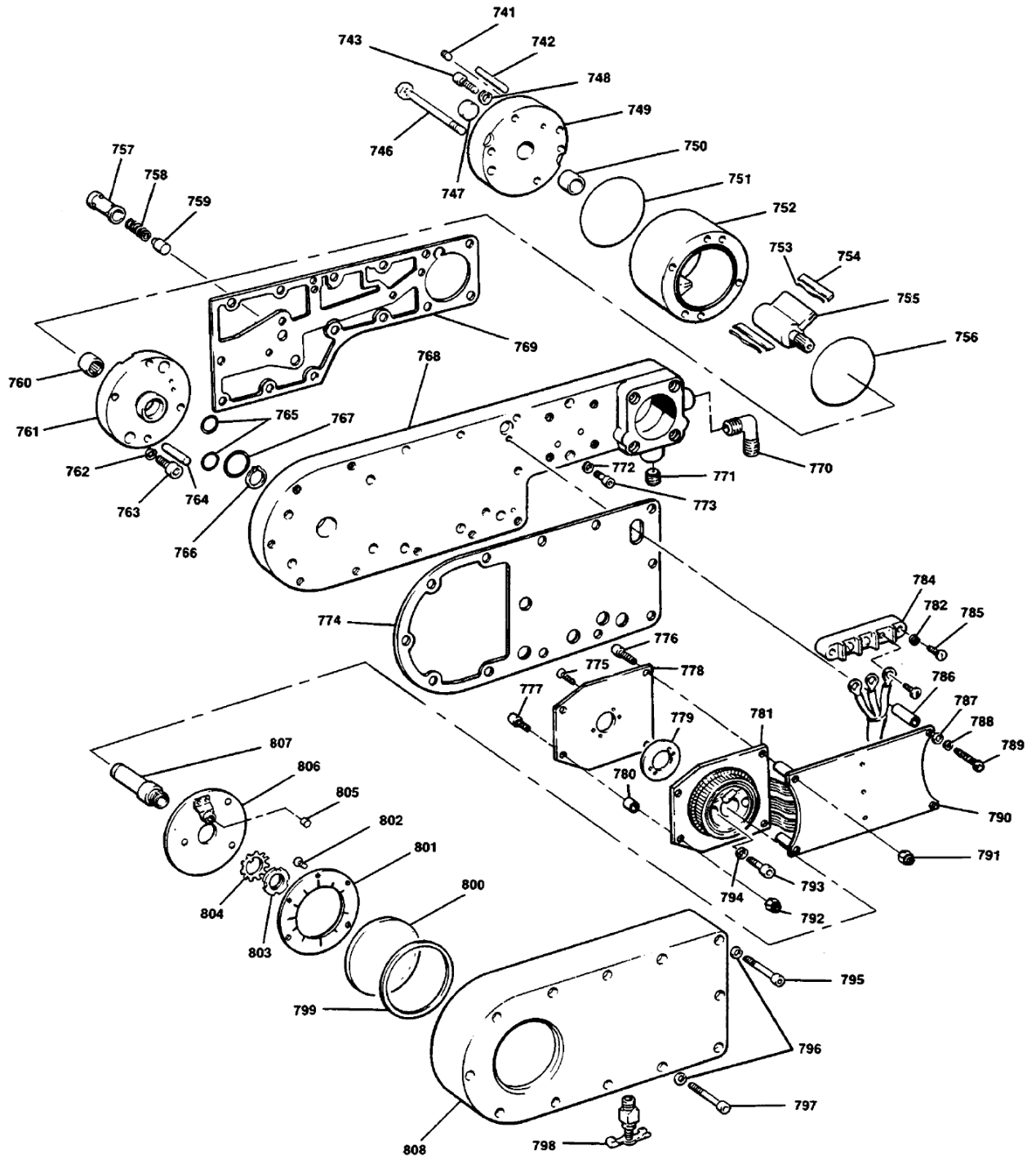

Figure 7-10. Exploded View of Load Control Pilot Valve Assembly

Parts List for Figure 7-11

Ref. No.	Part Name	Quantity	Ref. No.	Part Name	Quantity
36703-741	Pipe plug, soc. hd., 1/8 NPTF	1	36703-776	Screw, fil. hd., 8-32 x .750	2
36703-742	Dowel pin, 1/4 x 1	4	36703-777	Screw, fil. hd., 8-32 x .750	2
36703-743	Screw, soc. hd., 1/4-28 x 1	2	36703-778	Commutator plate	1
36703-744	Nut, 1/4-28	1	36703-779	Spacer	1
36703-745	Lockwasher, int. tooth, 1/4	2	36703-780	Spacer, .375 OD x .203 ID x .250	4
36703-746	Stud	2	36703-781	Lead Wire retainer	1
36703-747	End plate plug	1	36703-782	Lockwasher, No. 6	2
36703-748	Lock washer, split, 1/4	2	36703-783	Fiber washer	2
36703-749	End plate	1	36703-784	Terminal block assembly	1
36703-750	Needle bearing	2	36703-785	Screw, Ph. Pan. Hd., 6-32 x 1/2	2
36703-751	Oil seal ring	1	36703-786	Spacer, resistor pack .437 OD x .031 ID x 1.00	2
36703-752	Housing and divider assy	1	36703-787	Fiber Washer, extruded, insulating	2
36703-753	Insert spring	2	36703-788	Lockwasher, int tooth, No. 8	2
36703-754	Vane insert	2	36703-789	Screw, soc hd, 8-32 x 3/8	2
36703-755	Servomotor shaft	1	36703-790	Commutator and resistor pack assy	1
36703-756	Oil seal ring	1	36703-791	Nut, self-locking, 8-32	2
36703-757	Supply valve sleeve	1	36703-792	Nut, hex., elastic, 8-32	2
36703-758	Supply valve spring	1	36703-793	Screw cap, soc. hd., 8-32 x 1-1/8	2
36703-759	Supply valve plunger (load control)	1	36703-794	Lockwasher, split, No. 8	2
36703-760	Needle bearing	2	36703-795	Screw, soc. hd., 1/4-28 x 3	4
36703-761	Back plate	1	36703-796	Lockwasher, split, 1/4	12
36703-762	Lockwasher, split, 1/4	2	36703-797	Screw, soc. hd., 1/4-28 x 3	8
36703-763	Screw, soc. hd., 1/4-28 x 3/4	2	36703-798	Drain valve	1
36703-764	Pin, straight, 1/4 x 3/4	4	36703-799	Dial glass gasket	1
36703-765	O-ring 11/16 OD	2	36703-800	Dial glass	1
36703-766	Retaining ring, external	1	36703-801	Dial plate	1
36703-767	O-ring	1	36703-802	Screw, Phil. flat hd., 6-32 x 3/8	6
36703-768	Side plate	1	36703-803	Spanner nut	1
36703-769	Side plate gasket	1	36703-804	Keyed lock washer	1
36703-770	Elbow 90	1	36703-805	Indicator button	1
36703-771	Plug, hex. socket .250 18	1	36703-806	Contact brush and indicator assy	1
36703-772	Lockwasher, split, 1/4	1	36703-807	Brush drive shaft	1
36703-773	Screw, soc. hd. 1/4-28 x 3/4	10	36703-808	Cover	1
36703-774	Cover gasket	1	36703-809	through 840	Not used
36703-775	Screw, Ph. flat head., 8-32 x .375	2			



REFERENCE NUMBERS  
741 THRU 808

36600-A-496

Figure 7-11. Exploded View of Vane Servo (Resistor Pack)

**Parts List for Figure 7-12**

Ref. No.	Part Name .....	Quantity	Ref. No.	Part Name .....	Quantity
36703-841	Pipe plug, soc. hd., 1/8 NPTF .....	1	36703-866	Seal .....	1
36703-842	Dowel pin, 1/4 x 1 .....	2	36703-867	Seal Support .....	1
36703-843	Screw, socket hd, cap 10 32 Length 3/8 .....	1	36703-868	Paper Insulator .....	1
36703-844	Washer ID.203, OD.438 x .032 .....	1	36703-869	Wave Washer .....	1
36703-845	Vane Position Pointer .....	1	36703-870	Ceramic Resistor .....	1
36703-846	Double Lip Seal .....	1	36703-871	Clamping Plate .....	1
36703-847	Vane Position Indicator .....	1	36703-872	Screw, Locking Ph. Pan Hd, SS 8-32 Length 1/2 .....	2
36703-848	Screw, socket hd., cap, 1/4-28 x .625 .....	2	36703-873	Spacer .....	2
36703-849	Lockwasher 1/4 .....	2	36703-874	Contact Beam Spring Assy. ....	1
36703-850	Plain Washer .....	2	36703-875	Screw, Socket hd., cap, 10-32 x 5/8 .....	1
36703-851	Plate .....	1	36703-876	Split Lockwasher # 10 .....	1
36703-852	Rotary Servo Housing .....	1	36703-877	Washer, ID .203, OD .438 x .032 .....	1
36703-853	Screw, socket hd., cap 8-32 x 1/2 .....	2	36703-878	Packing .....	1
36703-854	Washer, ID .172 x OD .281 x .047 .....	2	36703-879	Wire Assembly .....	1
36703-855	Dowel Pin .....	2	36703-880	Screw, Ph. Pan Hd., 8-32 x 1/4 .....	1
36703-856	Rotary Servo Vane .....	2	36703-881	Lockwasher Int. Tooth #8 .....	1
36703-857	Vane Load Spring .....	2	36703-882	Terminal Block .....	1
36703-858	Vane Insert .....	2	36703-883	Screw, Ph. Pan Hd. 8-32 x 5/8 .....	2
36703-859	Rotary Servo Shaft .....	1	36703-884	Lockwasher Int Tooth # 8 .....	2
36703-860	Back Plate .....	1	36703-885	Cable Clamp .....	1
36703-861	Dowel Pin .....	2	36703-886	Cover Gasket .....	1
36703-862	Plain Washer .265 x .40 x.05 Thick .....	2	36703-887	Cover .....	1
36703-863	Screw, soc. hd., (self locking ) 1/4-28 x 1/2 .....	2	36703-888	Screw, Socket Hd. Cap 1/4-20 x 1/2 .....	4
36703-864	Gasket .....	1	36703-889	Lockwasher, Hi Collar 1/4 .....	4
36703-865	Side Plate .....	1	36703-890	through 940 Not used	

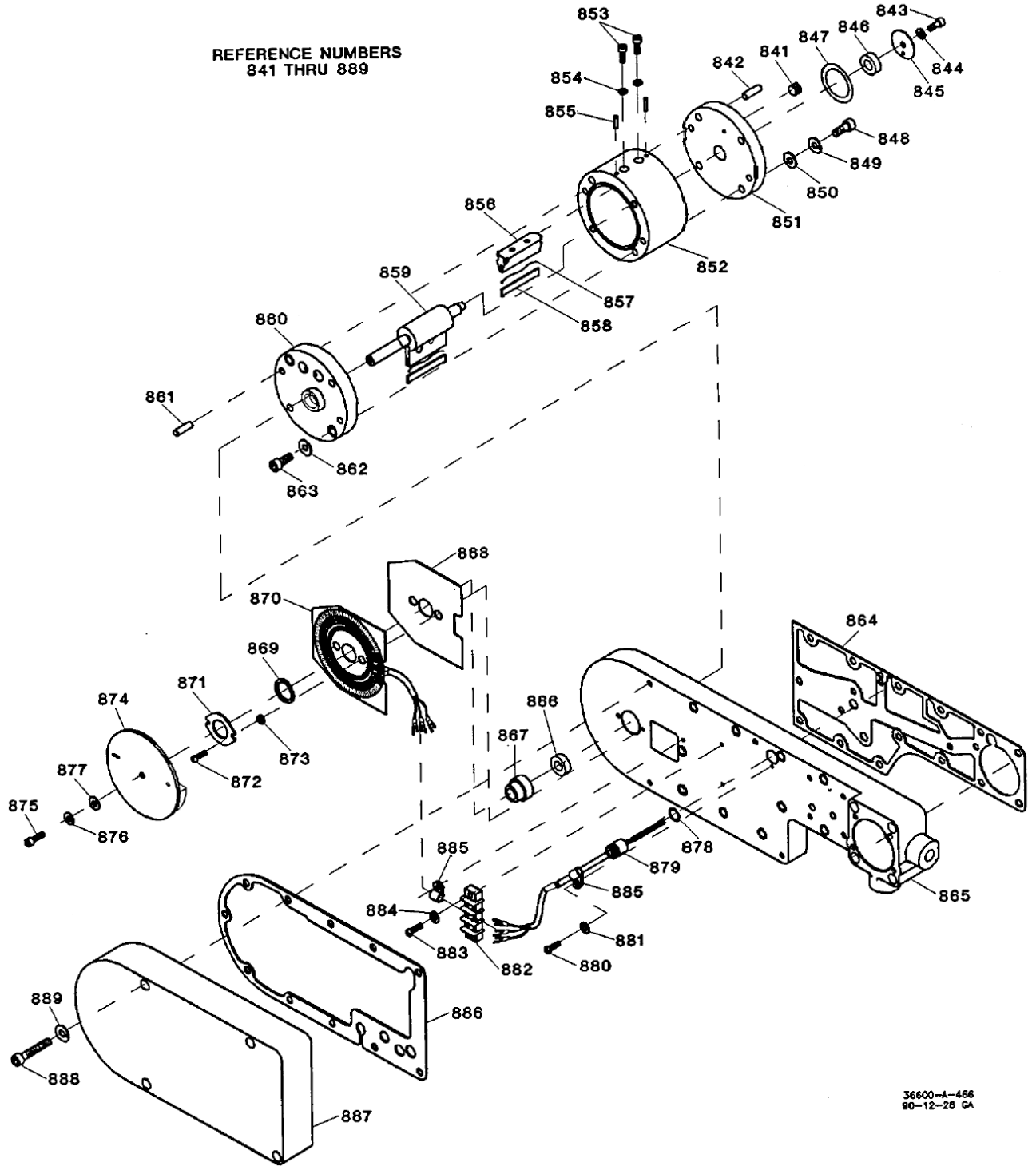

36600-A-456  
90-12-28 GA

Figure 7-12. Exploded View of Vane Servo (Ceramic Resistor)

**Parts List For Figure 7-13**

Ref. No.	Part Name .....	Quantity	Ref. No.	Part Name .....	Quantity
36703-941	Speeder Spring Cylinder .....	2	36703-970	Not Used	
36703-942	Lower Floating Lever .....	2	36703-971	Floating Lever Assy. ....	1
36703-943	Drilled Straight Pin .....	2	36703-972	Spring Lever .....	1
36703-944	Hitch Pin .....	10	36703-973	Nut 10-32 .....	1
36703-945	Speed Droop Fulcrum Pin .....	2	36703-974	Start Fuel Limit Lever .....	1
36703-946	Floating Lever Link .....	2	36703-975	Limit Adj. Screw .....	1
36703-947	Washer ID .203, OD .438 x .032 .....	2	36703-976	Not Used .....	1
36703-948	Link Adj. Spring .....	2	36703-977	Rebalance Rocker Arm .....	7
36703-949	Floating Lever Link .....	2	36703-978	Hitch Pin .....	1
36703-950	Drilled Straight Pin .984 Long .....	1	36703-979	Headed Pin .....	1
36703-951	Plain Washer ID .453, OD .75 x .064 .....	2	36703-980	Stop Block .....	1
36703-952	Adjustable Fulcrum Pin .....	2	36703-981	Spring Washer .....	1
36703-953	Speed Setting Nut .....	2	36703-982	Clamp Bracket .....	1
36703-954	Spacer Washer ID .13025, OD .385 x .120 .....	2	36703-983	Socket Head Cap Screw .....	1
36703-955	Plain Washer ID .203, OD .438, x .032 .....	3	36703-984	Pin .....	1
36703-956	Power Piston Fulcrum Block .....	1	36703-985	Headed Pin .....	1
36703-957	Not Used .....		36703-986	Headed Pin .....	1
36703-958	Speed Setting Lever .....	2	36703-987	Pivot Pin Link .....	1
36703-959	Headed Pin .....	4	36703-988	Pivot Valve Link .....	1
36703-960	Pivot Pin Link .....	2	36703-989	Straight Pin .....	1
36703-961	Floating Lever Assy. ....	1	36703-990	Straight Pin .....	1
36703-962	Hex Nut 10-32 .....	2	36703-991	Pilot Valve Strap .....	2
36703-963	Speed Setting Stop Screw (Oval Point) 10-32 x 1 .....	2	36703-992	Eccentric .....	1
36703-964	Speed Indicator Scale .....	2	36703-993	Adjusting Block .....	1
36703-965	Hex Hd. Machine Screw 10-32 x 3/8 .....	2	36703-994	Socket Head Cap Screw .....	1
36703-966	Washer ID .203, OD .438 x .064 .....	2	36703-995	Washer .....	2
36703-967	Speed Setting Piston .....	2	36703-996	Cotter Pin, Stainless Steel .....	2
36703-968	Drilled Straight Pin 1-5/32 Long .....	1	36703-997	Drilled Pin .....	1
36703-969	Fulcrum Block .....	1	36703-998 through 1000	Not Used	



Parts List For Figure 7-14

Ref. No.	Part Name	Quantity	Ref. No.	Part Name	Quantity
36703-1001	Sensor piston sleeve	1	36703-1033	Orifice case	1
36703-1002	Sensor piston	1	36703-1034	Washer, ID 3/16, OD 3/8, (max.) x 1/16	2
36703-1003	Screw, button soc. hd., Nylok, 8-32 x 3/8	1	36703-1035	Gasket	33
36703-1004	Roll pin, 1/8 x 3/8	1	36703-1036	Orifice plate	32
36703-1005	Fuel limit cam	1	36703-1037	Orifice pack spring	1
36703-1006	Spring seat	1	36703-1038	Washer, ID 9/64, OD 3/8, (max.) x 1/32	1
36703-1007	Restoring spring	1	36703-1039	Retaining ring, internal	1
36703-1008	Restoring spring seat	1	36703-1040	Check valve assy.	1
36703-1009	Bleed valve diaphragm	1	36703-1041	O-ring, OD 1/2	1
36703-1010	Pin, .059 x .082 dia. x 0.782, overall length	1	36703-1042	Filter screen	1
36703-1011	Valve seat	1	36703-1043	O-ring, 1/2 OD	1
36703-1012	Retaining ring, internal (used with item 1016 only)	1	36703-1044	Cotter pin 1/16 x 3/8	1
36703-1013	Bellows output strap	1	36703-1045	Cotter pin 1/16 x 3/8	1
36703-1014	Bellows spacer (used with item 1016 only)	1	36703-1046	Bellcrank	1
36703-1015	O-ring, 1-1/4 OD	1	36703-1047	Straight pin, drilled	1
36703-1016	Sensor bellows (absolute pressure type)	1	36703-1048	Cotter pin, 1/16 x 5/8	1
36703-1017	Ferrule, 1/4 tube	1	36703-1049	Needle bearing	1
36703-1018	Lockwasher, #10	1	36703-1050	Fuel limit floating lever	1
36703-1019	Screw, soc. hd., 10-32 x 1-1/2	1	36703-1051	Pivot	1
36703-1020	Screw, hex. hd., 1/4-28 x 3/4	1	36703-1052	Fuel limit lever	1
36703-1021	Washer, soft copper	1	36703-1053	Loading spring	1
36703-1022	Eccentric	1	36703-1054	Cotter pin, 1/16 x 5/8	1
36703-1023	Gasket, copper	1	36703-1055	Retaining ring, E-type	1
36703-1024	Steel ball	1	36703-1056	Adjusting screw, fuel limit	1
36703-1025	Screw, button, soc. hd., Nylok, 8-32 x 3/8	2	36703-1057	Feedback lever	1
36703-1026	O-ring, 0.375 OD	1	36703-1058	Pivot pin (fuel limit lever)	1
36703-1027	Cylinder head	1	36703-1059	Linkage bracket	1
36703-1028	Lockwasher, 1/4	1	36703-1060	Screw, soc. hd., 10-32 x 1/2	2
36703-1029	Screw, soc. hd., 1/4-28 x 1-3/4	1	36703-1061	Lockwasher, #10	2
36703-1030	Lockwasher, 1/4	1	36703-1062	Amplifier piston	1
36703-1031	Screw, soc. hd., 1/4-28 x 1-1/8	1	36703-1063	Pivot pin (bellcrank)	1
36703-1032	Not Used		36703-1064	Amplifier pilot valve plunger	1
			36703-1065	Pilot valve loading spring	1
			36703-1066	Housing	1
			36703-1067	Through 1080 Not Used	

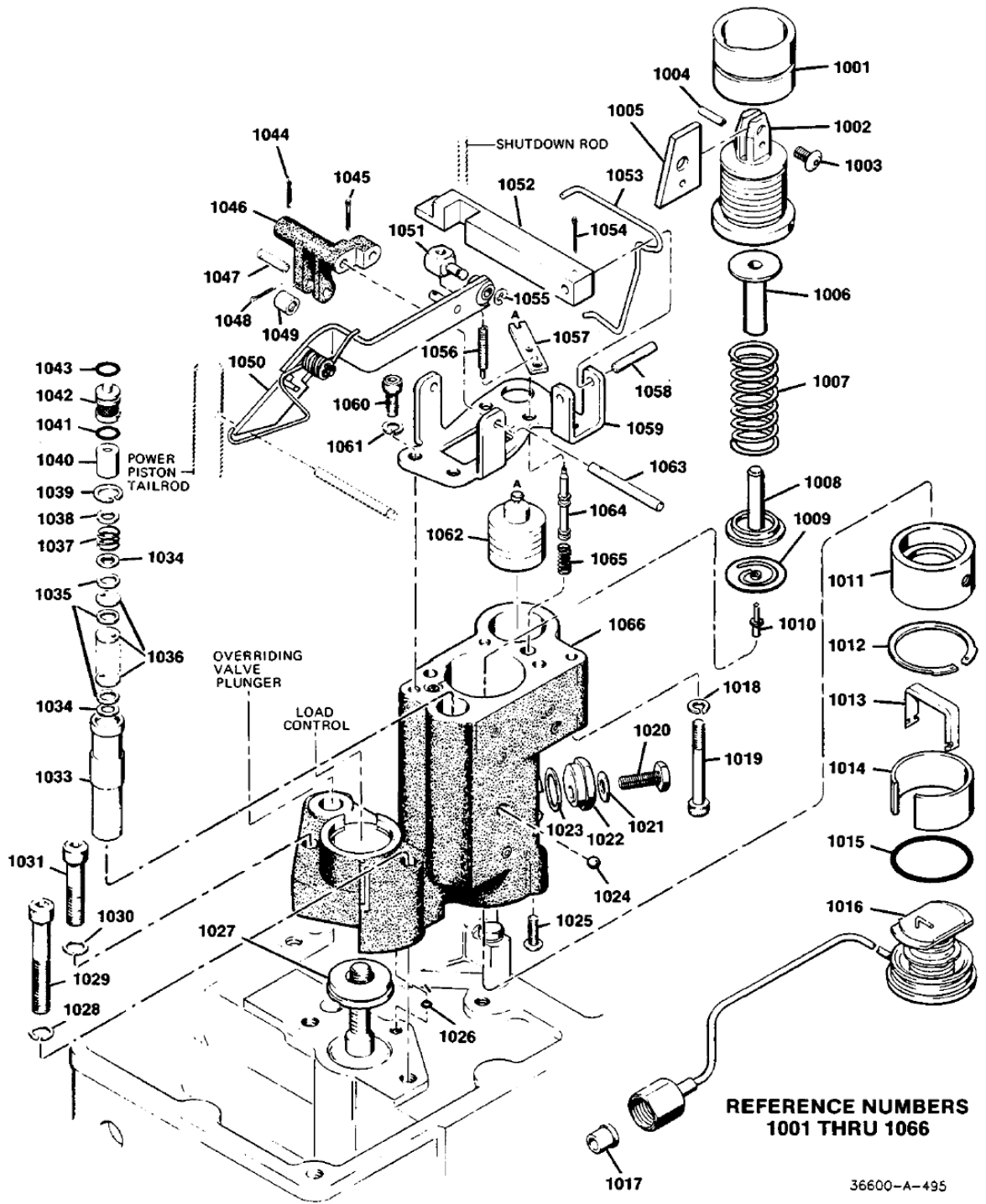

36600-A-495

Figure 7-14. Exploded View of Fuel Limiter

Parts List For Figure 7-15

Ref. No.	Part Name.....	Quantity
36703-1081	Plug and filter assy. ....	1
36703-1082	Preformed packing, ID 1.049 x .103 .....	1
36703-1083	Preformed packing, ID .674 x .103 .....	1
36703-1084	Preformed packing, ID 1.051 x .070 .....	1
36703-1085	Preformed packing, ID .301 x .070 .....	1
36703-1086	Screw, soc. hd., 1/4-28 x 2-3/4 .....	4
36703-1087	Lockwasher, Split, 1/4 .....	4
36703-1088	Oil Filter Case.....	1
36703-1089	through 1100 .....	Not Used

REFERENCE NUMBERS  
1081 THRU 1088

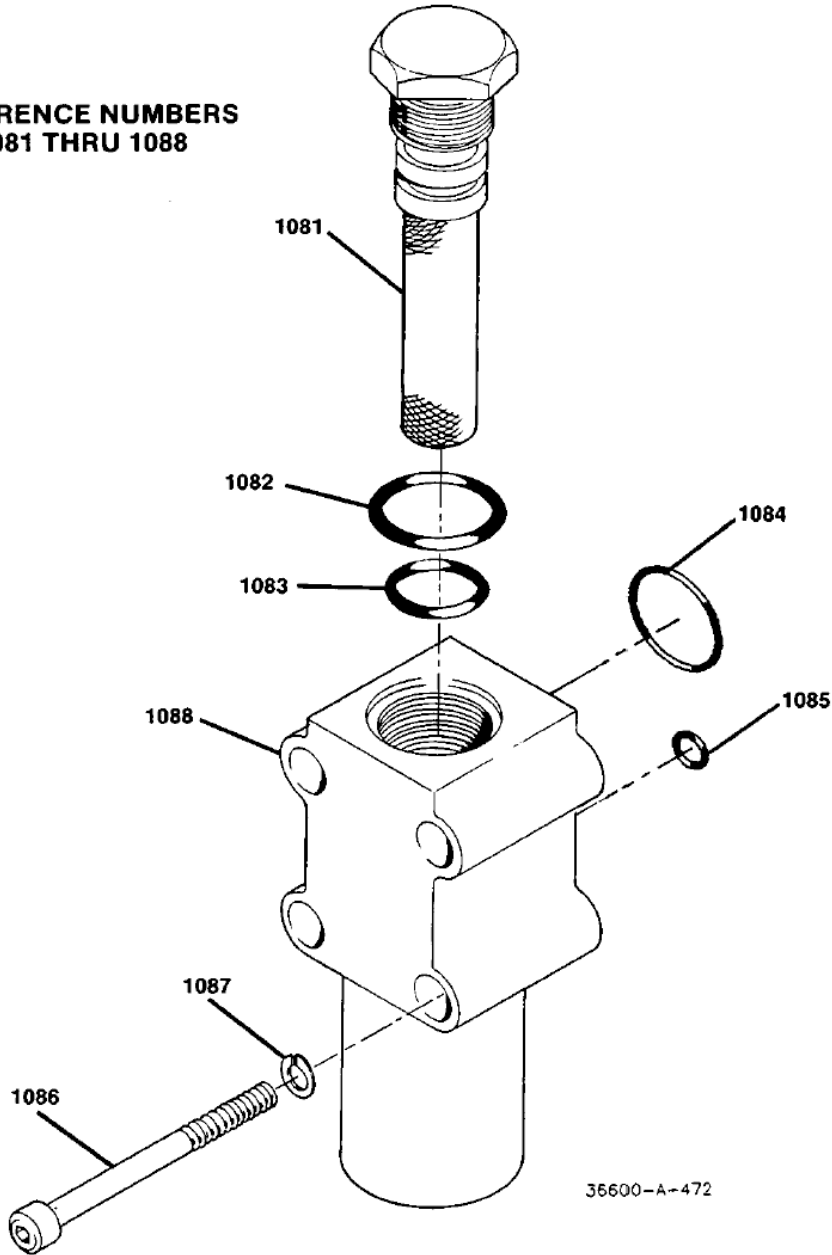

Figure 7-15. Exploded View of Oil Filter

[This page intentionally left blank]

**Parts List For Figure 7-16**

<b>Ref. No.</b>	<b>Part Name</b> .....	<b>Quantity</b>	<b>Ref. No.</b>	<b>Part Name</b> .....	<b>Quantity</b>
36703-1101	Nut, 3/4-32 .....	5	36703-1122	Jam nuts (Lube oil signal switch) .....	1
36703-1102	Solenoid plunger stop.....	5	36703-1123	Switch mounting bracket.....	1
36703-1103	Solenoid case.....	5	36703-1124	Switch bracket clamp plate .....	1
36703-1104	Solenoid load spring.....	5	36703-1125	Connector plate (used with item 1134)....	1
36703-1105	Paper insulator .....	5	36703-1126	Electrical connector (Amphenol) .....	1
36703-1106	Solenoid coil.....	5	36703-1127	Screw, fil. 6-32 x 3/8 .....	4
36703-1107	Solenoid plunger .....	5	36703-1128	Connector plate gasket (sq. hole) .....	1
36703-1108	Snap ring.....	5	36703-1129	Lockwasher, int. tooth, #6.....	4
36703-1109	Solenoid plunger pushrod .....	5	36703-1130	Screw, flat hd., 10-32 x 3/8 .....	4
36703-1110	Washer, Beryllium copper .....	5	36703-1131	Connector plate (used with item 1134)....	1
36703-1111	Insulator bushing (Teflon).....	10	36703-1132	Screw, flat hd., 10-32 x 3/8 .....	4
36703-1112	Solenoid guide .....	5	36703-1133	Connector plate gasket (rd. hole).....	1
36703-1113	Guide bushing; press fit.....	10	36703-1134	Electrical connector (Pyle National) .....	1
36703-1114	Screw, rd. hd., 8 x 1-1/4, type 2.....	3	36703-1135	Soldering Shield Washer.....	10
36703-1115	Plain washer, 13/16, 7/16 x 1/32 .....	3	36703-1136	Solenoid Plunger Assy. ....	5
36703-1116	Screw, soc., hd., 10-32 x 2-1/4.....	2	36703-1137	Snap Ring .....	5
36703-1117	Washer, splitlock, #10 .....	2	36703-1138	Insulator bushing, (Teflon) .....	10
36703-1118	Solenoid bracket .....	1	36703-1139	Guide bushing, press fit .....	5
36703-1119	Setscrew, soc. hd., cup pt., 10-32 x 1/4 ...	5	36703-1140	Lube Oil Signal Switch .....	1
36703-1120	Speed nut, #11, type J .....	3	36703-1141	Solenoid guide .....	1
36703-1121	Wiring shield.....	1	36703-1142 through 1150	Not Used	

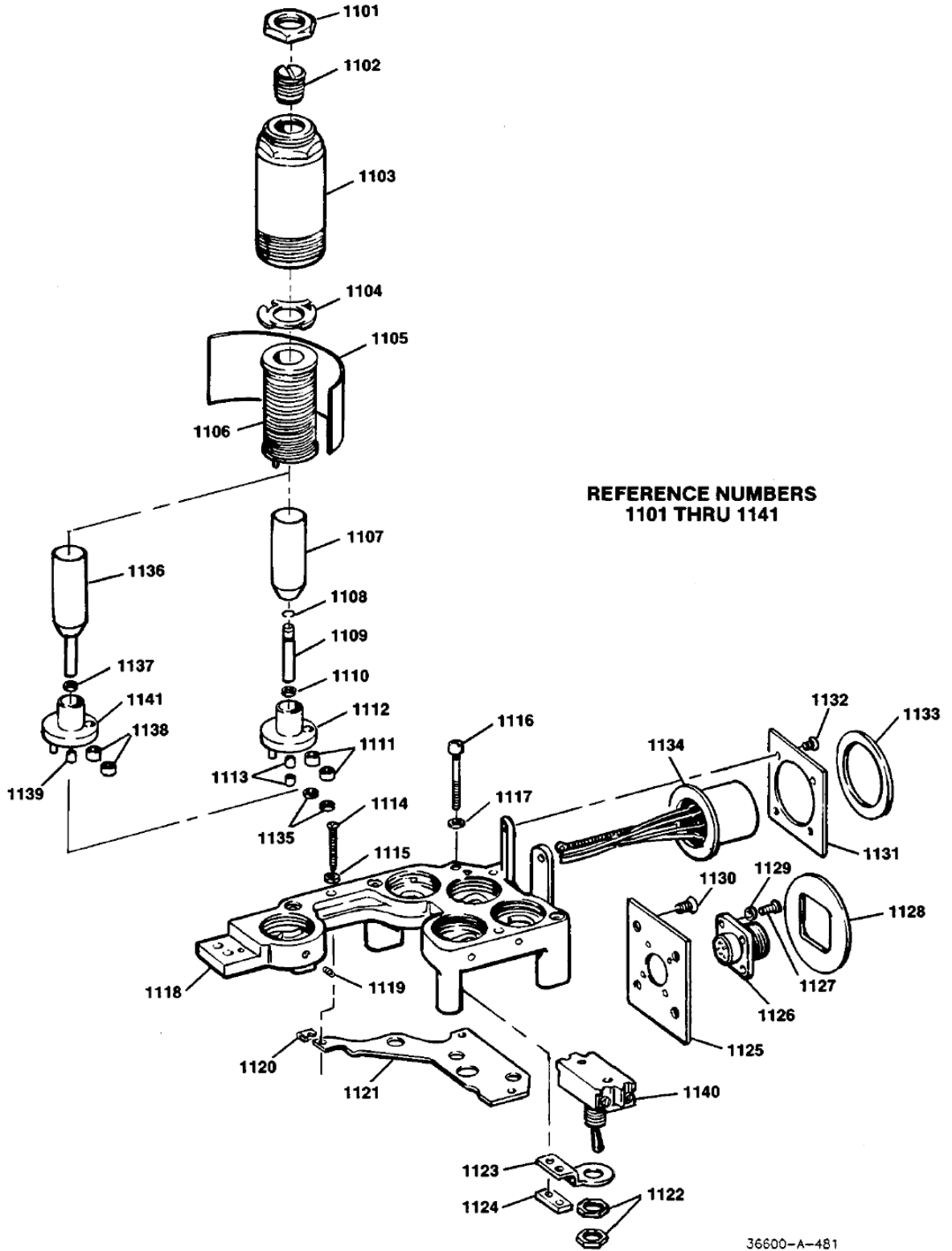

Figure 7-16. Exploded View of Electrical Receiver Assembly

## Parts List For Figure 7-17

Ref. No.	Part Name .....	Quantity	Ref. No.	Part Name .....	Quantity
36703-1151	Stainless Steel Tubing Assy.....	1	36703-1181	Failure Plunger.....	1
36703-1152	Stainless Steel Tubing Assy.....	1	36703-1182	Diaphragm .....	1
36703-1153	Screw, Soc. Hd. Cap, 1/4 20 x 3.00 (SST)2		36703-1183	Diaphragm Washer .....	1
36703-1154	Split Lockwasher, ID 1/4, OD .365 max., x 078 .....	2	36703-1184	Plunger End .....	1
36703-1155	Screw Soc., Cap, 10-32 x 7/8 .....	2	36703-1185	Straight Pin for Plunger End.....	1
36703-1156	Split Lockwasher #10 .....	2	36703-1186	Needle Bearing .....	2
36703-1157	Switch Cover .....	1	36703-1187	Diaphragm Plate .....	1
36703-1158	Preformed Packing ID 2.55 x .103.....	1	36703-1188	Screw, fil. hd., 1/4-20 x 3/4.....	4
36703-1159	Toggle Switch/Plate Mounting Nut .....	1	36703-1189	Lock washer, split, ID 1/4, OD. 365 Max., x .078 .....	4
36703-1160	Switch Mounting Plate.....	1	36703-1190	Ratio Lever.....	1
36703-1161	Screw, Soc., Hd., Cap, 6-32 x 3/8 .....	2	36703-1191	Plain Washer #8.....	2
36703-1162	Split Lockwasher #6 .....	2	36703-1192	Ratio Lever Block.....	1
36703-1163	Plain washer ID .141, OD .37, x .031 .....	1	36703-1193	Straight Pin .....	1
36703-1164	Water Shutdown Case Assy.....	1	36703-1194	Strap Clamp .....	2
36703-1165	Sleeve .....	1	36703-1195	Screw, Hex Hd., 1/4-28 x 1-1/8 .....	4
36703-1166	Buffer Spring .....	1	36703-1196	Split Lockwasher 1/4 .....	4
36703-1167	Preformed Packing, .364 ID x .070 .....	1	36703-1197	Water Box Diaphragm.....	1
36703-1168	Wiring Tube.....	1	36703-1198	Water Box Diaphragm Washer .....	1
36703-1169	Preformed Packing ID .364 x .070.....	1	36703-1199	Nut, Lock 10-32.....	1
36703-1170	Wires .....	AR	36703-1200	Load Spring.....	1
36703-1171	Preformed Packing ID .364 x .070.....	1	36703-1201	Load Spring Retainer .....	1
36703-1172	Not Used .....	1	36703-1202	Adjustment Screw .....	1
36703-1173	Not Used .....	1	36703-1203	Roll Pin 1/16 x 7/16 .....	1
36703-1174	Shutdown Plunger .....	1	36703-1204	Preformed Packing 3/8 OD .....	1
36703-1175	Failure Piston Spring .....	1	36703-1205	Water Box .....	1
36703-1176	Failure Piston .....	1	36703-1206	Screw, Soc. Hd. Cap, 10-32 x 5/8.....	4
36703-1177	Bushing Gasket.....	1	36703-1207	Split Lockwasher #10 .....	4
36703-1178	Retainer plate (bushing assy.).....	1	36703-1208	Nut, Hex Drilled 1/4-28.....	1
36703-1179	Plain Washer, ID .25, OD .485, x .031 .....	1	36703-1209	Plain washer ID 11/64, x OD 1/2, x .064 ..	1
36703-1180	Screw, Soc. Hd., Cap, 1/4-28 x 3/8 .....	1			

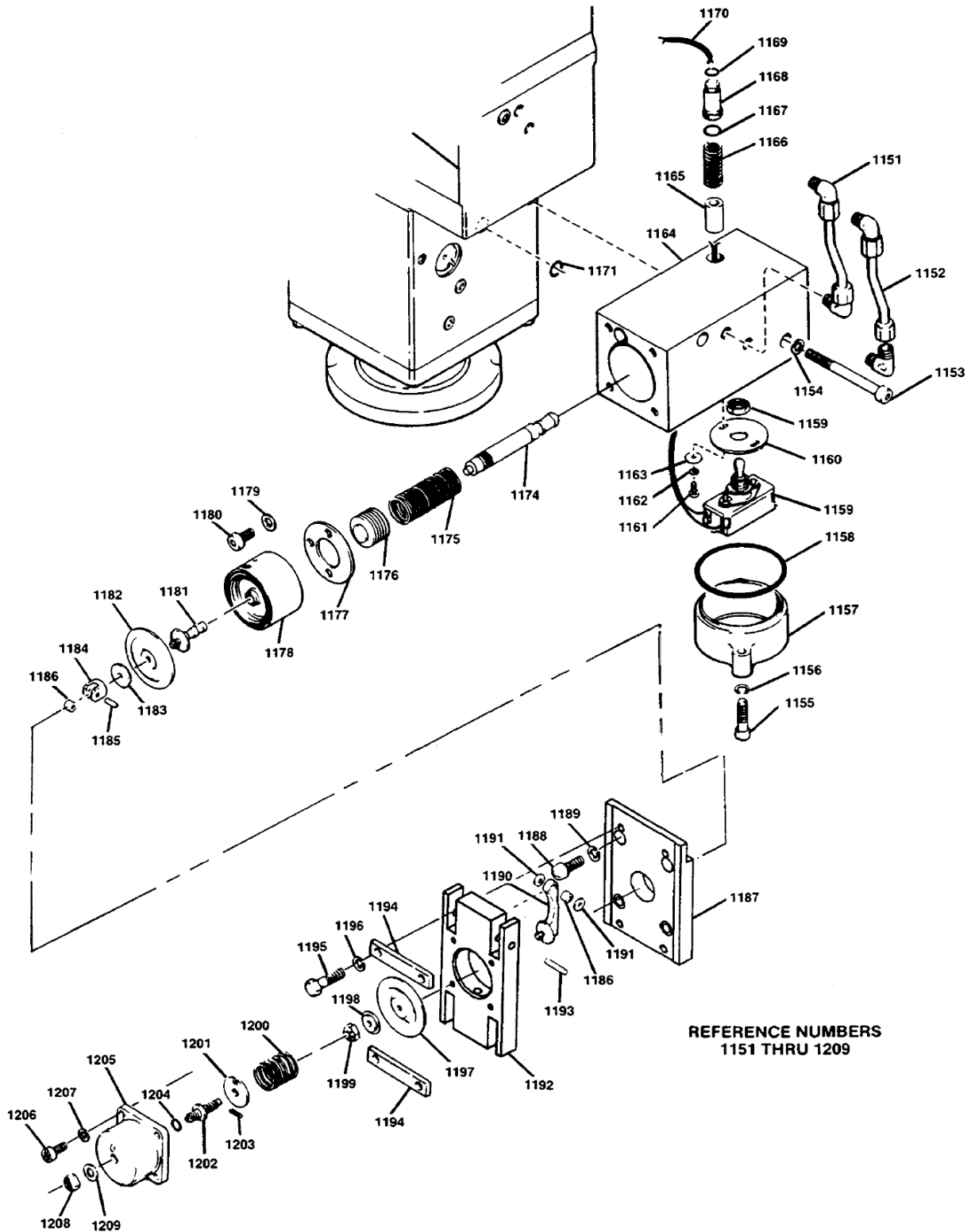

Figure 7-17. Exploded View of Water Box

# Chapter 8.

## Service Options

### Product Service Options

The following factory options are available for servicing Woodward equipment, based on the standard Woodward Product and Service Warranty (5-01-1205) that is in effect at the time the product is purchased from Woodward or the service is performed:

- Replacement/Exchange (24-hour service)
- Flat Rate Repair
- Flat Rate Remanufacture

If you are experiencing problems with installation or unsatisfactory performance of an installed system, the following options are available:

- Consult the troubleshooting guide in the manual.
- Contact Woodward technical assistance (see “How to Contact Woodward” later in this chapter) and discuss your problem. In most cases, your problem can be resolved over the phone. If not, you can select which course of action you wish to pursue based on the available services listed in this section.

### Replacement/Exchange

Replacement/Exchange is a premium program designed for the user who is in need of immediate service. It allows you to request and receive a like-new replacement unit in minimum time (usually within 24 hours of the request), providing a suitable unit is available at the time of the request, thereby minimizing costly downtime. This is also a flat rate structured program and includes the full standard Woodward product warranty (Woodward Product and Service Warranty 5-01-1205).

This option allows you to call in the event of an unexpected outage, or in advance of a scheduled outage, to request a replacement control unit. If the unit is available at the time of the call, it can usually be shipped out within 24 hours. You replace your field control unit with the like-new replacement and return the field unit to the Woodward facility as explained below (see “Returning Equipment for Repair” later in this chapter).

Charges for the Replacement/Exchange service are based on a flat rate plus shipping expenses. You are invoiced the flat rate replacement/exchange charge plus a core charge at the time the replacement unit is shipped. If the core (field unit) is returned to Woodward within 60 days, Woodward will issue a credit for the core charge. [The core charge is the average difference between the flat rate replacement/exchange charge and the current list price of a new unit.]

**Return Shipment Authorization Label.** To ensure prompt receipt of the core, and avoid additional charges, the package must be properly marked. A return authorization label is included with every Replacement/Exchange unit that leaves Woodward. The core should be repackaged and the return authorization label affixed to the outside of the package. Without the authorization label, receipt of the returned core could be delayed and cause additional charges to be applied.

## Flat Rate Repair

Flat Rate Repair is available for the majority of standard products in the field. This program offers you repair service for your products with the advantage of knowing in advance what the cost will be. All repair work carries the standard Woodward service warranty (Woodward Product and Service Warranty 5-01-1205) on replaced parts and labor.

## Flat Rate Remanufacture

Flat Rate Remanufacture is very similar to the Flat Rate Repair option with the exception that the unit will be returned to you in “like-new” condition and carry with it the full standard Woodward product warranty (Woodward Product and Service Warranty 5-01-1205). This option is applicable to mechanical products only.

## Returning Equipment for Repair

If a control (or any part of an electronic control) is to be returned to Woodward for repair, please contact Woodward in advance to obtain a Return Authorization Number. When shipping the item(s), attach a tag with the following information:

- name and location where the control is installed;
- name and phone number of contact person;
- complete Woodward part number(s) and serial number(s);
- description of the problem;
- instructions describing the desired type of repair.



### **CAUTION—ELECTROSTATIC DISCHARGE**

To prevent damage to electronic components caused by improper handling, read and observe the precautions in Woodward manual 82715, *Guide for Handling and Protection of Electronic Controls, Printed Circuit Boards, and Modules*.

## Packing a Control

Use the following materials when returning a complete control:

- protective caps on any connectors;
- antistatic protective bags on all electronic modules;
- packing materials that will not damage the surface of the unit;
- at least 100 mm (4 inches) of tightly packed, industry-approved packing material;
- a packing carton with double walls;
- a strong tape around the outside of the carton for increased strength.

## Return Authorization Number

When returning equipment to Woodward, please telephone and ask for the Customer Service Department [1 (800) 523-2831 in North America or +1 (970) 482-5811]. They will help expedite the processing of your order through our distributors or local service facility. To expedite the repair process, contact Woodward in advance to obtain a Return Authorization Number, and arrange for issue of a purchase order for the item(s) to be repaired. No work can be started until a purchase order is received.



### NOTE

**We highly recommend that you make arrangement in advance for return shipments. Contact a Woodward customer service representative at 1 (800) 523-2831 in North America or +1 (970) 482-5811 for instructions and for a Return Authorization Number.**

## Replacement Parts

When ordering replacement parts for controls, include the following information:

- the part number(s) (XXXX-XXXX) that is on the enclosure nameplate;
- the unit serial number, which is also on the nameplate.

## How to Contact Woodward

In North America use the following address when shipping or corresponding:

Woodward Governor Company  
PO Box 1519  
1000 East Drake Rd  
Fort Collins CO 80522-1519, USA

Telephone—+1 (970) 482-5811 (24 hours a day)  
Toll-free Phone (in North America)—1 (800) 523-2831  
Fax—+1 (970) 498-3058

For assistance outside North America, call one of the following international Woodward facilities to obtain the address and phone number of the facility nearest your location where you will be able to get information and service.

<u>Facility</u>	<u>Phone Number</u>
Brazil	+55 (19) 3708 4800
India	+91 (129) 230 7111
Japan	+81 (476) 93-4661
The Netherlands	+31 (23) 5661111

You can also contact the Woodward Customer Service Department or consult our worldwide directory on Woodward's website ([www.woodward.com](http://www.woodward.com)) for the name of your nearest Woodward distributor or service facility.

## Engineering Services

Woodward Industrial Controls Engineering Services offers the following after-sales support for Woodward products. For these services, you can contact us by telephone, by email, or through the Woodward website.

- Technical Support
- Product Training
- Field Service

Contact information:

Telephone—+1 (970) 482-5811

Toll-free Phone (in North America)—1 (800) 523-2831

Email—[icinfo@woodward.com](mailto:icinfo@woodward.com)

Website—[www.woodward.com](http://www.woodward.com)

**Technical Support** is available through our many worldwide locations or our authorized distributors, depending upon the product. This service can assist you with technical questions or problem solving during normal business hours. Emergency assistance is also available during non-business hours by phoning our toll-free number and stating the urgency of your problem. For technical support, please contact us via telephone, email us, or use our website and reference **Customer Services** and then **Technical Support**.

**Product Training** is available at many of our worldwide locations (standard classes). We also offer customized classes, which can be tailored to your needs and can be held at one of our locations or at your site. This training, conducted by experienced personnel, will assure that you will be able to maintain system reliability and availability. For information concerning training, please contact us via telephone, email us, or use our website and reference **Customer Services** and then **Product Training**.

**Field Service** engineering on-site support is available, depending on the product and location, from one of our many worldwide locations or from one of our authorized distributors. The field engineers are experienced both on Woodward products as well as on much of the non-Woodward equipment with which our products interface. For field service engineering assistance, please contact us via telephone, email us, or use our website and reference **Customer Services** and then **Technical Support**.

### Technical Assistance

If you need to telephone for technical assistance, you will need to provide the following information. Please write it down here before phoning:

#### General

Your Name \_\_\_\_\_  
Site Location \_\_\_\_\_  
Phone Number \_\_\_\_\_  
Fax Number \_\_\_\_\_

#### Prime Mover Information

Engine/Turbine Model Number \_\_\_\_\_  
Manufacturer \_\_\_\_\_  
Number of Cylinders (if applicable) \_\_\_\_\_  
Type of Fuel (gas, gaseous, steam, etc) \_\_\_\_\_  
Rating \_\_\_\_\_  
Application \_\_\_\_\_

#### Control/Governor Information

Please list all Woodward governors, actuators, and electronic controls in your system:

Woodward Part Number and Revision Letter \_\_\_\_\_  
Control Description or Governor Type \_\_\_\_\_  
Serial Number \_\_\_\_\_

Woodward Part Number and Revision Letter \_\_\_\_\_  
Control Description or Governor Type \_\_\_\_\_  
Serial Number \_\_\_\_\_

Woodward Part Number and Revision Letter \_\_\_\_\_  
Control Description or Governor Type \_\_\_\_\_  
Serial Number \_\_\_\_\_

*If you have an electronic or programmable control, please have the adjustment setting positions or the menu settings written down and with you at the time of the call.*

## Appendix.

# Auxiliary Equipment

### Automatic Safety Shutdown and Alarms (Manual 36652)

A "Lube Oil Pressure Failure Shutdown and Alarm Device" (Figure 1-2 or 1-3) protects the engine in the event of the loss of normal lube oil operating pressure. It monitors lubricating-oil pressure and is so designed that the shutdown pressure level becomes progressively higher as engine speed increases.

A second device, a "Lube Oil Pressure Failure With Excessive Vacuum Shutdown and Alarm", has the added feature of monitoring the inlet side of the engine oil pump. Excessive vacuum will trigger the shutdown and alarm system.

A time-delay feature (see Figure 1-2) allows the engine to be started without lubricating-oil pressure yet prevents prolonged operation if a safe pressure level is not reached within the preset time.

A "Cooling Water Pressure Failure Shutdown" device (Figure 1-3) protects the engine from a drop in the normal operating pressure of the water cooling system. A time-delay and bypass feature is common to the system when the oil and water shutdown devices are used together.

### Load Control Override (Manual 36695)

This mechanism overrides the normal functioning of the load-control system reducing generator field excitation current during engine startup, wheel slip, or transition.

### Manifold Air Pressure Bias Fuel Limiter (Manuals 36601 and 36695)

The fuel limiter acts to restrict engine fuel during acceleration as a function of manifold air pressure to ensure more complete combustion, reducing smoke to a minimum and improving acceleration. Two models of this device are available, a two-barrel model (manual 36601) or a single-barrel (inline) model (manual 36695). While physically dissimilar in appearance and installation, they are essentially identical in function and achieve the same end result. Parts information for the oil filter used in conjunction with either model fuel limiter is found in Figure 7-16).

Two variations of bias linkages are available for use in conjunction with either model fuel limiter as described above and are covered in detail in the applicable fuel limiter manual.

### Overspeed Valve

This is a backup safety mechanism used in conjunction with a separate overspeed-shutdown trip. It monitors the tripping oil-supply pressure and causes engine shutdown in the event the tripping oil pressure drops below a safe level. See Figure 3-1 for a schematic representation of the valve.





We appreciate your comments about the content of our publications.

Send comments to: [icinfo@woodward.com](mailto:icinfo@woodward.com)

Please include the manual number from the front cover of this publication.



PO Box 1519, Fort Collins CO 80522-1519, USA  
1000 East Drake Road, Fort Collins CO 80525, USA  
Phone +1 (970) 482-5811 • Fax +1 (970) 498-3058

Email and Website—[www.woodward.com](http://www.woodward.com)

Woodward has company-owned plants, subsidiaries, and branches,  
as well as authorized distributors and other authorized service and sales facilities throughout the world.

Complete address / phone / fax / email information for all locations is available on our website.